

# Reference Manual



## B57 ENGINE



## Technical Training

The information contained in this manual is not to be resold, bartered, copied or transferred without the express written consent of BMW of North America, LLC ("BMW NA").

**Technical training.**  
Product information.

## **B57 Engine**



**BMW Service**

Edited for the U.S. market by:  
**BMW Group University**  
Technical Training

ST1704

10/1/2018

# General information

## Symbols used

The following symbol is used in this document to facilitate better comprehension or to draw attention to very important information:



---

Contains important safety information and information that needs to be observed strictly in order to guarantee the smooth operation of the system.

---

## Information status and national-market versions

BMW Group vehicles meet the requirements of the highest safety and quality standards. Changes in requirements for environmental protection, customer benefits and design render necessary continuous development of systems and components. Consequently, there may be discrepancies between the contents of this document and the vehicles available in the training course.

This document basically relates to the European version of left hand drive vehicles. Some operating elements or components are arranged differently in right-hand drive vehicles than shown in the graphics in this document. Further differences may arise as the result of the equipment specification in specific markets or countries.

## Additional sources of information

Further information on the individual topics can be found in the following:

- Owner's Handbook
- Integrated Service Technical Application.

Contact: [conceptinfo@bmw.de](mailto:conceptinfo@bmw.de)

©2015 BMW AG, Munich

## Reprints of this publication or its parts require the written approval of BMW AG, Munich.

The information contained in this document forms an integral part of the technical training of the BMW Group and is intended for the trainer and participants in the seminar. Refer to the latest relevant information systems of the BMW Group for any changes/additions to the technical data.

Information status: **June 2015**  
**Technical training.**

# B57 Engine

## Contents

<b>1. History</b>	<b>1</b>
1.1. N57 Engines	1
<b>2. Introduction</b>	<b>2</b>
2.1. Engine identification	2
2.1.1. Engine designation	2
2.1.2. Engine identification	3
2.2. Technical data	4
2.2.1. Performance diagram	5
2.3. Model	6
2.4. Innovations	6
2.5. Modular design	7
<b>3. Engine Mechanical</b>	<b>8</b>
3.1. Engine housing	8
3.1.1. Cylinder head cover	9
3.1.2. Cylinder head	10
3.1.3. Cylinder head gasket	11
3.1.4. Engine block	12
3.1.5. Oil sump	16
3.2. Crankshaft drive	17
3.2.1. Crankshaft	17
3.2.2. Connecting rod	19
3.2.3. Piston	21
3.3. Chain drive	22
3.3.1. Camshaft sprocket of the high pressure pump	24
3.3.2. Timing chain	24
3.4. Valve gear	25
3.4.1. Timing	25
3.4.2. Camshaft	26
3.5. Belt drive	28
3.5.1. Torsional vibration damper	29
3.6. Sound insulation	31
3.6.1. Thermo-acoustic capsule (SynTAK)	32
<b>4. Oil Supply</b>	<b>34</b>
4.1. Oil circuit	34
4.2. Characteristic map-controlled oil supply	36
4.2.1. Map control valve	37
4.3. Oil pump	38
4.3.1. Vane-type compressor oil pump	38

# B57 Engine

## Contents

4.4.	Piston cooling.....	40
4.4.1.	Central valve.....	44
4.4.2.	Oil spray nozzles.....	48
4.4.3.	Oil pressure switch.....	49
4.4.4.	Switching strategy.....	49
4.5.	Oil filter module.....	50
4.5.1.	Discharge valve.....	51
<b>5.</b>	<b>Cooling System.....</b>	<b>52</b>
5.1.	Cooling circuit.....	52
5.1.1.	System overview.....	52
5.1.2.	Cooling module.....	53
5.2.	Coolant pump.....	54
5.2.1.	Shift element open.....	56
5.2.2.	Shift element closed, warm-up function.....	57
5.3.	Coolant thermostat.....	59
5.3.1.	Primary coolant thermostat.....	59
5.3.2.	Secondary coolant thermostat.....	61
5.4.	Transmission oil cooling.....	62
5.5.	Coolant.....	62
5.5.1.	Cooling system bleeding.....	63
<b>6.</b>	<b>Intake Air and Exhaust System.....</b>	<b>65</b>
6.1.	System overview.....	65
6.1.1.	B57D3000.....	65
6.2.	Intake air system.....	67
6.2.1.	Air duct overview.....	67
6.2.2.	Charge air cooler.....	69
6.2.3.	Throttle valve.....	69
6.3.	Exhaust turbocharger.....	70
6.3.1.	Charging pressure control.....	70
6.3.2.	Exhaust turbochargers B57D3000.....	71
6.4.	Exhaust re-treatment.....	72
6.5.	Exhaust-gas recirculation.....	74
6.5.1.	High-pressure exhaust-gas recirculation.....	80
6.5.2.	Low-pressure exhaust-gas recirculation.....	82
6.5.3.	Exhaust gas restriction flap.....	85
6.5.4.	Exhaust-gas recirculation control.....	87
<b>7.</b>	<b>Vacuum Supply.....</b>	<b>89</b>
7.1.	System overview.....	89

# B57 Engine

## Contents

7.1.1.	Electric changeover valve.....	90
<b>8.</b>	<b>Fuel System.....</b>	<b>91</b>
8.1.	Fuel supply.....	91
8.2.	Fuel preparation.....	91
8.2.1.	Overview of common rail systems.....	92
8.2.2.	High pressure pump CP 4.2/25.....	93
8.2.3.	CRI 3.25 injectors.....	94
8.2.4.	High pressure rail HFR 25.....	97
8.2.5.	Leakage oil line.....	97
8.2.6.	Rail pressure control.....	97
<b>9.</b>	<b>Engine Electrical System.....</b>	<b>98</b>
9.1.	System wiring diagram.....	98
9.2.	Digital Diesel Electronics.....	102
9.3.	Preheating system.....	103
9.4.	Sensors.....	105
9.4.1.	Oil level sensor.....	105
9.4.2.	Combustion chamber pressure sensor.....	105
9.4.3.	Hot film air mass meter.....	108
9.4.4.	Diesel particulate sensor (only US version).....	111
9.5.	Exhaust emission system.....	115
9.5.1.	High- and low-pressure exhaust-gas recirculation.....	117
9.5.2.	Diesel particulate filter regeneration.....	119
9.5.3.	Diesel particulate filter cleaning.....	123
9.6.	BMW models (US) with SCR technology.....	125
9.6.1.	Installation locations of SCR components (US only).....	126
9.6.2.	Differences in the system technology.....	128
<b>10.</b>	<b>SCR 3.....</b>	<b>129</b>
10.1.	Overview.....	129
10.1.1.	Installation locations.....	131
10.1.2.	System overview in detail .....	133
10.1.3.	System wiring diagram.....	135
10.2.	Functions.....	137
10.2.1.	SCR control.....	137
10.2.2.	Supply of the urea/water mixture (AdBlue®).....	140
10.2.3.	Metering of the urea/water mixture (AdBlue®).....	140
10.2.4.	Warning and switch off scenario.....	155
10.2.5.	On-board diagnosis functions.....	158
10.3.	System components.....	161

# B57 Engine

## Contents

10.3.1.	Passive tank.....	161
10.3.2.	Recirculating pump unit.....	164
10.3.3.	Active tank.....	165
10.3.4.	Tank flange module.....	166
10.3.5.	Heated metering line.....	175
10.3.6.	Metering module and mixer.....	177
10.3.7.	Urea/water mixture (AdBlue®) fluid filler cap.....	179
10.3.8.	SCR control unit .....	180
10.4.	NOx sensors.....	181

# B57 Engine

## 1. History

### 1.1. N57 Engines

Engine	Unit	N57D30T0	
 <p>TD10-1787</p>	Series	US market E90 E70 F10	
	Models	335d, X5, 535d	
	Power output at engine speed	[kW/HP] [rpm]	210/286 4400
	Torque at engine speed	[Nm/lb-ft] [rpm]	580/425 1750
	Design		6 cylinders/in-line
	Displacement	[cm <sup>3</sup> ]	2993
	Bore/stroke	[mm]	84/90
	Compression ratio	[ε]	16.5 : 1
	Valves per cylinder		4
	Deployment period		9/2009 – 9/2011
	Engine control		DDE 7.3

Engine	Unit	N57D3001	
 <p>TD15-0043</p>	Series	US version F02, F10, F15	
	Models	US version 740d, 535d, X5 xDrive35d	
	Power output at engine speed	[kW/HP] [rpm]	190/255 4000
	Torque at engine speed	[Nm/lb-ft] [rpm]	560/413 1500 – 3000
	Design		6 cylinders/in-line
	Displacement	[cm <sup>3</sup> ]	2993
	Bore/stroke	[mm]	84/90
	Compression ratio	[ε]	16.5 : 1
	Valves per cylinder		4
	Deployment period		since 03/2011
	Engine control		DDE 7.41



# B57 Engine

## 2. Introduction

The series introduction of the BMW 5 Series (G30) in 2017 will be expanded to include a diesel model later in the year for the US market. The new US market diesel B57 engine will be introduced in the upper performance class. The B57 engine therefore expands the B engine range. In spite of the higher power and torque, it was possible to further reduce fuel consumption and lower exhaust emissions.

This was made possible by the use of a 3rd-generation common rail system with 2,500 bar fuel injection pressure, a characteristic map-controlled oil pump as well as piston cooling that can be deactivated when not needed. As with previous BMW diesels, the high-pressure exhaust-gas recirculation is supplemented by a low-pressure exhaust-gas recirculation system in order to increase the efficiency of the engine despite reduced NO<sub>x</sub> emissions.

The engines are distinguished as follows in this document:

- B57D3000 = B57 engine in the upper performance class

### 2.1. Engine identification

#### 2.1.1. Engine designation

In the technical documentation, the engine designation is used to ensure clear identification of the engine. Frequently, only a short designation is used, which is explained in the following table.

Position	Meaning	Index	Explanation
1	Engine developer	N, B P S W	BMW Group BMW M Sport BMW M GmbH Third-party engine
2	Engine type	3 4 5	3-cylinder in-line engine 4-cylinder in-line engine 6-cylinder in-line engine
3	Change to the basic engine concept	7	Diesel direct fuel injection with turbo charging
4	Working method or fuel and installation position	D	Diesel engine longitudinal installation
5 + 6	Displacement in 1/10 liter	30	3.0 liters displacement
7	Performance class	O T S	Upper Top Super
8	Revision relevant to approval	0 1	New development First revision

# B57 Engine

## 2. Introduction

### 2.1.2. Engine identification

The 7-digit engine identification is found on the crankcase. The first 6 digits of the engine identification are deduced from the engine type. Only the seventh digit is different. With the engine identification the test number of the type approval certification is located at the 7th position.

The consecutive engine number is embossed above the engine identification. Using these two numbers the engine can be clearly identified by the manufacturer.

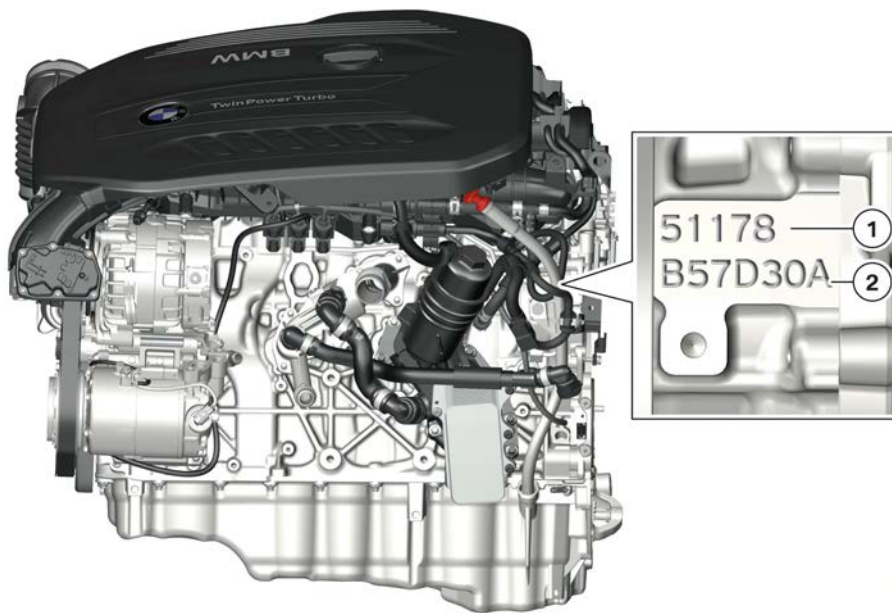

TD15-0046

Engine identification for B57 engine

Index	Explanation
1	Engine number
2	Engine identification

# B57 Engine

## 2. Introduction

### 2.2. Technical data

The following table provide a comparison of the N57TU engine with the B57 engine.

	Unit	N57D3001 (F02 740d)	B57D3000 (G30 540d xDrive)
Design		6 cylinders/in-line	6 cylinders/in-line
Displacement	[cm <sup>3</sup> ]	2993	2993
Bore/stroke	[mm]	84/90	84/90
Valves per cylinder		4	4
Compression ratio	[ε]	16.5 : 1	16.5 : 1
Power output at engine speed	[kW/(HP)] [rpm]	190 (258) 4000	195 (265) 4000
Power output per liter	[kW/l]	63,5	65,2
Torque at engine speed	[Nm] [rpm]	560 1500 – 3000	620 2000 – 2500
Engine control		DDE 7.41	DDE 8.32
Exhaust emission standards		Euro 5/LEV II	Euro 6/LEV III
Maximum speed	[km/h]	250	250
Acceleration 0 – 100 km/h	[s]	6.1	6.1

# B57 Engine

## 2. Introduction

### 2.2.1. Performance diagram

Full-load diagram for B57D3000

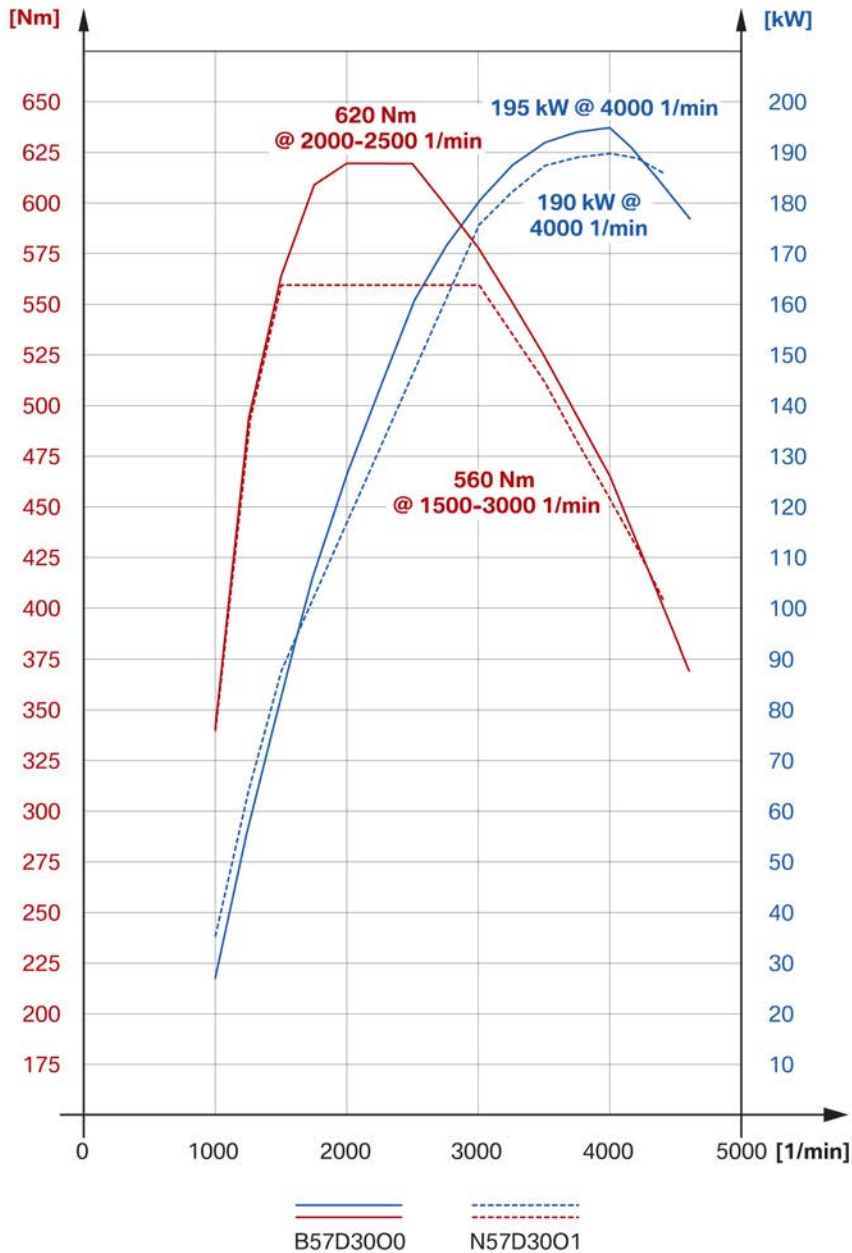

Full-load diagram for B57D3000

TD14-1654

# B57 Engine

## 2. Introduction

### 2.3. Model

<b>Series</b>	<b>B57D3000</b>
G30	540d xDrive

### 2.4. Innovations

The following tables will provide you with a short overview of the new features of the two engines.

	<b>N57D3001</b>	<b>B57D3000</b>
Electric arc wire-sprayed cylinder barrels		●
Tensioned camshaft sprocket		●
Synergy thermo-acoustic capsule (SynTAK)		●
Map-controlled oil pump		●
Oil spray nozzle with piston cooling valve	●	
Centrally controlled piston cooling		●
Vacuum controlled coolant pump		●
VNT exhaust turbocharger	●	●
High-pressure exhaust-gas recirculation	●	●
Low-pressure exhaust-gas recirculation		●
Maximum fuel injection pressure	1800 bar	2500 bar
Solenoid valve injector	●	
Piezo injector		●
Digital Diesel Electronics	7.41	8.32
Preheating control	DDE external	DDE internal
Combustion chamber pressure sensor		●
Hot film air mass meter	Bosch HFM 6	Bosch HFM 8

# B57 Engine

## 2. Introduction

### 2.5. Modular design

Due to the use of the modular design strategy, in the Bx7 and Bx8 engines, not only could numerous common and synergy parts be taken over, but a strategy of service simplification was also followed. Common parts are understood to be the use of components which are used in an unmodified form in various products, but are not standard parts. In contrast, synergy parts are identical in their operating principle, but are adapted to the different engine requirements.

Thanks to the modular design strategy, in the service area, the range of replacement parts was reduced, resulting in simplified stock keeping. The number of newly required special tools needed for the repair of the B57 engine could be reduced greatly. This means that it is possible to continue to use special tools which are already available.

As things stand, 40 tools for the B57 engine could be taken over from previous engine ranges. Only 4 tools were reworked or newly developed. It was not only possible to reduce development costs; there were also the following advantages in the area of service:

- Lower special tool costs.
- The space required for new tools was reduced and stock keeping therefore simplified.
- Stock tools can continue to be used.

In order to repair the B57 engine correctly, the following special tools were also added:

- Engine mounting to fix the engine to the assembly stand.
- Gauge for timing the high pressure pump in relation to the crankshaft.
- Supplementary set for the leakage test of the cylinder head.
- Adapter for measuring the oil pressure.

# B57 Engine

## 3. Engine Mechanical

### 3.1. Engine housing

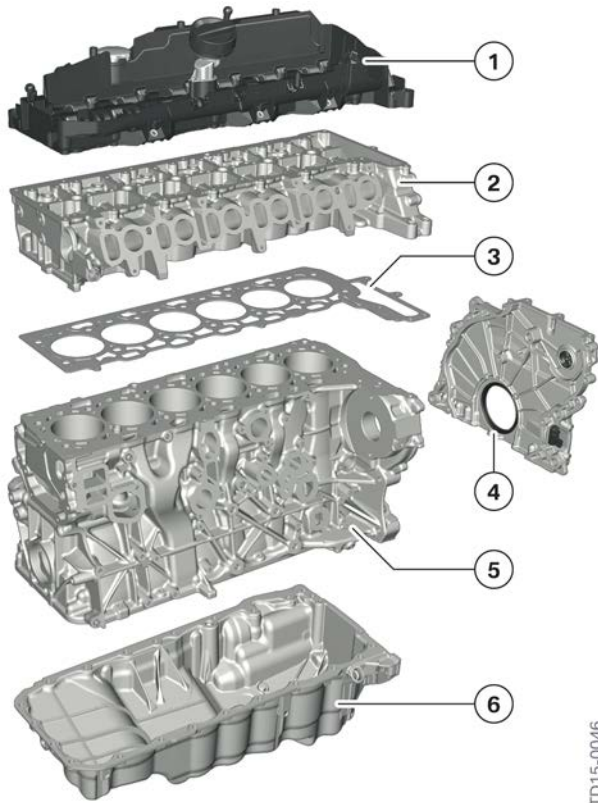

TD15-0046

Engine housing of B57 engine

Index	Explanation
1	Cylinder head cover
2	Cylinder head
3	Cylinder head gasket
4	Timing case cover
5	Cylinder crankcase
6	Oil sump

# B57 Engine

## 3. Engine Mechanical

### 3.1.1. Cylinder head cover

The cylinder head cover seals up the cylinder head at the top. Another task of the cylinder head cover is the regulation of the internal crankcase pressure. The so-called crankcase ventilation is integrated in the cylinder head cover.

#### Crankcase venting components

During engine operation, blow-by gases collect in the depressurized crank space due to piston ring/cylinder leakage. These blow-by gases mainly consist of unburned fuel and exhaust gas. This gas is mixed with engine oil mist in the crankcase. The volume of the blow-by gases is dependent on the engine speed and the load, amongst other factors.

Without crankcase ventilation, these gases would lead to unwanted, excess crankcase pressure. This excess crankcase pressure produces oil leakage at the seals.

The functions of the crankcase ventilation are described in the following:

- Ventilation to depressurize the crankcase.
- Reduction of the oil content in the blow-by gases.
- Recirculation of these blow-by gases with reduced oil content into the clean air pipe, upstream of the turbocharger inlet.

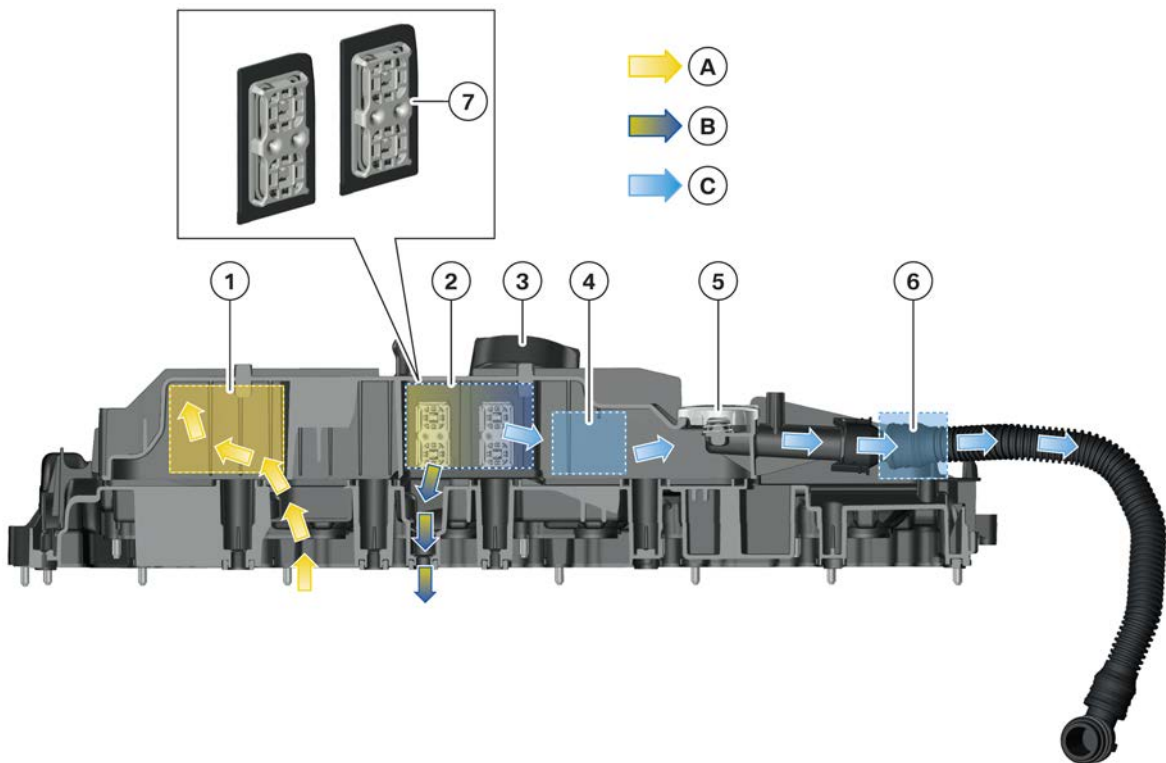

Cylinder head cover B57 engine

TD15-0048



# B57 Engine

## 3. Engine Mechanical

Index	Explanation
A	Unclean blow-by gas mixed with oil (untreated air)
B	Motor oil
C	Clean blow-by gas (clean air)
1	First settling chamber
2	Fine separator
3	Sealing cap of the oil filler neck
4	Second settling chamber
5	Pressure control valve
6	Blow-by gas inlet to clean air pipe
7	Spring plates

The suction power of the exhaust turbocharger creates a vacuum in the clean air pipe. The pressure control valve sets a vacuum of 37 mbar in the crankcase. Due to the pressure difference between the crankcase and the clean air pipe, the blow-by gases are fed through the oil separation system of the cylinder head cover.

### 3.1.2. Cylinder head

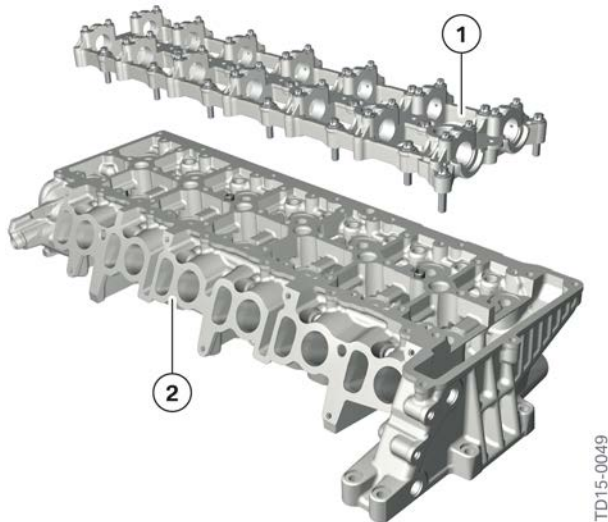

Overview of the cylinder head for the B57 engine

Index	Explanation
1	Camshaft support
2	Cylinder head

# B57 Engine

## 3. Engine Mechanical

In the cylinder head, there is the gas exchange between fresh air, the fuel-air mixture and exhaust gas. It therefore influences:

- Power output
- Torque
- Exhaust emissions
- Fuel consumption
- Acoustics

The cylinder head in the B57 engine has the following characteristics:

- Material: AISI7MgCU0.5
- Two-part cylinder head with camshaft support
- Cross-flow cooling
- 4 valves per cylinder
- Parallel valve arrangement (parallel to the cylinder axes)
- Tangential and swirl ports

### 3.1.3. Cylinder head gasket

A three-layer metal gasket is used as the cylinder head gasket and is available in three different thicknesses depending on the respective piston protrusion. The thickness is indicated in the cylinder head gasket by holes, where one hole signifies the thinnest and three holes signify the thickest.

# B57 Engine

## 3. Engine Mechanical

### 3.1.4. Engine block

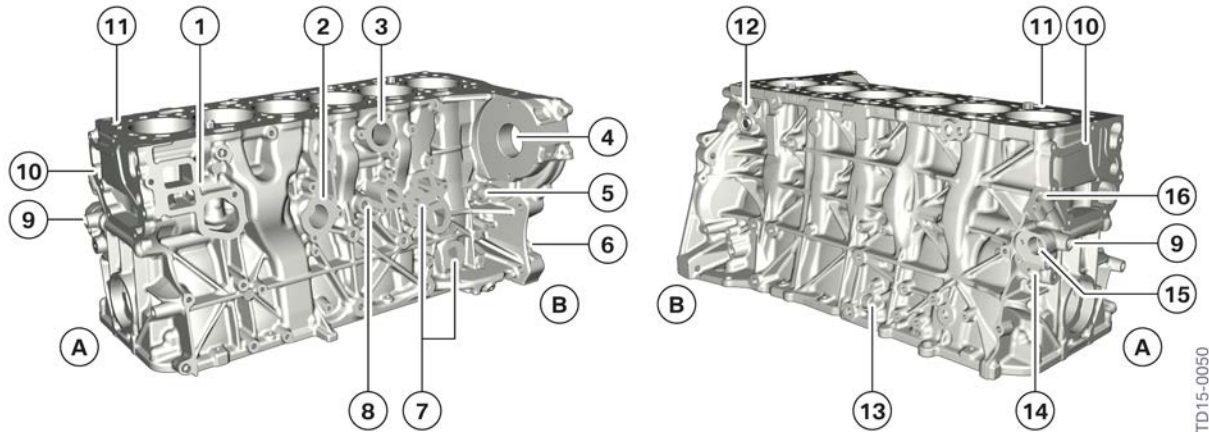

Side view of engine block in the B57 engine

Index	Explanation
A	Belt side
B	Transmission side
1	Sealing surface, coolant pump
2	Sealing surface, secondary thermostat (coolant inlet)
3	Sealing surface, secondary thermostat (coolant outlet)
4	Mounting flange of the high pressure pump
5	Assembly hole (characteristic map-controlled valve)
6	Assembly hole (vacuum connection)
7	Sealing surface, oil filter module
8	Assembly hole (oil pressure sensor)
9	Assembly hole (oil pressure switch)
10	Sealing surface for primary thermostat
11	Closed deck
12	Connection of coolant feed line to the SCR metering unit, to low-pressure stage compressor housing cooling (only B57D30T0, not US)
13	Engine oil return from exhaust turbocharger
14	Assembly hole (hydraulic valve)
15	Assembly hole (solenoid valve)
16	Engine oil feed to exhaust turbocharger

The engine block of the B57 engine has been completely redesigned and draws on the concept of the N57TU engine block. During development, attention was paid to standardizing as many interfaces as possible with the crankcases of the BMW modular engine system so as to reduce the number of mounted parts and ancillary components.

# B57 Engine

## 3. Engine Mechanical

Familiar design features from the N57TU engine are:

- Heat-treated full aluminium crankcase made from AlSi7.
- Closed Deck and Deep Skirt designs for secure handling of high loads.
- Bridge holes for temperature reduction in the cylinder bridge.
- Sintered main bearing cap with embossed teeth.
- Cross flow cooling concept.

In addition, the B57 engine has the following new developments to the crankcase:

- Two-part water jacket and therefore modified flow control in the cylinder crankcase, for optimal cooling even at the highest temperatures.
- Cylinder walls coated by electric arc wire spraying.
- To save weight, oil returns are cast rather than drilled.
- Additional oil ducts, designed for the use of a characteristic map-controlled oil pump, as well as centrally controlled piston cooling.

# B57 Engine

## 3. Engine Mechanical

### Two-part water jacket

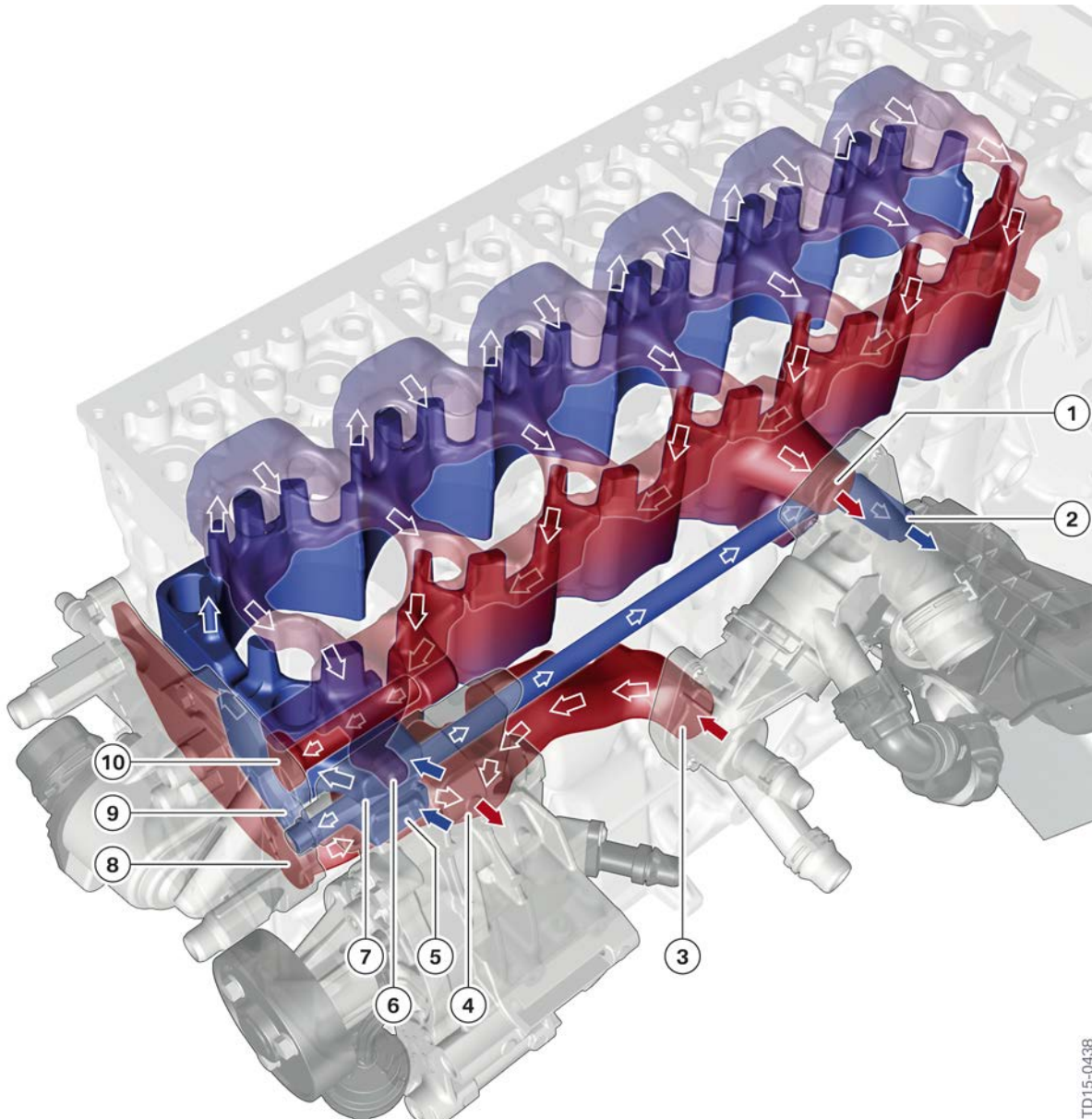

TD15-0438

Water jacket, B57 engine

Index	Explanation
1	Coolant outlet to radiator
2	Coolant supply to the engine oil-to-coolant heat exchanger
3	Coolant return, secondary thermostat to coolant pump
4	Intake side, coolant pump
5	Coolant duct to the exhaust-gas recirculation coolers and the engine oil-to-coolant heat exchanger

# B57 Engine

## 3. Engine Mechanical

Index	Explanation
6	Connection, coolant ventilation line
7	Coolant duct to cylinder crankcase
8	Thermostat housing – return to coolant pump
9	Thermostat housing – supply to the exhaust-gas recirculation coolers
10	Coolant duct for bypass

The modified flow control in the crankcase was designed to enable optimal cooling even at the highest temperatures. **Due to this modification, it is also possible to connect the coolant flow via the vacuum controlled coolant pump to the crankcase (7).** This has a positive effect due to a shortened warm-up phase. In the warm-up phase, the coolant duct (5) to the high and low-pressure exhaust-gas recirculation coolers (9) also serves as heating for the engine oil in the oil-to-coolant heat exchanger (2).

The coolant pump delivers the coolant to the hot exhaust side of the cylinder crankcase and absorbs the heat energy. From there, the coolant is only pumped upwards into the cylinder head and in the cross-flow principle to the cooler intake side. Back in the cylinder crankcase, depending on the coolant temperature, the coolant either flows directly via the bypass (10) or via the radiator (1) to the return of the thermostat housing (8) and from there to the coolant pump (4).

The two-part water jacket provides the following advantages:

- Uniform heat distribution in the entire cylinder head.
- Improved cooling of the cylinder bridges.
- Prevention of additional loss of pressure in the coolant circuit.

### Electric arc wire spraying



Electric arc wire spraying procedure at BMW

# B57 Engine

## 3. Engine Mechanical

In the B57 engine, thermally sprayed cylinder liners are used instead of the usual grey cast iron inserts. In this procedure a conductive metal wire is heated until it melts in an electric arc. The molted metal is then sprayed onto the cylinder liners at high pressure. The layer, which is just about 0.2 mm thick, is extremely wear-resistant and facilitates an efficient transfer of heat from the combustion chambers to the crankcase, and from there to the coolant ducts. Although the weight was reduced in comparison to the grey cast iron cylinder liners (due to the minimal thickness of the layer) the finish product is more robust to withstand the increased cylinder pressures.

The advantages of LDS technology are:

- Lower weight
- High wear resistance
- Good heat dissipation to the crankcase
- Lower internal engine friction due to excellent sliding properties



---

**Due to the thin material application during the electric arc wire-spraying procedure, subsequent machining of the cylinder barrels is not possible.**

---



---

**Before cleaning the sealing surface on the cylinder crankcase to the cylinder head, the feed lines of the oil ducts must be sealed. Furthermore, no machining tools may be used for the cleaning.**

---

**In order to prevent damage to the engine, please observe the current repair instructions.**

---

### 3.1.5. Oil sump

Depending on the drive concept, 2 oil sumps are used in the B57 engine. The sealing of the oil sump to the cylinder crankcase is made using Loctite 5970 (taken over from N57 engine).

In addition to the oil-level sensor, the B57 engine has an oil dipstick to check the oil level.



---

To ensure perfect tightness of the oil sump against leaks, please observe the current repair instructions.

---

# B57 Engine

## 3. Engine Mechanical

### 3.2. Crankshaft drive

The crankshaft drive is the functional group of components which converts the combustion chamber pressure into kinetic energy. Here, the up and down motion of the piston is converted into a rotational movement at the crankshaft. In comparison to the N57TU engine, the crankshaft drive only has minor modifications.



Crankshaft drive of the B57 engine

Index	Explanation
1	Piston
2	Connecting rod
3	Crankshaft

#### 3.2.1. Crankshaft

Crankshaft	Unit	N57TU engine	B57 engine
Manufacture		Forged	Forged
Material		C38modBY	C38modBY
Diameter of the main bearing journal	[mm]	55	55
Diameter of the connecting rod bearing journal	[mm]	50	50
Stroke of the connecting rod bearing journal	[mm]	90	90



# B57 Engine

## 3. Engine Mechanical

Crankshaft	Unit	N57TU engine	B57 engine
Throw angle	[crankshaft degrees]	120	120
Number of counterweights		4	4
Number of main bearing positions		7	7
Position of thrust bearing		Bearing 4	Bearing 4

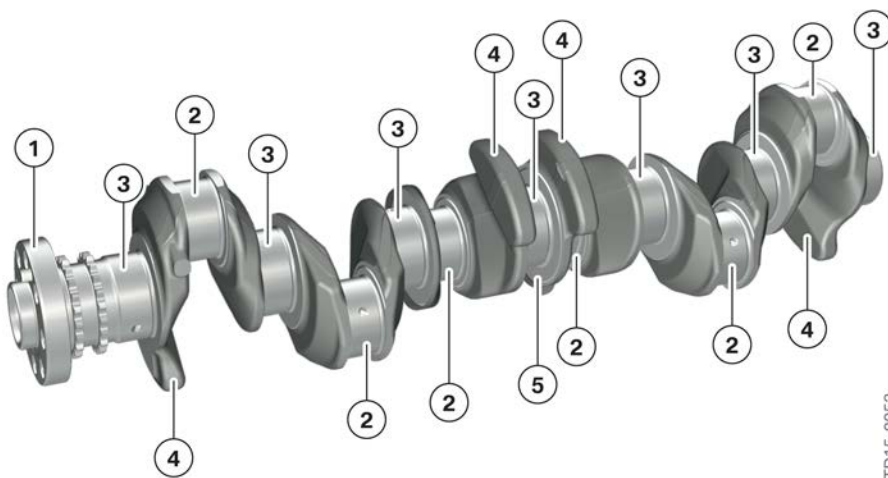

Crankshaft of B57 engine

Index	Explanation
1	Output flange
2	Connecting rod bearing journal
3	Main bearing journal
4	Counterweight
5	Contact surface of the thrust bearing

The 6-cylinder in-line engine is the best engine design in terms of smooth running. This is true because the design allows all forces to cancel each other out. With this engine design, no additional measures must therefore be taken to neutralize the rotating (rotary) or oscillating (up and down) masses. The crankshaft is equipped with 4 counterweights to neutralize these forces. These counterweights generate an overall symmetry around the crankshaft axis, thus enabling smooth engine running.

### Crankshaft bearing

The crankshaft is mounted using different bearing shells. The bearing shells in the unloaded zone of the bearing seat have oil holes and a surrounding groove for the oil supply. The highly stressed bearing shells in the main bearing cap are designed as three-component bearings.

# B57 Engine

## 3. Engine Mechanical

The crankshaft thrust bearing positions the crankshaft longitudinally and has to absorb forces from the clutch control or the torque converter in the case of automatic transmissions. The B57 engine also has thrust bearings with laser welded thrust washers on the top and bottom bearing shell. This enables simple installation.

During operation, the welded connection loosens and the thrust washers are located between the bearing seat and crankshaft; they are able to move and yet cannot become lost. The system therefore operates smoothly and has a low level of wear.



---

**When replacing the crankshaft or the crankshaft main bearing shells, a bearing shell classification must also be carried out on the B57 engine. Please refer to the current repair instructions for the exact procedure.**

**Please pay attention when working with bearing shells as the bearing shell layer can easily become damaged.**

---

### 3.2.2. Connecting rod

Connecting rods are placed under stress due to large push/pull and bending/buckling forces. They must also be light due to inertia forces. This is why the well-known drop-forged cracked connecting rods are used.

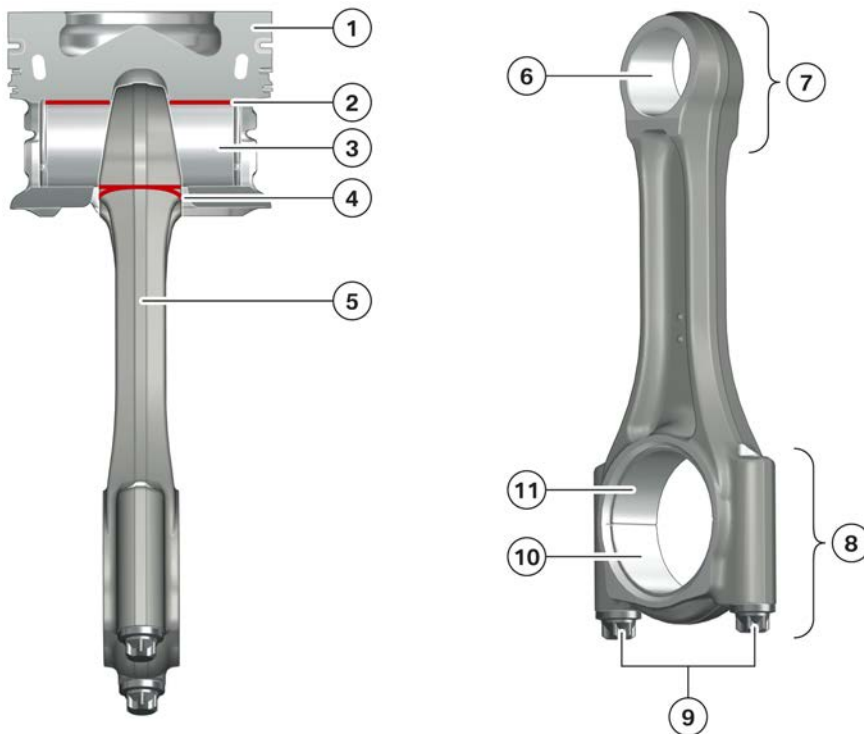

Connecting rod of B57 engine

TA13-1943

# B57 Engine

## 3. Engine Mechanical

Index	Explanation
1	Piston
2	Area transferring the force
3	Wrist pin (diamond-like carbon coating)
4	Connecting rod bearing bush with shaped bore hole
5	Connecting rod
6	Connecting rod bush
7	Small connecting rod eye (trapezoidal shape)
8	Large connecting rod eye (cracked)
9	Connecting rod bolts of the connecting rod bearing cap
10	Connecting rod bearing shell of the connecting rod bearing cap
11	Connecting rod bearing shell of the connecting rod



**If a connecting rod bearing cap is mounted the wrong way round or mounted on another connecting rod, the fracture pattern of both parts is destroyed and the connecting rod bearing cap is no longer centred. In this event the entire connecting rod set must be replaced by new parts.**

### Weight classification

Because of the moving inertia forces, this also a question of the weight distribution between the small and large connecting rod eye. This influence is extremely complex, as the large connecting rod eye completes a circular motion, while the small connecting rod eye describes a rectilinear forward-and-back motion.

Modern manufacturing procedures enable the manufacturing parameters to be monitored so closely that production can be carried out with a low weight tolerance. To guarantee smooth engine running, the connecting rods are weighed and divided into weight classes. These weight classes are then combined to make a connecting rod set.

# B57 Engine

## 3. Engine Mechanical

### 3.2.3. Piston

The pistons are made from an aluminium-silicon alloy. Due to the material pairing of the piston with the cylinder wall, the surface of the piston skirt is coated with graphite (Graphal process). Due to this coating, which is only 0.02 - 0.04  $\mu\text{m}$  thick, the friction could be reduced and the noise characteristics improved.

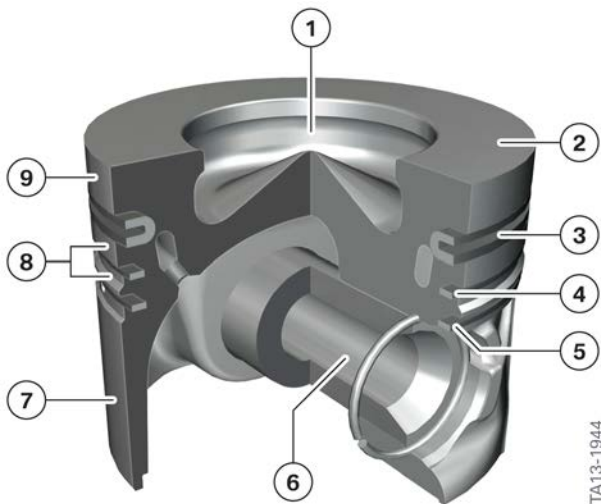

Piston of B57 engine

Index	Explanation
1	Combustion bowl
2	Piston crown
3	1st piston ring (plain rectangular compression ring)
4	2nd piston ring (taper faced piston ring)
5	3rd piston ring (oil scraper ring with spiral expander)
6	Wrist pin (diamond-like carbon coating)
7	Piston skirt
8	Ring bar
9	Fire land

# B57 Engine

## 3. Engine Mechanical

### Bowl rim remelting

A further distinguishing feature of the B57 engine is the design of the piston. In the B57D30T0 the highly stressed critical area between the piston crown and the rim to the piston recess is remelted by a laser under controlled conditions. This results in an optimum structure and thereby increases thermal load capacity by up to 60%.

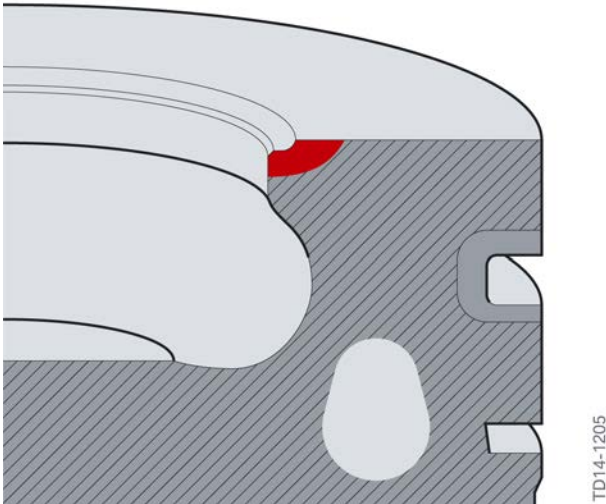

Bowl rim remelting, B57D30T0



---

**During the installation of piston rings, please observe the repair instructions. Piston rings must not be inserted the wrong way round. Incorrect installation will result in engine damage.**

**A damaged or broken oil scraper ring cannot be detected while it is mounted. The effects become apparent only after a certain number of miles have been driven.**

---

### 3.3. Chain drive

The following special features should be mentioned for the chain drive of the B57 engine:

- Camshaft drive at the engine output end (rear)
- Two-part chain drive to drive the high pressure pump and camshafts
- Simple sleeve-type chains
- Oil/vacuum pump driven via a separate drive chain
- Plastic tensioning rails and guide rails
- Hydraulic chain tensioner with spring preload
- Vibration damper on the camshaft sprocket of the high pressure pump

# B57 Engine

## 3. Engine Mechanical

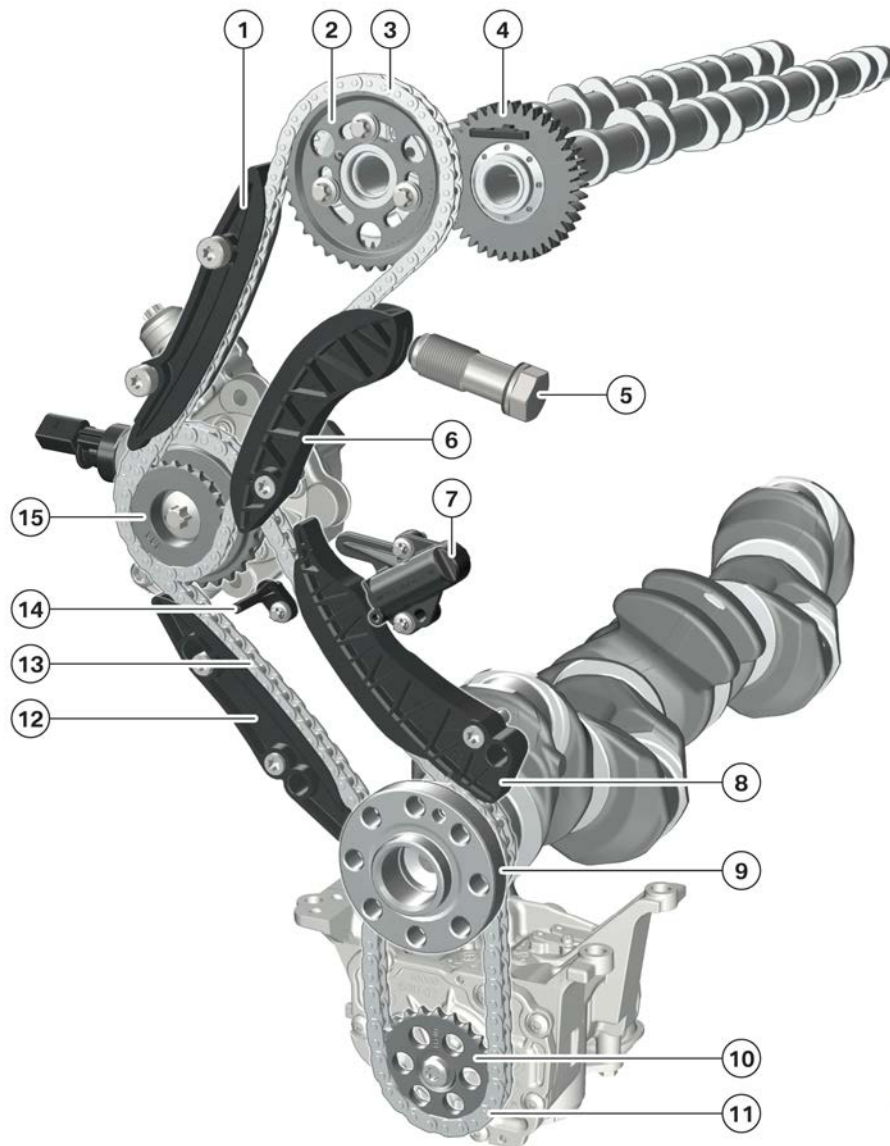

TD15-0398

Chain drive of B57 engine

Index	Explanation
1	Guide rail, top
2	Intake camshaft sprocket
3	Upper timing chain
4	Tensioned exhaust camshaft gear
5	Chain tensioner, top
6	Tensioning rail, top
7	Chain tensioner, bottom
8	Tensioning rail, bottom

# B57 Engine

## 3. Engine Mechanical

Index	Explanation
9	Crankshaft
10	Camshaft sprocket, oil/vacuum pump
11	Timing chain, oil/vacuum pump
12	Guide rail, bottom
13	Lower timing chain
14	Oil spray nozzle
15	Camshaft sprocket, high pressure pump with vibration damper

### 3.3.1. Camshaft sprocket of the high pressure pump

A vibration damper is integrated in the B57 engine on the camshaft sprocket of the high pressure pump. This reduces the effects which may arise due to oscillation of the timing chains.

This vibration is caused by the so-called "polygon effect". Here, the timing chain does not loop around the camshaft sprocket in a circular way, but in the form of a polygon. If the camshaft sprocket then turns, irregular rotational movement is caused due to the polygon application of the timing chain. The speed of the timing chain then fluctuates in equal intervals around a mid speed. This leads to stimulation of the timing chain which can lead to oscillation.

Without a vibration damper, this possible oscillation of the timing chain, also known as a chain whining noise, would be transferred via the high pressure pump to the engine structure.

### 3.3.2. Timing chain

All of the timing chains used in the B57 engine are simple sleeve-type chains. On a sleeve-type chain, the tooth flanks of the camshaft sprocket always touch the fixed sleeves at the same point. It is therefore particularly important for such chain drives to be correctly lubricated.

For various reasons, the timing chain is subject to chain extension. This either results from the operating conditions (thermal expansion), setting operations (run-in behavior) or is wear-related. As already familiar from previous diesels the B57 engine also has chain pins coated in chrome nitride. This helps to reduced the wear of the chain by up to 70% compared to non-coated sleeve-type chains.

# B57 Engine

## 3. Engine Mechanical

### 3.4. Valve gear

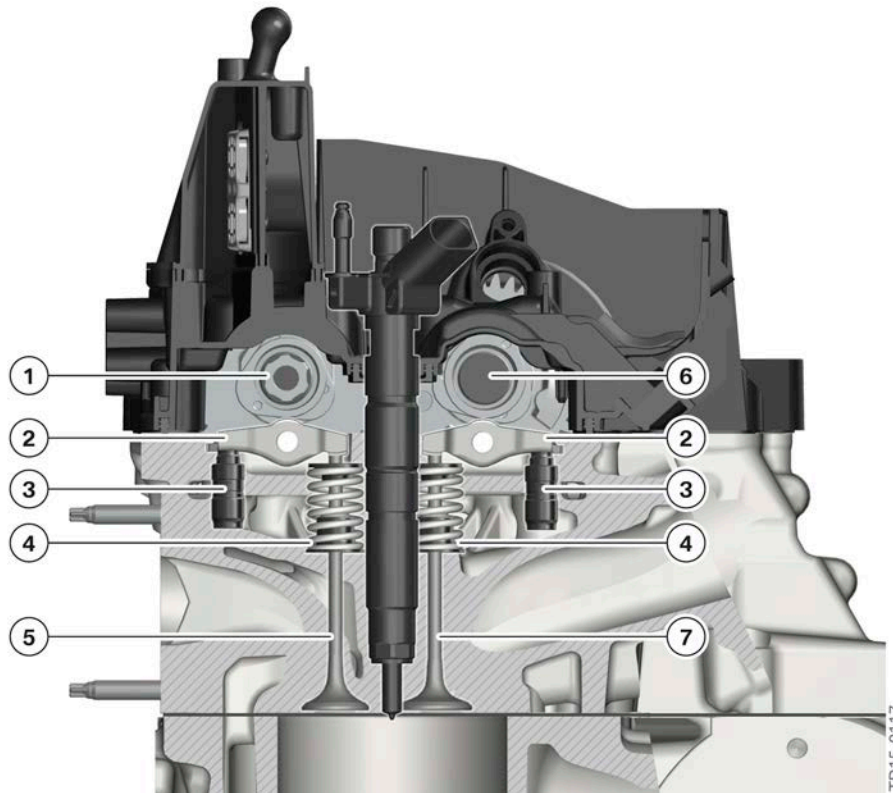

Valve gear, B57 engine

Index	Explanation
1	Exhaust camshaft
2	Roller cam follower
3	Hydraulic valve clearance compensation element
4	Valve spring
5	Exhaust valve
6	Intake camshaft
7	Intake valve

#### 3.4.1. Timing

The timing of the B57 engine is identical to that of the N57TU engine.

The following chart contains the timing also specifications for the N57D3001 engine.



# B57 Engine

## 3. Engine Mechanical

Explanation	Unit	Intake	Exhaust
Valve diameter	[mm]	27.2	24.6
Max. valve lift	[mm]	8.5	8.5
Spread	[crankshaft degrees]	100	105
Valve opens	[crankshaft degrees]	352.4	140.7
Valve closes	[crankshaft degrees]	567.1	363.9
Valve opening period	[crankshaft degrees]	214.7	223.1

### 3.4.2. Camshaft

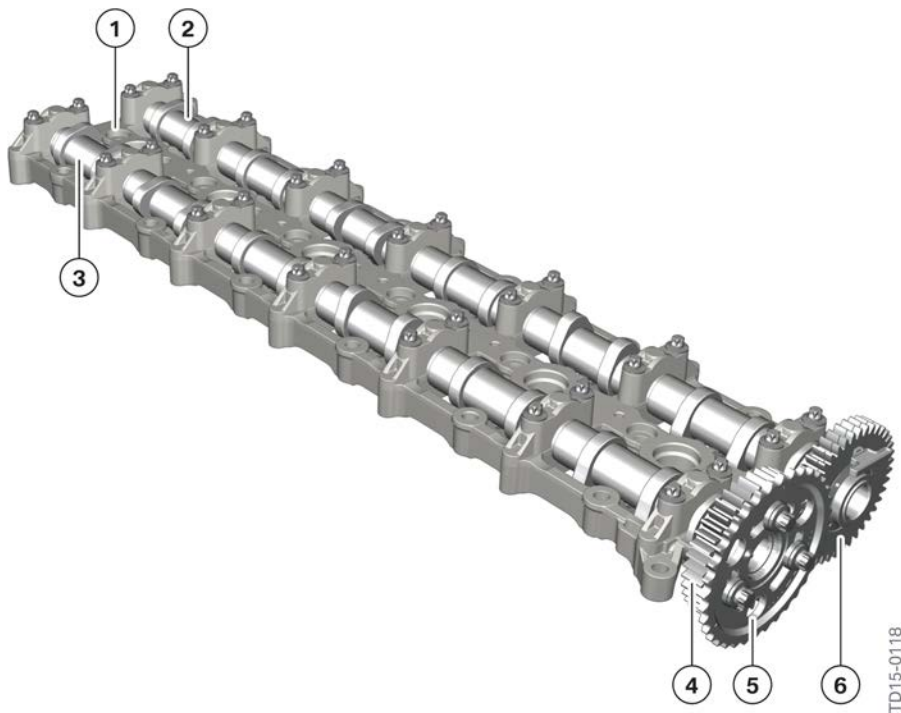

Camshafts in B57 engine

Index	Explanation
1	Camshaft support
2	Exhaust camshaft
3	Intake camshaft
4	Intake camshaft gear
5	Intake camshaft sprocket
6	Tensioned exhaust camshaft gear

The camshafts control the movement of the valves, in accordance with the engine firing order.

# B57 Engine

## 3. Engine Mechanical

In order to save weight, the B57 engine has assembled camshafts, just like its predecessor. These are composed of a pipe, the cam lobes and gears.

The gears have the following special features:

- Sensor geometry for the camshaft sensor function.
- Mounting flange for the camshaft sprocket.
- Mounting flats for adjusting the camshaft timing.
- Tensioned exhaust camshaft gear.

### Tensioned exhaust camshaft gear

The intake camshaft drives the exhaust camshaft, as already familiar from the N57TU engine, by using a straight (spur) gear. The straight (spur) gears help to reduce efficiency losses in comparison to helical gears, despite a thinner size.

The exhaust camshaft gear is divided into a fixed gear and an idler. The fixed gear is connected to the camshaft via a retaining ring and is primarily used for the power transmission. The idler is mounted radially at the fixed gear. Via a pre-loaded “omega” spring, which is supported on one side at the fixed gear and on the other at the idler, the tooth flanks of the idler and fixed gear expand in the teeth of the intake camshaft gear. This results in perfect play compensation at the tooth flanks and quiet rolling of the straight (spur) gears.

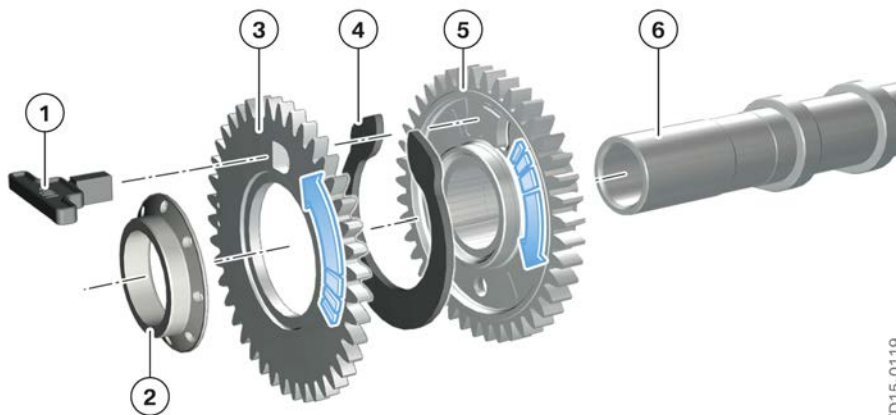

Tensioned exhaust camshaft gear, B57 engine

Index	Explanation
1	Installation pin
2	Retaining ring
3	Exhaust camshaft, idler
4	Omega spring
5	Exhaust camshaft, fixed gear
6	Exhaust camshaft

# B57 Engine

## 3. Engine Mechanical



When working on the exhaust camshaft, please note that it is a pre-tensioned gear. The pre-tensioned gear is supplied with an installation pin, which must be removed after installation. Please refer to the current repair instructions for the correct procedure.

### 3.5. Belt drive

The belt drive is responsible for the slip-free drive of the ancillary components in all load conditions.

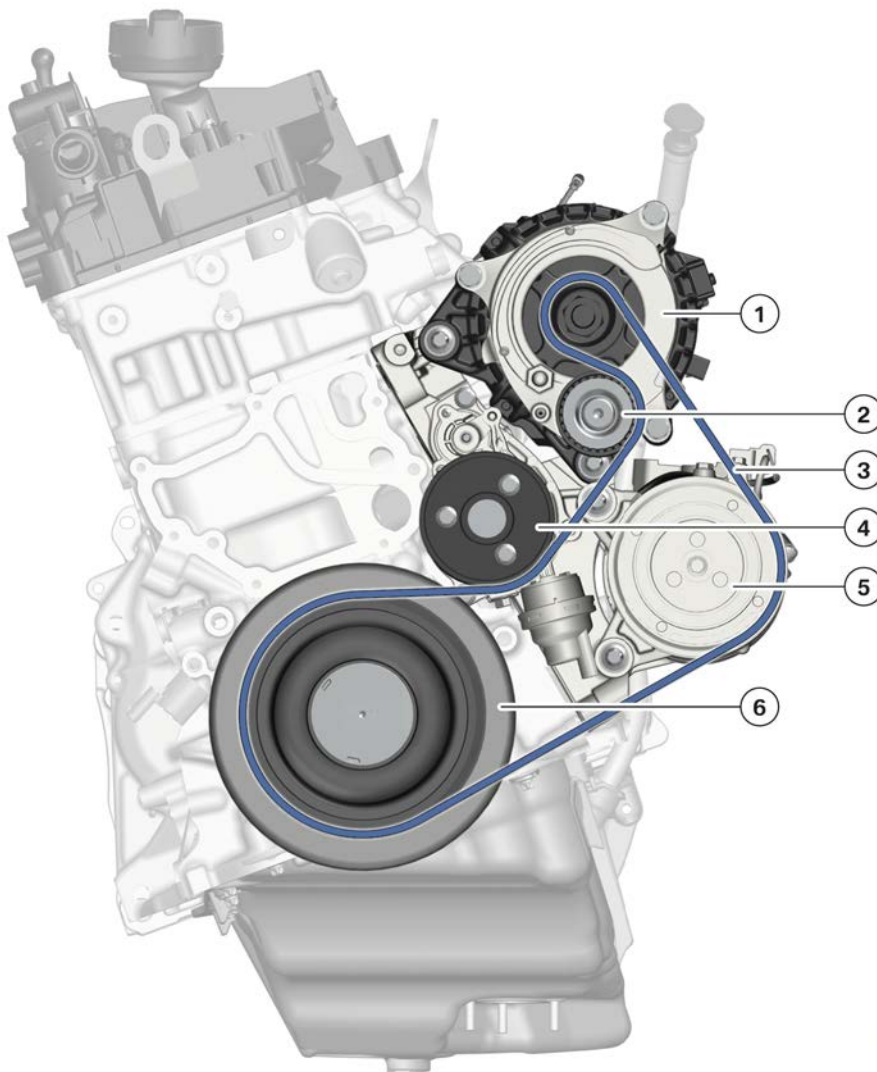

B57 engine belt drive

TD15-0120

# B57 Engine

## 3. Engine Mechanical

Index	Explanation
1	Alternator with screwed on mechanical belt tensioner
2	Tensioning pulley
3	Ribbed V-belt
4	Coolant pump
5	Air conditioning compressor
6	Torsional vibration damper

As all ancillary components are only driven by one drive belt, this is a single-level belt drive.

The drive belt is subject to extension on account of thermal expansion over its service life. To be able to transmit the required torque over the entire service life, the drive belt must constantly rest against the belt pulleys with a specific force. For this, belt tension is applied via a mechanical belt tensioner.

### 3.5.1. Torsional vibration damper

The B57 engine's vibration damper is a visco damper at the belt drive. Here, the flywheel mass is not fixed to the hub with a damping disc but rather by a viscous fluid. A damping effect is created by alternating shear forces in the viscous fluid which is located in a narrow gap between the hub and the rotating flywheel mass. This concept enables rotary oscillation to be cancelled out excellently for a comparatively low installation volume.

An uncoupled belt pulley is used to protect the ancillary components from rotational irregularities. The belt pulley is separated from the hub by the rubber isolation element, thus reducing the loads at the drive belt.

# B57 Engine

## 3. Engine Mechanical

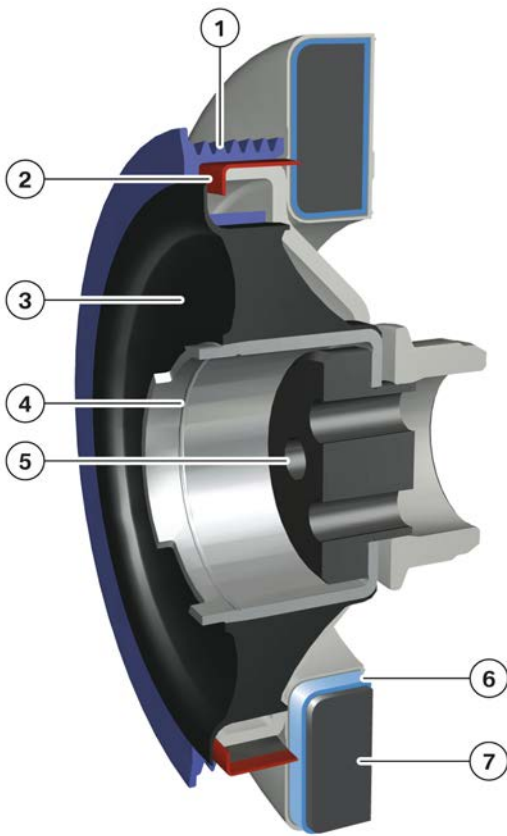

TD15-0122

Torsional vibration damper, B57 engine

Index	Explanation
1	Belt pulley
2	Plain bearing
3	Belt pulley rubber isolation element
4	Uncoupled belt pulley hub
5	Hub with vibration damper housing
6	Viscous fluid
7	Flywheel mass



**To avoid damage to the torsional vibration damper, the engine must not be operated without drive belts.**

# B57 Engine

## 3. Engine Mechanical

### 3.6. Sound insulation

The engine cover is the top cover of the engine and must satisfy certain design requirements in order to guarantee a uniform engine design that meets BMW standards. A fleece material is attached as an additional acoustic measure on the bottom.

All covers must satisfy the specified acoustics requirements and are mounted to various engine components. The absorption mat has an additional sealing function to protect against moisture and dirt contamination in the injector area.



Sound insulation, B57 engine

TD15-0123

# B57 Engine

## 3. Engine Mechanical

Index	Explanation
1	Engine cover
2	Absorption mat
3	Acoustic cover, front
4	Acoustic cover, rear
5	Acoustic cover, oil sump



**Always ensure proper installation of all covers. A cover which has been incorrectly fitted may cause interference noises. Furthermore, the cover also guarantees the thermal operating safety of individual engine components.**

### 3.6.1. Thermo-acoustic capsule (SynTAK)

To enhance sound insulation, a three piece, Synergy thermo-acoustic (SynTAK) capsule has been installed. It partially encapsulates the engine with the purpose of reducing engine noise in addition to the sound insulation already installed. Furthermore, this “engine capsule” also contributes to heat retention. This is especially important in the warm-up phase in order to improve the thermal performance of the engine. Heat retention is also enhanced during engine stops by the automatic engine start-stop function.

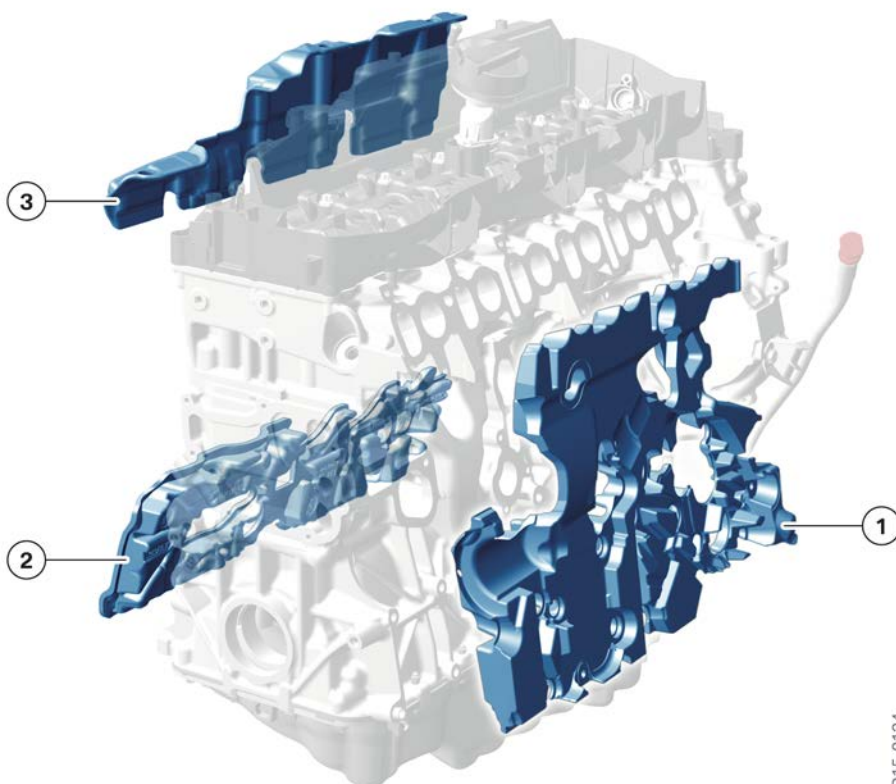

TD15-0124

Synergy thermo-acoustic capsule, B57 engine

# B57 Engine

## 3. Engine Mechanical

<b>Index</b>	<b>Explanation</b>
1	Synergy thermo-acoustic capsule, crankcase, cold side
2	Synergy thermo-acoustic capsule, crankcase, hot side
3	Synergy thermo-acoustic capsule, cylinder head cover, hot side



# B57 Engine

## 4. Oil Supply

### 4.1. Oil circuit

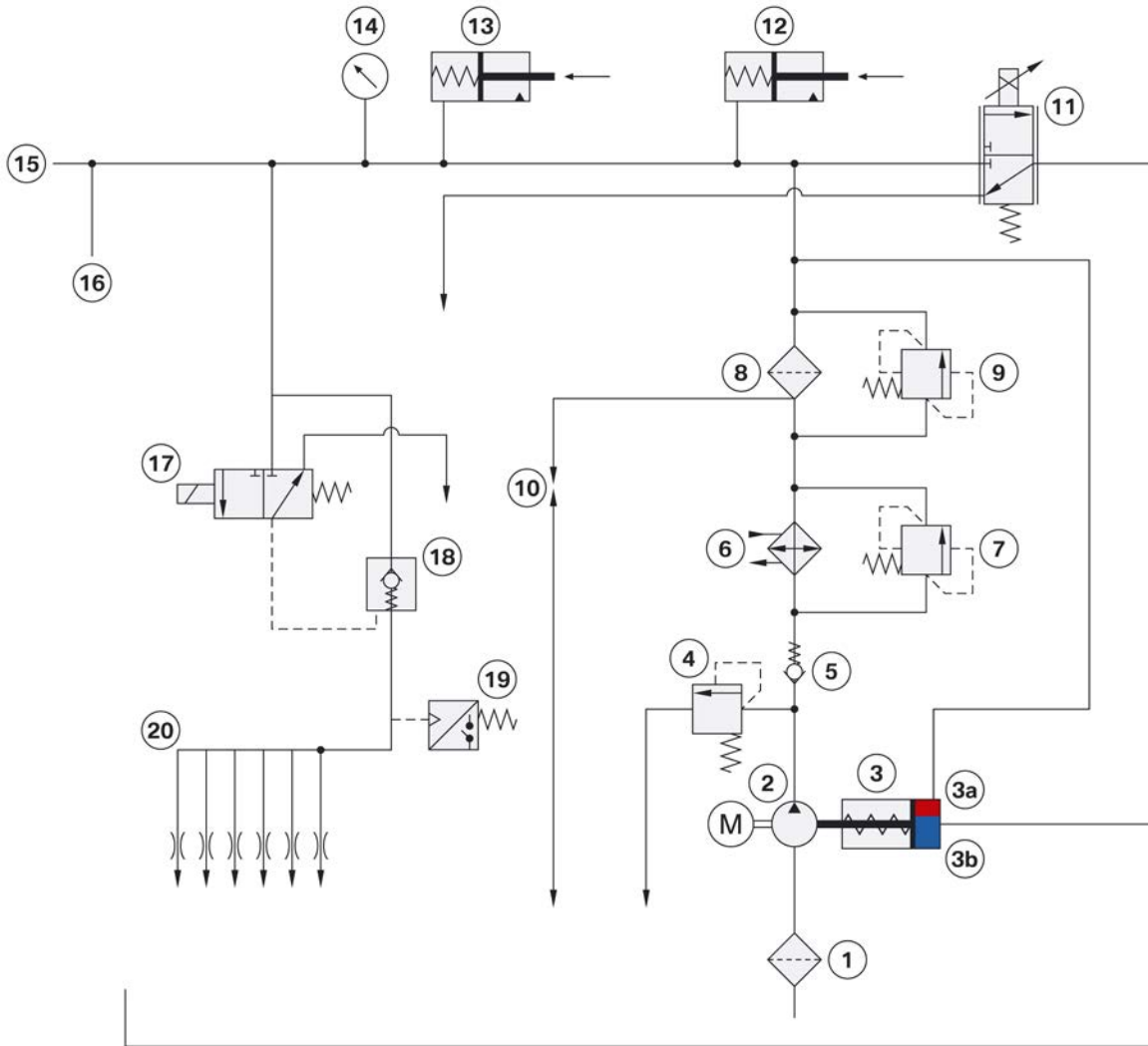

TD15-0125

Schematic diagram of the oil circuit in the B57 engine

Index	Explanation
1	Oil strainer
2	Oil pump/vacuum pump
3	Control element (built-in to pump)
3a	Chamber for second-level control (emergency operation)
3b	Chamber for map-controlled operation (normal operation)
4	Pressure limiting valve (built-in to pump)
5	Non-return valve
6	Engine oil cooler
7	Radiator bypass valve

# B57 Engine

## 4. Oil Supply

Index	Explanation
8	Oil filter
9	Filter bypass valve
10	Oil filter drain (duct is unblocked during filter disassembly)
11	Solenoid valve for characteristic map-controlled operation
12	Lower chain tensioner
13	Upper chain tensioner
14	Oil pressure sensor
15	Lubrication points in cylinder head
16	Lubrication points in crankcase
17	Solenoid valve
18	Hydraulic valve
19	Oil pressure switch (0.3–0.6 bar)
20	Oil spray nozzles

The oil supply of an engine supplies engine oil to all the components which must be lubricated and cooled. The B57 engine is therefore equipped with force-fed circulation lubrication.

With force-fed circulation lubrication the oil is drawn out of the oil sump by the oil pump through an intake pipe and forwarded into the circuit. The oil passes through the full-flow oil filter and from there into the main oil gallery, which runs in the engine block parallel to the crankshaft. Branch ducts lead to the crankshaft main bearings. The crankshaft and connecting rod journals are supplied from the main bearings with oil, as the crankshaft is provided with appropriate holes. Some of the oil is diverted from the main oil duct and directed to the cylinder head to the relevant lubrication points.

The oil finally returns to the oil sump. This occurs either through return ducts or it drips back freely.

# B57 Engine

## 4. Oil Supply

### 4.2. Characteristic map-controlled oil supply

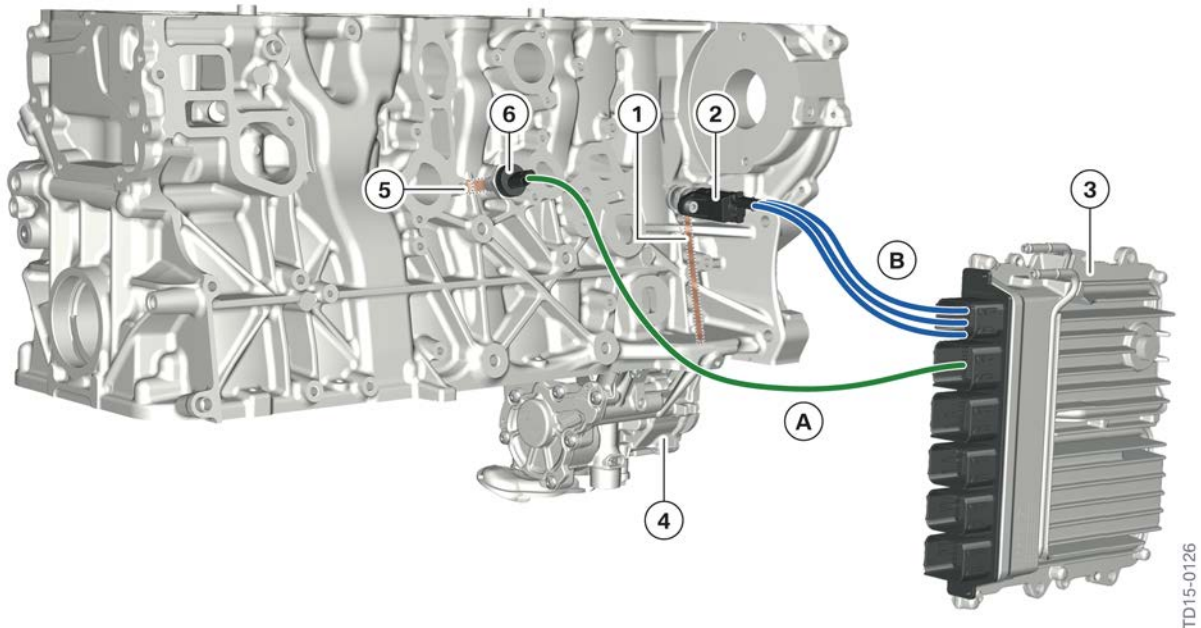

TD15-0126

System overview of characteristic map-controlled oil supply of the B57 engine

Index	Explanation
A	Oil pressure sensor signal
B	Activation of map-controlled control valve
1	Volume oil flow for the control of the vane-type compressor
2	Map control valve
3	Digital Diesel Electronics (DDE 8.32)
4	Vane-type compressor
5	Main oil duct to the oil pressure sensor
6	Oil pressure sensor

The characteristic map-controlled vane-type compressor was already introduced in the previous BMW diesel engines (B37/B47). This function is now (for the first time) also being used in the 6-cylinder diesel engine. Because of this, the drive power of the oil pump and the fuel consumption could therefore be reduced further.

The characteristic map-controlled oil supply guarantees the optimized operating-point supply of oil to the engine. The oil pressure sensor in the oil circuit supplies the actual oil pressure to the DDE and, using the operating condition of the engine, calculates the required set-point oil pressure. A pulse-width-modulated corrective signal is sent to the map-controlled control valve based on the calculated deviation from the set-point. Due to the position of the valve spool, the eccentricity and thus the delivery rate of the oil pump with variable volume flow is modified using a hydraulic controller, thereby adjusting the oil pressure. The valve spool is supplied with filtered oil by the oil circuit.

# B57 Engine

## 4. Oil Supply

### 4.2.1. Map control valve

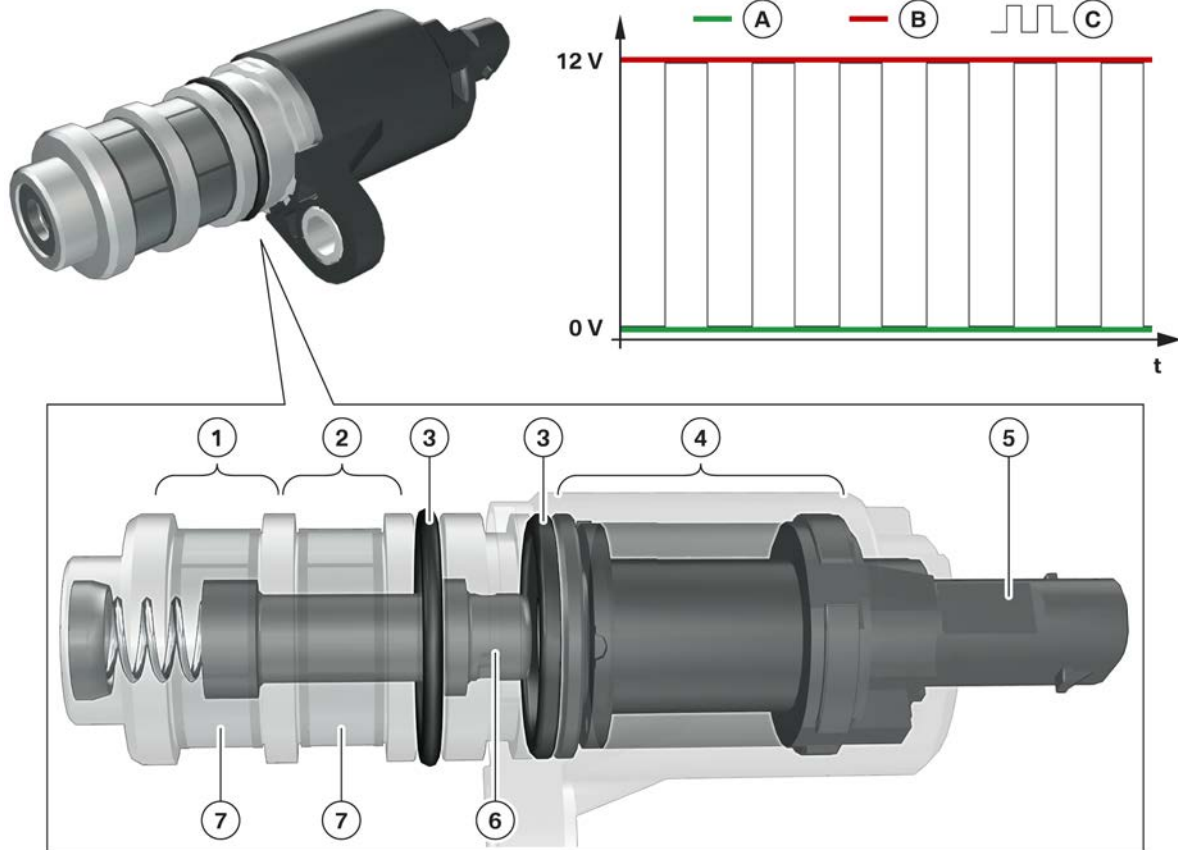

Map control valve

TA13-2155

Index	Explanation
A	Voltage curve, minimum delivery rate
B	Voltage curve, maximum delivery rate
C	Voltage curve, 50% delivery rate
1	Oil duct to the vane-type compressor
2	Oil duct from the oil filter
3	Sealing ring
4	Solenoid coil
5	Electrical connection
6	Valve spool
7	Filter

The characteristic map-controlled control valve is a proportional valve which can continually adjust the valve spool depending on the operation-based request from the DDE.

# B57 Engine

## 4. Oil Supply

### 4.3. Oil pump

The oil pump plays a central role in the map-controlled oil pressure function. The high level of power and the enormous torque, even at low speeds, require a high oil flow rate. This is necessary on account of the high component temperatures and heavily loaded bearings. On the other hand, to achieve low fuel consumption, the oil flow rate must be reduced.

#### 4.3.1. Vane-type compressor oil pump

A fully variable vane-type compressor oil pump is used in the B57 engine. This is driven by a timing chain from the crankshaft with a ratio  $i = 21:23$  (crankshaft : oil pump).

With this oil pump, it is possible to continually adjust the volumetric flow between maximum and minimum delivery. This enables the setting of different oil pressures at all engine operating points and thus reduces the necessary drive power of the oil pump to a minimum.

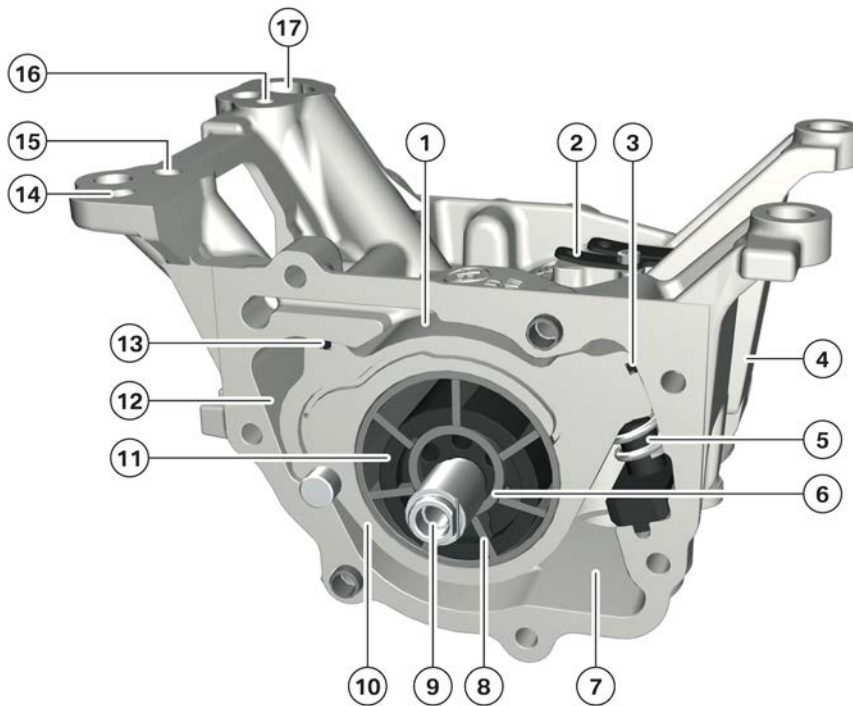

TD15-0127

Vane-type compressor, B57 engine

Index	Explanation
1	Chamber of the map-controlled operation
2	Discharge valves, vacuum pump
3	Sealing strip
4	Pump body
5	Adjusting ring spring
6	Guide ring
7	Intake port

# B57 Engine

## 4. Oil Supply

Index	Explanation
8	Pump blades
9	Drive shaft
10	Adjusting ring
11	Rotor
12	Chamber for second-level control (emergency operation)
13	Sealing strip
14	Vacuum duct, vacuum pump
15	Input, map-controlled duct to the map-controlled chamber
16	Input, second-level control duct to the second-level control chamber
17	Pressure outlet, oil pump

The vane-type compressor has two separate control loops in order to enable normal operation (characteristic map-controlled operation) and emergency operation (second-level control operation).

The minimum delivery rate can only be achieved in characteristic map-controlled operation.

The maximum delivery rate can either be achieved in characteristic map-controlled operation or in second-level control operation.

### Normal operation

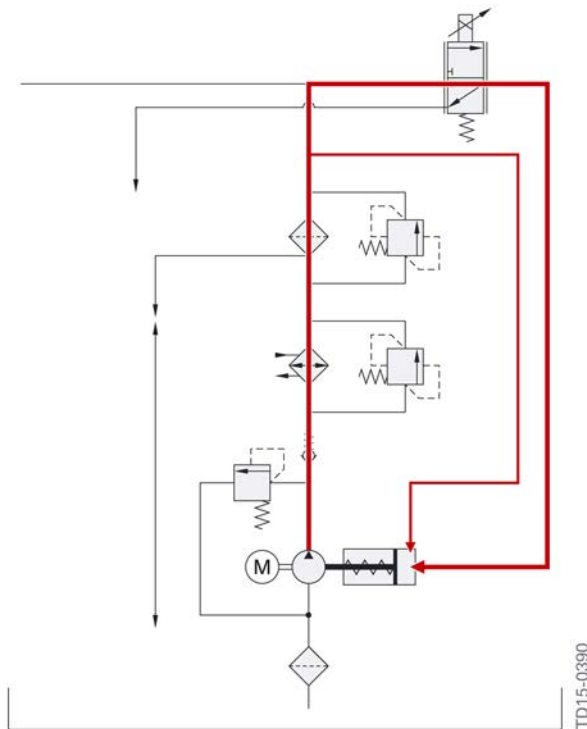

Oil circuit in normal operation

TD15-0390

# B57 Engine

## 4. Oil Supply

The Digital Diesel Electronics records the actual pressure via the oil pressure sensor and compares it to a nominal pressure stored in the characteristic map. The characteristic map-controlled valve is activated by a pulse-width modulated signal, adjusting the nominal pressure. As a result of the change of the oil pressure in the map-controlled chamber, the oil pressure in the main oil duct is changed at the same time.

### Emergency operation

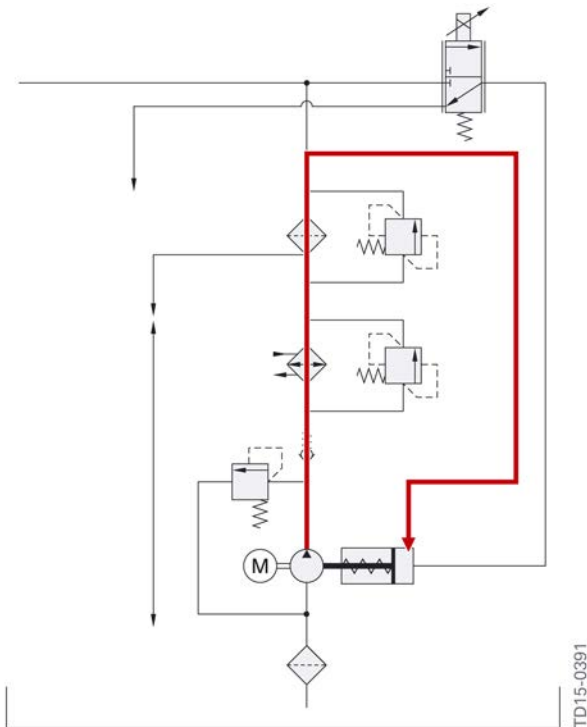

Oil circuit, emergency operation

This control loop is responsible for independently maintaining the vane-type compressor at a constant upper oil pressure level across the entire engine speed range in the case of a fault. The oil pressure is guided directly from the main oil duct to the second-level control chamber. As there are no actuators, this control loop cannot be influenced or switched off.

### Pressure-limiting valve

The pressure limiting valve protects the vane-type compressor and the oil circuit from overloading. This valve opens at an oil pressure of  $> 11$  bar and directs the excess engine oil back to the oil sump. This valve is predominantly used during the starting of the engine at temperatures below  $0^{\circ}\text{C}$  due to the high viscosity of the engine oil.

## 4.4. Piston cooling

Due to the increasing power of the current BMW diesel engines, the pistons are subjected to very high thermal loads. In order to guarantee their operation, they must therefore be cooled.

# B57 Engine

## 4. Oil Supply

The piston ring zone features a coolant duct (ring duct) to enable the heat to be dissipated effectively from the piston crown. Oil spray nozzles supply the underside of the pistons with oil for cooling purposes. It is pointed directly at a bore hole in the piston which leads to the cooling duct. The piston stroke ensures the circulation of the oil and a so-called "shaker effect". The oil vibrates in the duct and with it improves the cooling effect, as more heat can be transferred to the oil. The oil flows through a drain bore back into the crankcase.

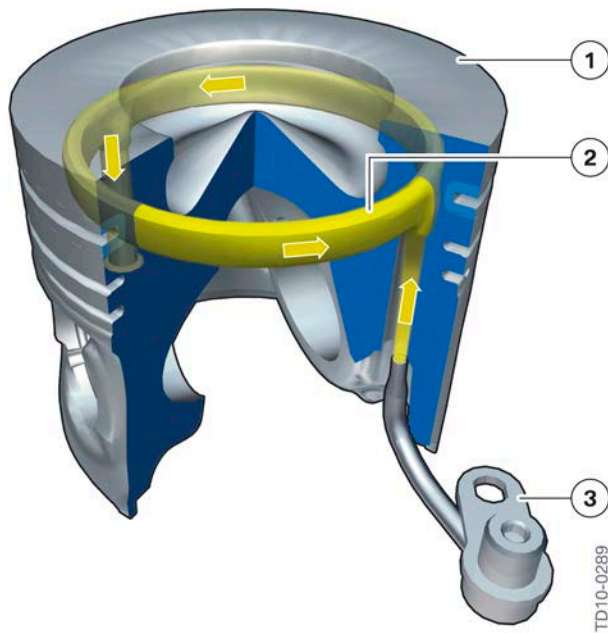

Piston cooling principle

Index	Explanation
1	Piston crown
2	Cooling duct
3	Oil spray nozzle

So far, the cooling has been executed by an oil spray nozzle integrated into the piston cooling valve. The piston cooling valve ensures that the oil spray nozzle only starts working from a pre-defined pressure. There are different reasons for this:

- If the oil pressure were too low, the oil spray would not reach the piston crown anyway.
- If the oil pressure is too low, the system prevents further pressure from being lost through the oil spray nozzles and lubrication points not being reached in the engine.
- When the engine has stopped, the system prevents the oil ducts from running dry via the oil spray nozzles and no oil being applied to the lubrication points during engine starting.

In addition to the bearing positions, the oil pump also supplies the oil spray nozzles with the required volumetric flow, whereby the consumption of the oil spray nozzles significantly influences the power of the oil pump.

For this reason, the B57 engine has centrally controlled piston cooling for the first time. Deactivating the piston cooling reduces the oil pump power. In turn, this reduces the power loss of the engine and saves fuel in the partial load range with the same vehicle performance.



# B57 Engine

## 4. Oil Supply

The centrally controlled piston cooling has the following special features:

- Additional oil ducts in the engine block
- Oil spray nozzles without piston cooling valve
- Central valve
- Oil pressure switch

The central valve replaces the piston cooling valve which was previously integrated in the oil spray nozzle. This enables requirement-based piston cooling over the entire characteristic map range of the engine.

The following system overview provides an initial outline of the structure of the piston cooling in the B57 engine.

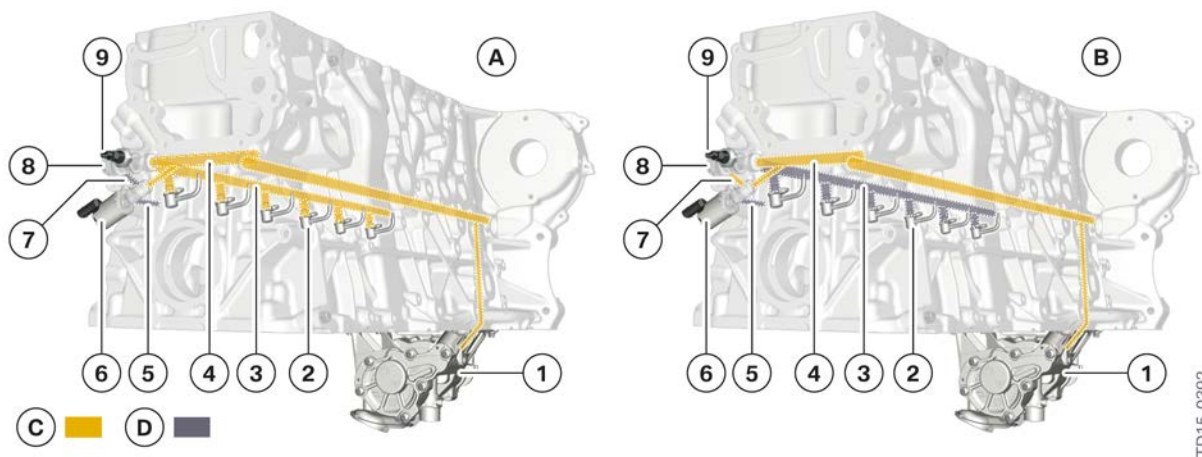

TD15-0392

System overview of the centrally controlled piston cooling, B57 engine

Index	Explanation
A	Piston cooling active (solenoid valve de-energized)
B	Piston cooling not active (solenoid valve supplied with current)
C	Oil pressure
D	Depressurized
1	Oil pump
2	Oil spray nozzle
3	Oil duct to the oil spray nozzles
4	Main oil duct from oil filter
5	Return channel
6	Solenoid valve
7	Control channel
8	Hydraulic valve
9	Oil pressure switch

# B57 Engine

## 4. Oil Supply

The centrally controlled piston cooling implemented in the B57 engine provides the following advantages:

- Targeted deactivation of the piston cooling, independent of the oil pressure
  - Lower drive power of the oil pump
  - Lower fuel consumption
  - Lower exhaust emissions

The following table illustrates the piston cooling differences as regards their use in the N57, B47 and B57 engines:

<b>Engines</b>	<b>Characteristics</b>
N57 Engine	<ul style="list-style-type: none"><li>• Oil spray nozzles with integrated piston cooling valve</li><li>• Piston cooling always active from an oil pressure of 1.2 bar.</li></ul>
B47 Engine	<ul style="list-style-type: none"><li>• Oil spray nozzles with integrated piston cooling valve</li><li>• Piston cooling active from an oil pressure of 1.8 bar</li><li>• The piston cooling can be deactivated via the characteristic map-controlled oil supply. This occurs through the reduction of oil pressure to below the opening pressure of the piston cooling valves.</li></ul>
B57 Engine	<ul style="list-style-type: none"><li>• Oil spray nozzles without piston cooling valve</li><li>• Central valve for the control of piston cooling</li><li>• Piston cooling active from an oil pressure of 1.0 bar</li><li>• Piston cooling can be deactivated as required.</li></ul>

# B57 Engine

## 4. Oil Supply

### 4.4.1. Central valve

The central valve has the function of specifically activating or deactivating the piston cooling and is composed of the following 2 components:

- Solenoid valve
- Hydraulic valve

#### Solenoid valve

The solenoid valve is required to activate the hydraulic valve. Actuation occurs as required via the Digital Diesel Electronics (DDE).

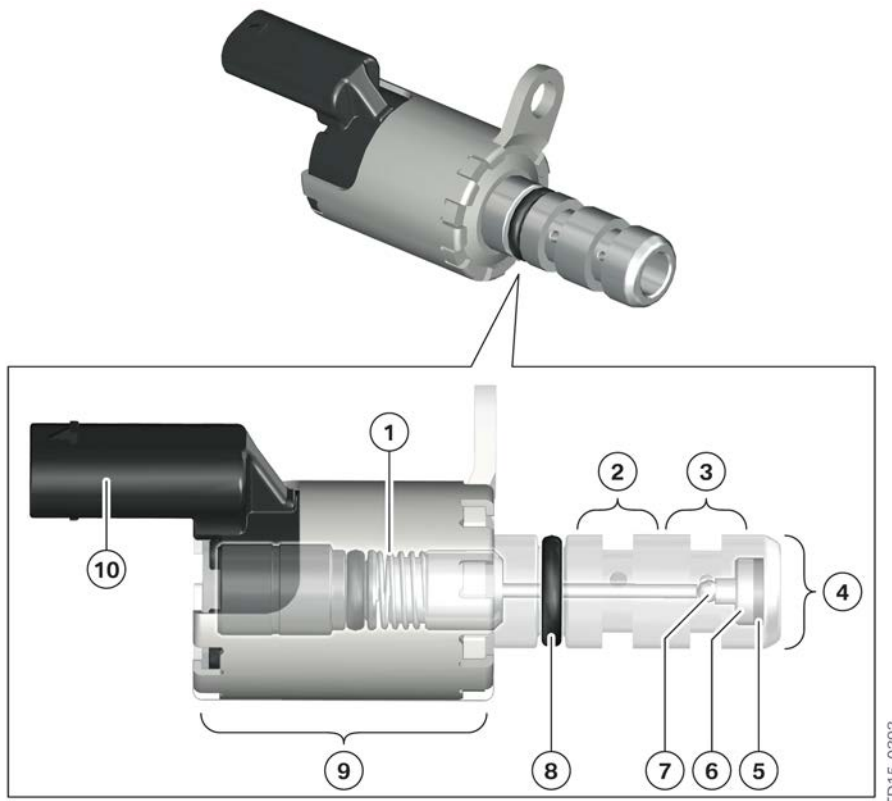

Solenoid valve (central valve), B57 engine

Index	Explanation
1	Compression spring
2	Return channel to the crank space
3	Control channel to the hydraulic valve
4	Main oil duct from oil filter
5	Oil strainer
6	Valve seat

# B57 Engine

## 4. Oil Supply

Index	Explanation
7	Valve ball
8	Sealing ring
9	Solenoid coil
10	Electrical connection

The solenoid valve has the following 2 switching positions:

- Solenoid valve de-energized:
  - Spring force of the compression spring keeps the solenoid valve closed.
  - Return channel is connected to the control channel.
- Solenoid valve is supplied with current by the DDE:
  - Solenoid coil pulls against the spring force.
  - Control channel is opened to the oil from the main oil duct.
  - Return channel is closed by the valve ball.

# B57 Engine

## 4. Oil Supply

### Hydraulic valve

The hydraulic valve is a purely mechanical valve and has the function of activating or deactivating the piston cooling.

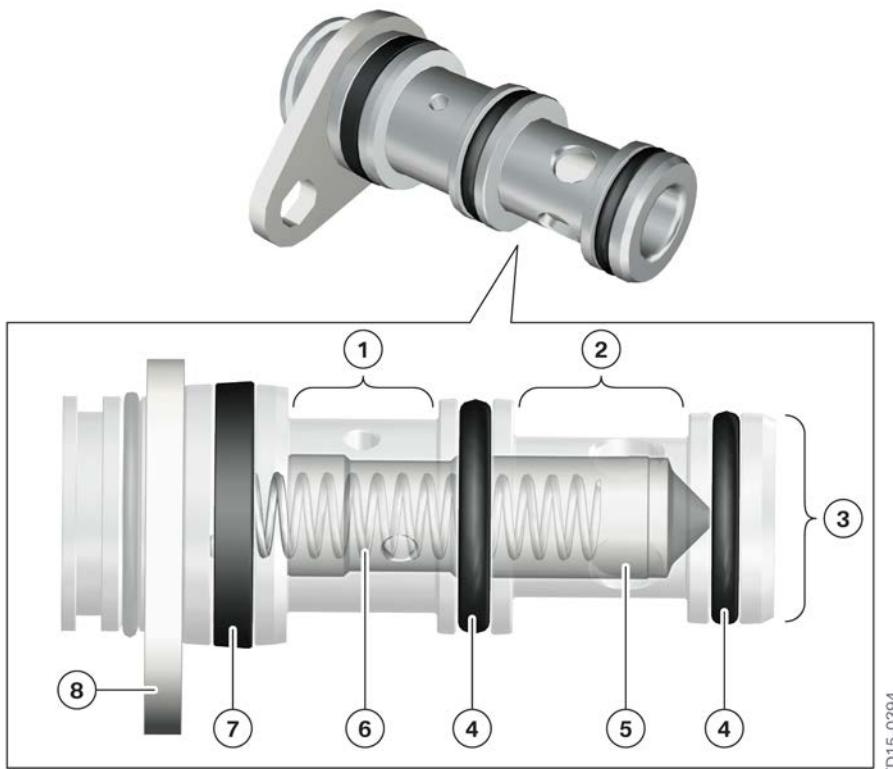

Hydraulic valve (central valve), B57 engine

Index	Explanation
1	Control channel from solenoid valve
2	Oil duct to the oil spray nozzles
3	Main oil duct from oil filter
4	Sealing ring
5	Piston
6	Spring
7	Sealing ring
8	Mounting cap

# B57 Engine

## 4. Oil Supply

The following operating condition opens the hydraulic valve and activates the piston cooling:

- Oil pressure from the main oil duct > 1 bar.
  - Piston is moved against the spring force.
  - Channel to the oil spray nozzles is opened and the pistons are cooled.
  - Oil located behind the piston can drain into the crank space via the control channel, the solenoid valve and the return channel.

The following operating conditions prevent the hydraulic valve from opening and deactivate the piston cooling:

- Oil pressure from the main oil duct < 1 bar.
  - Spring force is greater than the oil pressure from the main oil duct.
  - Channel to the oil spray nozzles is not opened.
- Solenoid valve supplied with current.
  - Oil is directed from the solenoid valve through the control channel behind the pistons of the hydraulic valve.
  - Oil pressure and spring force generate a counterpressure and close the hydraulic valve against the main oil duct.
  - The channel to the oil spray nozzles can no longer be opened.

### Illustration of central valve functions

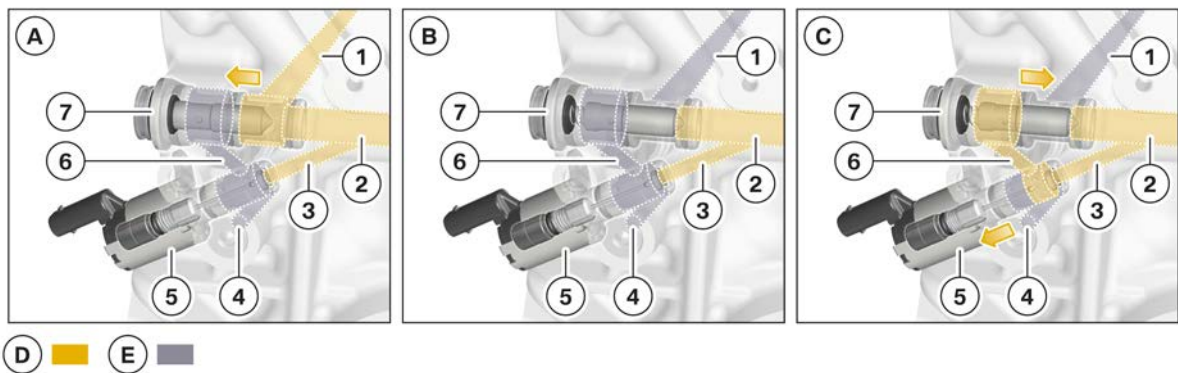

Illustration of central valve functions, B57 engine

Index	Explanation
A	Solenoid valve de-energized, oil pressure in the main oil duct > 1 bar. Piston cooling active.
B	Solenoid valve de-energized, oil pressure in the main oil duct < 1 bar. Piston cooling deactivated.
C	Solenoid valve supplied with current, oil pressure in the main oil duct > 1 bar. Piston cooling deactivated.
D	Oil pressure

# B57 Engine

## 4. Oil Supply

Index	Explanation
E	Depressurized
1	Channel to the oil spray nozzles
2	Main oil duct to the hydraulic valve
3	Main oil duct to the solenoid valve
4	Return channel
5	Solenoid valve
6	Control channel
7	Hydraulic valve

### 4.4.2. Oil spray nozzles

The oil spray nozzles are composed of housing and a pipe through which the oil is precisely sprayed into the piston cooling channel. The oil spray nozzles of the B57 engine do not have any mechanically moving components.

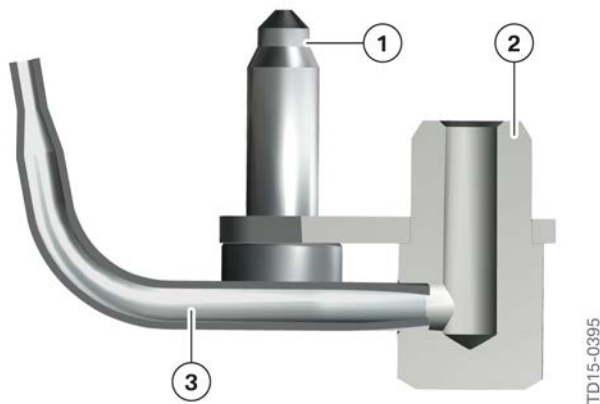

Oil spray nozzle, B57 engine

Index	Explanation
1	Retaining screw
2	Housing
3	Pipe



**In order to achieve an optimum cooling effect, it is essential to position the oil spray nozzles exactly. Non-compliance may lead to damage to the engine. Please observe the current repair instructions.**

# B57 Engine

## 4. Oil Supply

### 4.4.3. Oil pressure switch

The oil pressure switch has the function of monitoring the central valve and is located in the oil duct to the oil spray nozzles. The switching pressure is 0.3 bar – 0.6 bar.

The following information from the oil pressure switch is evaluated by the Digital Diesel Electronics (DDE):

- The oil pressure switch contact is closed.
  - Piston cooling active
- The oil pressure switch contact is open.
  - Piston cooling deactivated

The DDE requires this information for diagnosis in order to monitor the valve positions.

If the DDE receives an implausible signal from the oil pressure switch, the piston cooling can no longer be deactivated.

### 4.4.4. Switching strategy

For oil temperatures  $< 20^{\circ}\text{C}$  ( $68^{\circ}\text{F}$ ) the piston cooling is always active. The cold start is shortened by the transfer of the heat energy from the piston to the engine oil. This has a positive effect on the internal friction and therefore on the exhaust emissions and fuel consumption.

The centrally controlled piston cooling is deactivated in the partial load range at oil temperatures  $\geq 20^{\circ}\text{C}$  ( $68^{\circ}\text{F}$ ). In these engine speed ranges, the exhaust-gas recirculation rate is increased to lower the nitrogen oxide emissions. Due to the resulting cooler combustion, the combustion chamber and the piston crown cool down. For this reason, piston cooling is not required in these operating ranges and is specifically deactivated.

The following engine operating values also influence the switching strategy of the piston cooling:

- Engine speed
- Fuel injection rate



# B57 Engine

## 4. Oil Supply

### 4.5. Oil filter module

The oil filter module used in the B57 engine is also a part of the modular design principle. The module is therefore used here once again.

Due to the installation space, the filter is arranged upright in the area of the 5th cylinder near the bulkhead. To screw the oil filter module to the crankcase, screws are used which cannot be lost.

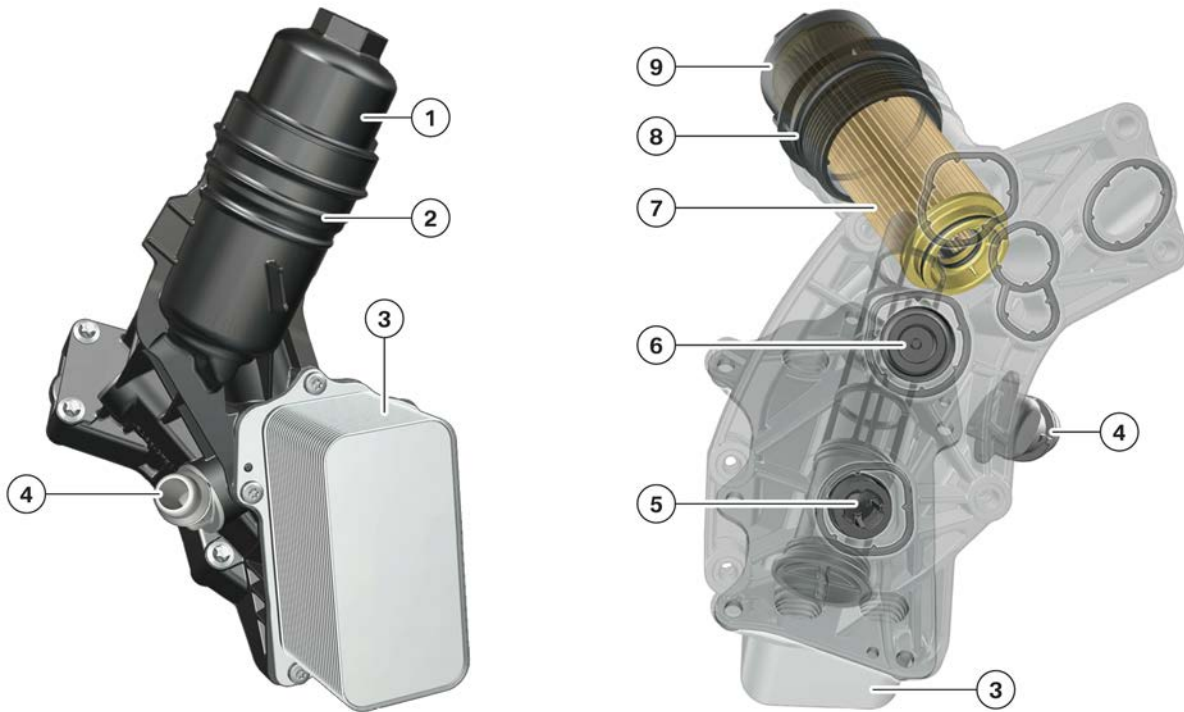

TD15-0400

B57 engine oil filter module

Index	Explanation
1	Oil filter cover
2	Oil filter housing
3	Engine oil-to-coolant heat exchanger
4	Coolant return to the secondary thermostat
5	Non-return valve
6	Heat exchanger bypass valve
7	Oil filter element
8	Oil filter cover sealing ring
9	Filter bypass valve (integrated into the oil filter cover)

# B57 Engine

## 4. Oil Supply

### 4.5.1. Discharge valve

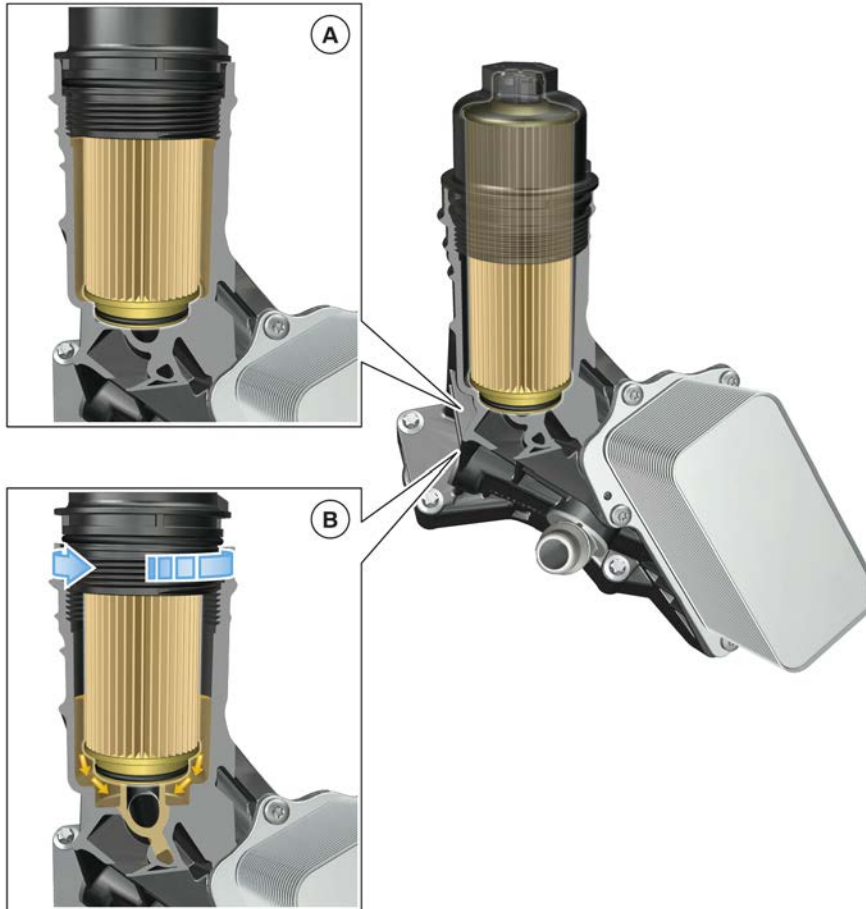

TD15-0401

Discharge valve, B57 engine

Index	Explanation
A	Oil filter cover, closed
B	Oil filter cover, loosened

When the oil filter is changed, the oil flows via the discharge valve into a return duct and back to the oil sump. A sealing ring is integrated below on the oil filter element which provides a seal against the oil filter housing. The return channel is therefore sealed when the oil filter cover is closed.

When the oil filter cover is loosened, after about 2 turns the O-ring integrated into the oil filter element opens the return channel to the oil sump. This means that during servicing, the full oil filter can be drained before opening the oil filter cover completely.

The oil filter element and cover sealing ring are contained in the oil filter service kit.

# B57 Engine

## 5. Cooling System

The cooling system serves to protect the engine components such as cylinder head and crankcase from overheating. Furthermore, the cooling system saves the engine oil and transmission oil from excessive temperatures.

In addition to the engine cooling function, the B57 engine also has a warm-up function. Using the vacuum controlled coolant pump, the cooling can be switched off for everything except the necessary cooling of the exhaust-gas recirculation. Through this, the heat generated from the EGR cooling is used for efficient heating of the engine oil, resulting in faster heating at the places subject to friction and therefore to an advantage in terms of consumption.

The secondary thermostat was introduced in order to switch between the warm-up function and efficient engine oil cooling. During warm-up, the secondary thermostat enables the transfer of heat from the EGR cooling to the engine oil, and during cooling, ensures that the hot coolant from the engine oil cooler is directed via the radiator.

### 5.1. Cooling circuit

#### 5.1.1. System overview

The system overview illustrates the coolant circuit of the B57 engine in the upper and top performance class. Depending on the vehicle and engine variant, the cooling system is equipped with various components.

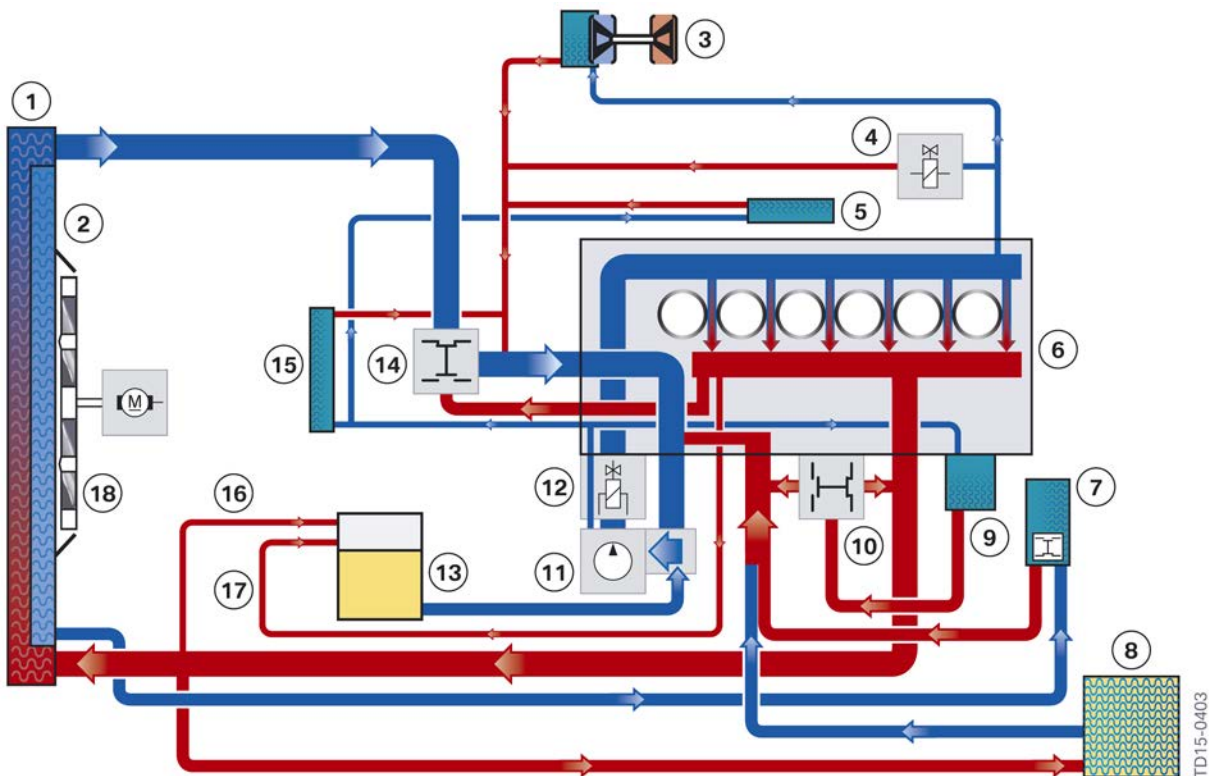

Coolant system circuit diagram, B57 engine

# B57 Engine

## 5. Cooling System

Index	Explanation
1	Radiator (high temperature range)
2	Radiator (low temperature range)
3	Cooled compressor of the low pressure exhaust turbocharger (only B57D30T0 — Not for US)
4	SCR metering module
5	Low pressure exhaust-gas recirculation cooler
6	Engine housing
7	Transmission fluid-to-coolant heat exchanger (automatic transmission only)
8	Heat exchanger
9	Engine oil-to-coolant heat exchanger
10	Secondary thermostat
11	Coolant pump
12	Shift element
13	Expansion tank
14	Primary thermostat
15	High pressure exhaust-gas recirculation cooler
16	Coolant ventilation line
17	Coolant ventilation line from cylinder head
18	Electric fan

### 5.1.2. Cooling module

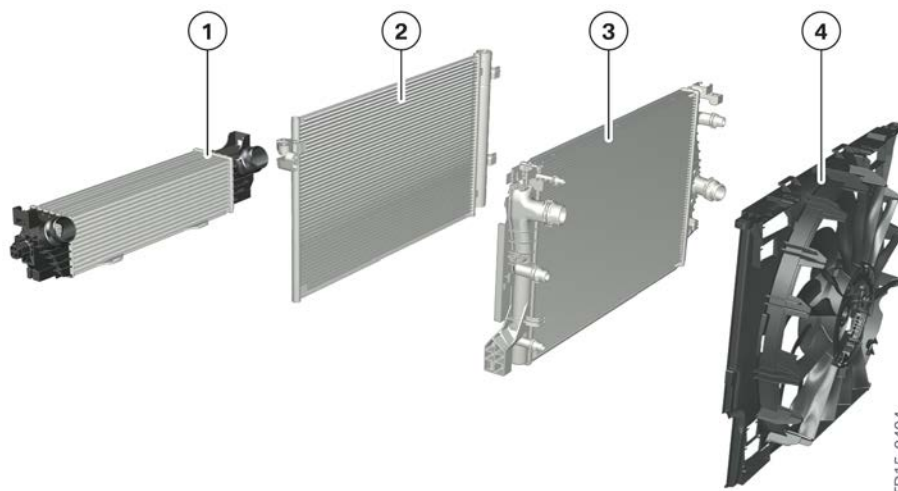

Cooling module in the BMW G30 with B57 engine

TD15-0404

# B57 Engine

## 5. Cooling System

Index	Explanation
1	Charge air cooler
2	A/C condenser
3	Radiator
4	Electric fan

### 5.2. Coolant pump

The coolant pump impeller draws in coolant at the transfer point of the cylinder crankcase and directs it into the pressure chamber.

In order to further lower the fuel consumption and the exhaust emissions in the warm-up phase, a vacuum controlled coolant pump is used in the B57 engine. The shift element is connected via a linkage to the vacuum unit. An electric changeover valve switches the vacuum and controls the shift element. This allows the coolant flow to the engine block to be switched off during the warm-up phase. The coolant pump is integrated into the component carrier and can be replaced separately.

The component carrier is also designed as a holder for the following components:

- Exhaust-gas recirculation cooler
- Alternator
- A/C compressor

# B57 Engine

## 5. Cooling System

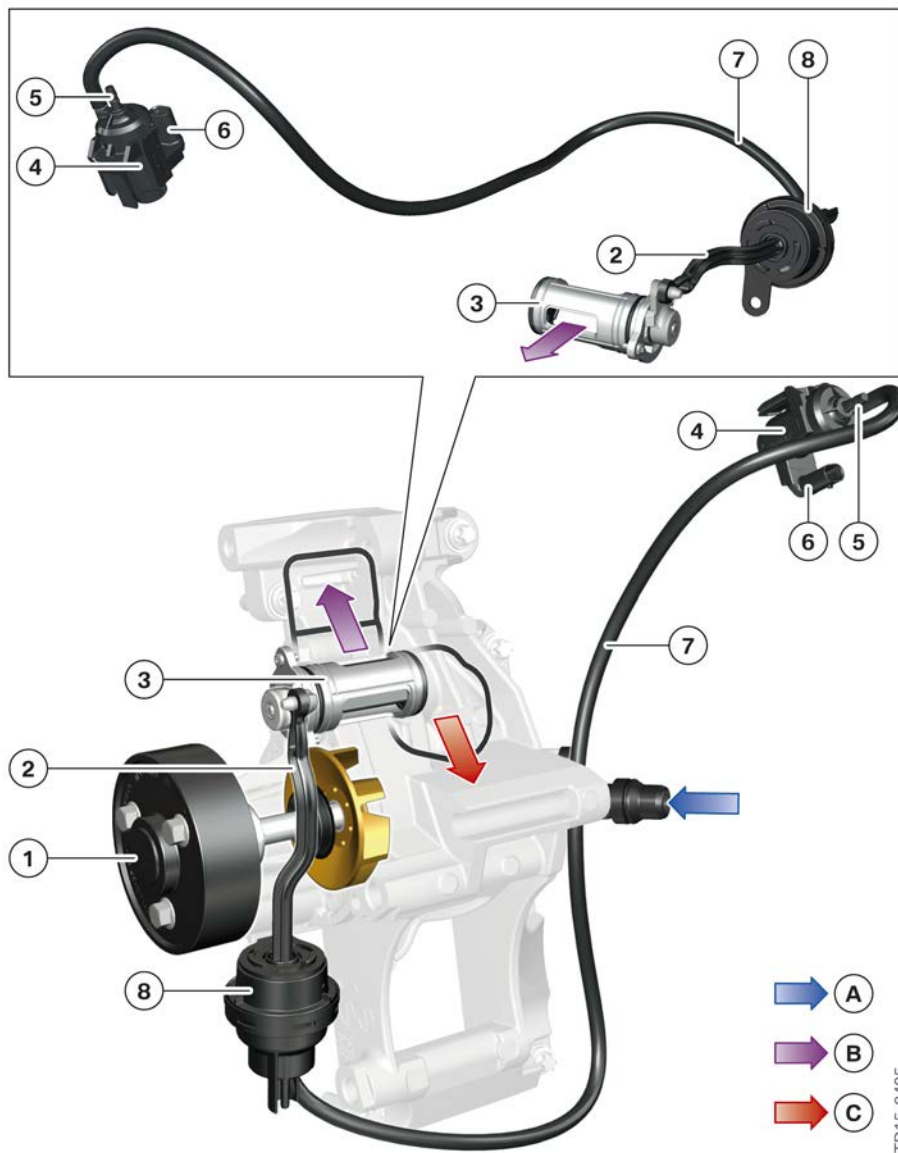

Vacuum controlled coolant pump in the B57 engine

Index	Explanation
A	Cold coolant
B	Warm coolant
C	Hot coolant
1	Belt pulley
2	Gearshift rod
3	Shift element
4	Electric changeover valve

# B57 Engine

## 5. Cooling System

Index	Explanation
5	Vacuum connection
6	Electrical connection
7	Vacuum line
8	Vacuum unit

### 5.2.1. Shift element open

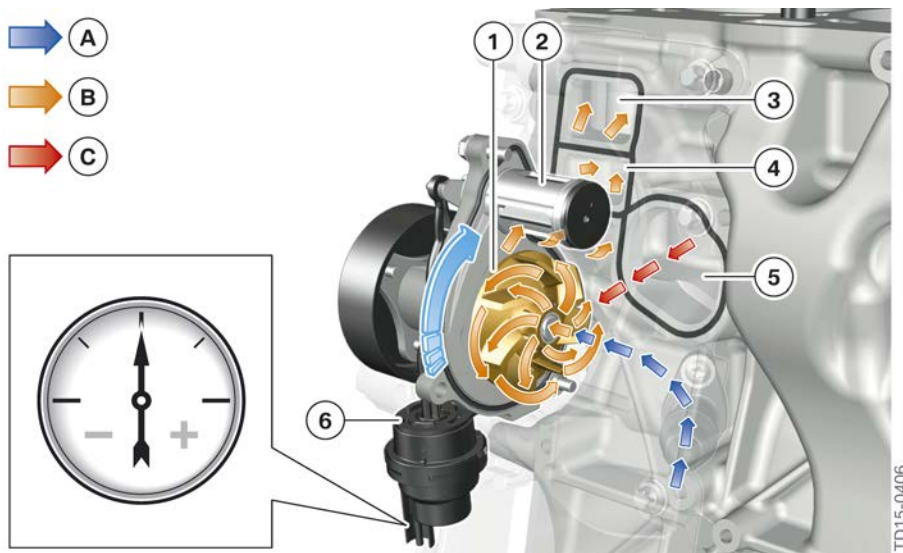

Shift element of coolant pump open

Index	Explanation
A	Cold coolant
B	Warm coolant
C	Hot coolant
1	Impeller
2	Shift element
3	Coolant duct to cylinder crankcase
4	Coolant duct to the exhaust-gas recirculation coolers and the engine oil-to-coolant heat exchanger
5	Coolant pump intake port
6	Vacuum unit

As long as the Digital Diesel Electronics (DDE) does not activate the electric changeover valve, the shift element is open. In this state the cooling circuit is identical to vehicles without a vacuum controlled coolant pump.

# B57 Engine

## 5. Cooling System

### 5.2.2. Shift element closed, warm-up function

During the cold start and in the warm-up phase, the high internal engine friction has a negative impact on exhaust emissions and fuel consumption. Therefore the warm-up function is used to shorten this period. The warm-up function is comprised of the following components:

- Vacuum controlled coolant pump
- Modified coolant supply in the cylinder crankcase
- Oil filter module
- Secondary thermostat

In the warm-up phase, the radiator is separated from the cooling system by the primary thermostat. The coolant pump pumps the coolant through the small coolant circuit (bypass). In order to bring the engine up to operating temperature more quickly, the vacuum shift element for the pump is closed and the engine block is disconnected from the coolant pump. The coolant no longer circulates through the block but remains still. Due to this, the coolant is heated much faster and the warm-up phase of the engine shortened.

The coolant circuit to the high and low-pressure exhaust-gas recirculation coolers however cannot be closed. The cooling of the recirculated exhaust gases increases the efficiency of the EGR system. The heated coolant is delivered to the engine oil-to-coolant heat exchanger via a coolant duct integrated into the crankcase. The heat is transferred from the coolant to the oil and the internal engine friction therefore reduced. The coolant returns via the secondary thermostat to the inlet port of the coolant pump.



# B57 Engine

## 5. Cooling System

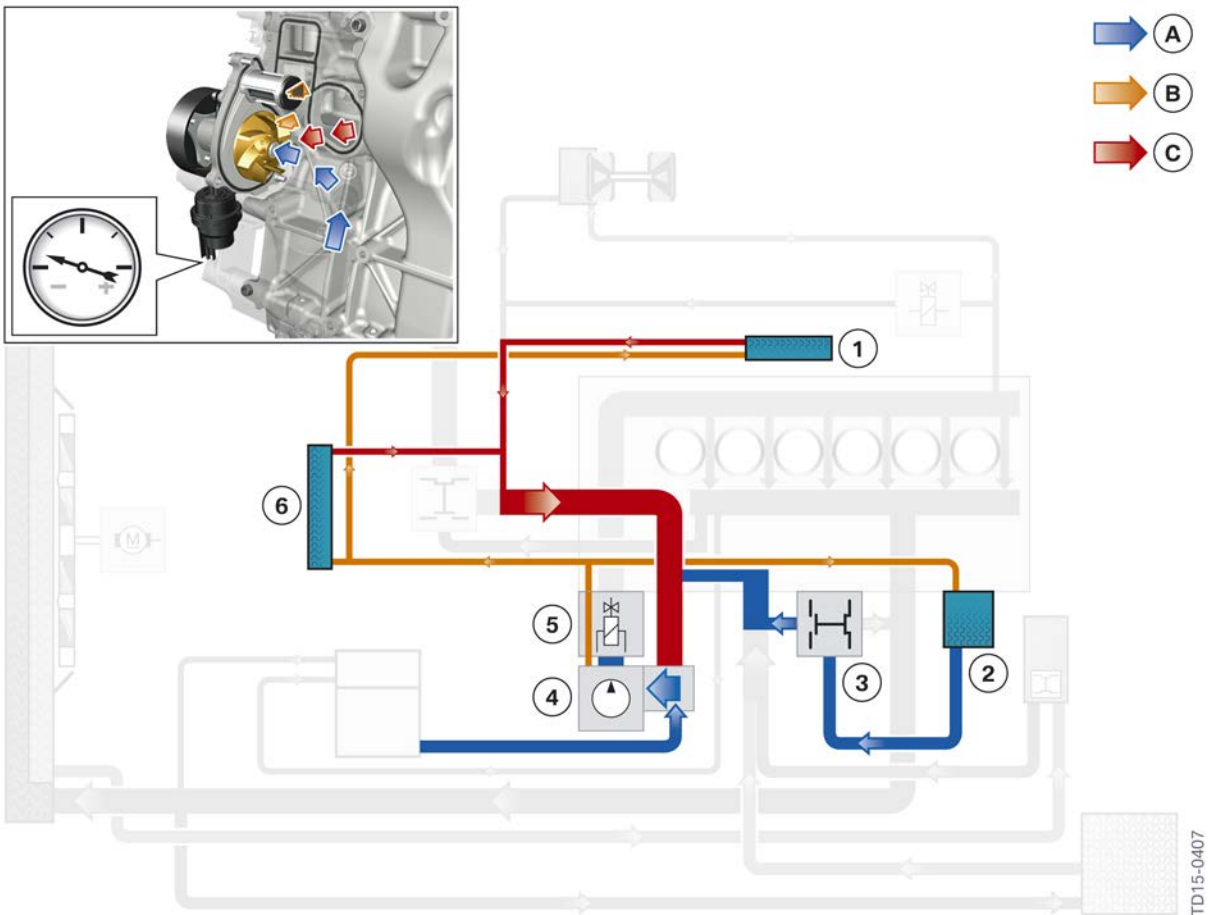

Shift element of coolant pump closed

Index	Explanation
A	Cold coolant
B	Warm coolant
C	Hot coolant
1	Low-pressure exhaust-gas recirculation cooler
2	Engine oil-to-coolant heat exchanger
3	Secondary thermostat
4	Coolant pump
5	Shift element
6	High-pressure exhaust-gas recirculation cooler

The shortened warm-up phase results in the following advantages:

- Reduced fuel consumption
- Reduced exhaust emissions

# B57 Engine

## 5. Cooling System

In the event of a leak in the vacuum system, as well as a failure of the electric vacuum changeover valve, the coolant circuit can no longer be interrupted. In this case the cooling circuit is only adjusted via the thermostat.

A plausibility check determines whether the shift element of the coolant pump is actually closed. For this, the DDE compares the following values from the coolant temperature sensor:

- Coolant temperature for switching operation  $T_1$
- Actual coolant temperature  $T_2$

If the shift element is closed, the coolant in the engine block is warmed by the engine operation. This results in a lower density of the coolant and the heated coolant rises up into the cylinder head. The DDE recognizes a temperature difference between  $T_1$  and  $T_2$  via the coolant temperature sensor reading, which increases within a pre-defined time.

If the shift element cannot be closed due to a fault, the coolant pump circulates the heated coolant in the bypass. As the heat is distributed so evenly, the Digital Diesel Electronics recognizes a more slowly increasing temperature difference between  $T_1$  and  $T_2$  at the coolant temperature sensor.

If a fault is detected, the DDE saves a fault code entry in the information memory.

### 5.3. Coolant thermostat

#### 5.3.1. Primary coolant thermostat

The B57 engine adjusts the coolant temperature via a conventional thermostat. In other words, exclusively the coolant temperature determines the regulation. This is performed by a wax element which records the temperature of the coolant. The wax functions as an expanding material which expands when heated and thereby opens the thermostat. This ensures coolant flow distribution either through the radiator or around it through the bypass. The thermostat begins to open at a coolant temperature of 88° C (190° F) and is completely open at 120° C (240° F).

With this control, maximum cooling is ensured at high coolant temperatures, while at very low temperatures cooling can be avoided to a large extent.

# B57 Engine

## 5. Cooling System

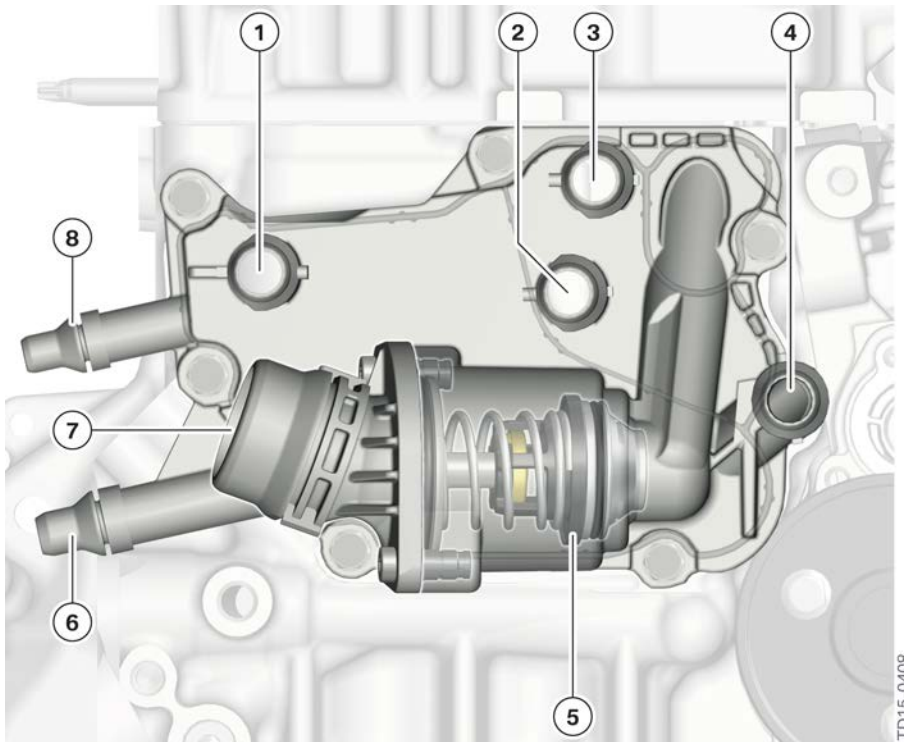

Primary coolant thermostat, B57 engine

Index	Explanation
1	Coolant return, low-pressure exhaust-gas recirculation
2	Coolant supply to high-pressure exhaust-gas recirculation
3	Coolant supply to low-pressure exhaust-gas recirculation
4	Coolant return, high-pressure exhaust-gas recirculation
5	Coolant thermostat
6	Coolant return from compressor housing of low-pressure stage (only B57D30T0, Not for US)
7	Connection, coolant hose to radiator
8	Coolant return from SCR metering module

The primary thermostat also serves as a coolant distributor and a coolant manifold of the ancillary components that are cooled by water.

# B57 Engine

## 5. Cooling System

### 5.3.2. Secondary coolant thermostat

The secondary thermostat controls the return flow of the coolant from the engine oil-to-coolant heat exchanger. The secondary thermostat divides the return flow of the coolant depending on the temperature:

- Up to 105° C (221° F) the thermostat is closed and the coolant only flows to the inlet side of the coolant pump.
- Between 105° C (221° F) and 110° C (230° F) the thermostat opens. Depending on the opening of the thermostat, the coolant flows back to the coolant pump and to the radiator.
- The thermostat is completely open above 110° C (230° F) and the coolant only flows back to the radiator.

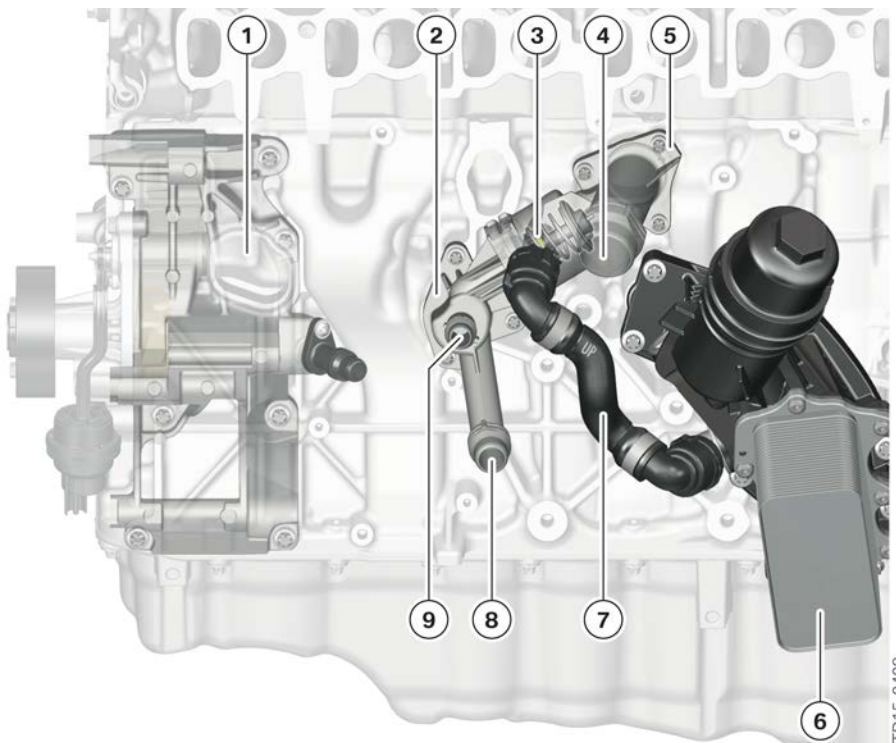

Secondary coolant thermostat, B57 engine

Index	Explanation
1	Intake side of the coolant pump
2	Connecting flange to the intake side of the coolant pump
3	Coolant thermostat
4	Connection of coolant hose to radiator
5	Connecting flange, coolant supply to the radiator

# B57 Engine

## 5. Cooling System

Index	Explanation
6	Engine oil-to-coolant heat exchanger
7	Coolant hose from the engine oil-to-coolant heat exchanger to the secondary thermostat
8	Coolant return from the heat exchanger for the heating system
9	Coolant return from transmission oil-to-coolant heat exchanger

Another function of the secondary thermostat is to collect the coolant from the heating system heater core and the transmission oil-to-coolant heat exchanger and directly feed it to the coolant pump.

As with the primary thermostat, a wax expansion element is used in the secondary thermostat which expands during heating and opens the thermostat in the process.

### 5.4. Transmission oil cooling

A transmission oil-to-coolant heat exchanger is used for vehicles with automatic transmission. This is a common part used in the B58 engine. The cooling module is mounted on the intake side in the area of the last cylinder.

If the temperature of the transmission oil increases to  $\geq 87^{\circ}\text{C}$  ( $188.6^{\circ}\text{F}$ ), the thermostat opens. The flow of coolant from the low-temperature cooling unit via the transmission oil-to-coolant heat exchanger is enabled.

### 5.5. Coolant

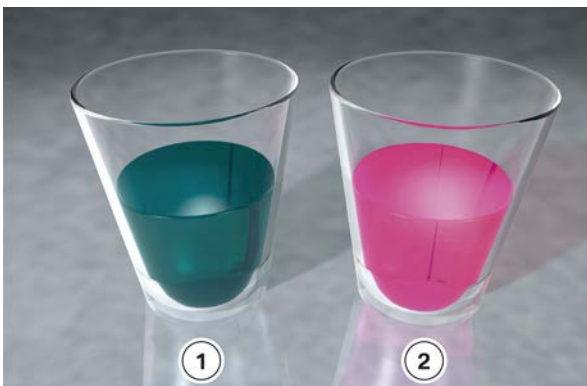

Coolant

Index	Explanation
1	Silicate-based coolant
2	Amino acid-based coolant

# B57 Engine

## 5. Cooling System

A silicate-based coolant is used for all the BMW Group vehicles. This coolant can be recognized by its blue/green color. The silicate-based coolant forms a protective layer of silicate compounds on the surfaces of the components. The formation of this protective layer only occurs with new coolant. If components (e.g. coolant pump, thermostat, cylinder head gasket etc.) are replaced, the coolant must always be changed to ensure the formation of a new protective layer.

Amino acid-based coolant is also used in the industry and can be recognized by its pink color. With the coolant based on amino acids, the component surface is corroded, generating a protective oxide layer.



---

**Caution!!! If the silicate-based coolant is mixed with the amino-acid-based coolant, the mixture loses its corrosion protection mechanism and turns a brown color.**

---

### 5.5.1. Cooling system bleeding

The cooling system must be bled following repair work. Due to the use of a vacuum controlled coolant pump, a cooling system bleeding routine must also be initiated where targeted activation of the shift element is achieved.

The following prerequisites are necessary:

- Automatic transmission: Gear selector switch in position N or P
- Manual gearbox: In neutral and clutch not engaged
- Coolant temperature at the start of the cooling system bleeding routine < 50° C (120° F).

It is essential that the following procedure is followed:

- Switch on ignition.
- Set cabin heating to maximum temperature, set blowers to lowest setting.
- Depress accelerator pedal for 10 s as far as it will go.
- Then start the engine and allow to run at idle.
- Shift element in the coolant pump is activated.
- Constantly top up coolant.
- After 5 minutes of idle time:
  - Press 5 times on accelerator up to about 2000 rpm.
  - Run idle for 10 s.
  - Press 5 times on accelerator up to about 2000 rpm.
  - Run idle for 10 s.
- After a further 5 minutes of idle time:
  - Press 5 times on accelerator up to about 2000 rpm.
  - Run idle for 10 s.
  - Press 5 times on accelerator up to about 2000 rpm.
  - Run idle for 10 s.

# B57 Engine

## 5. Cooling System

- 10 minutes after starting the engine, the cooling system bleeding routine is completed.
- Top up the coolant to maximum.



---

**When bleeding the cooling system, please observe the repair instructions. Incorrect bleeding of the cooling system may cause damage to the engine.**

---

# B57 Engine

## 6. Intake Air and Exhaust System

### 6.1. System overview

#### 6.1.1. B57D3000

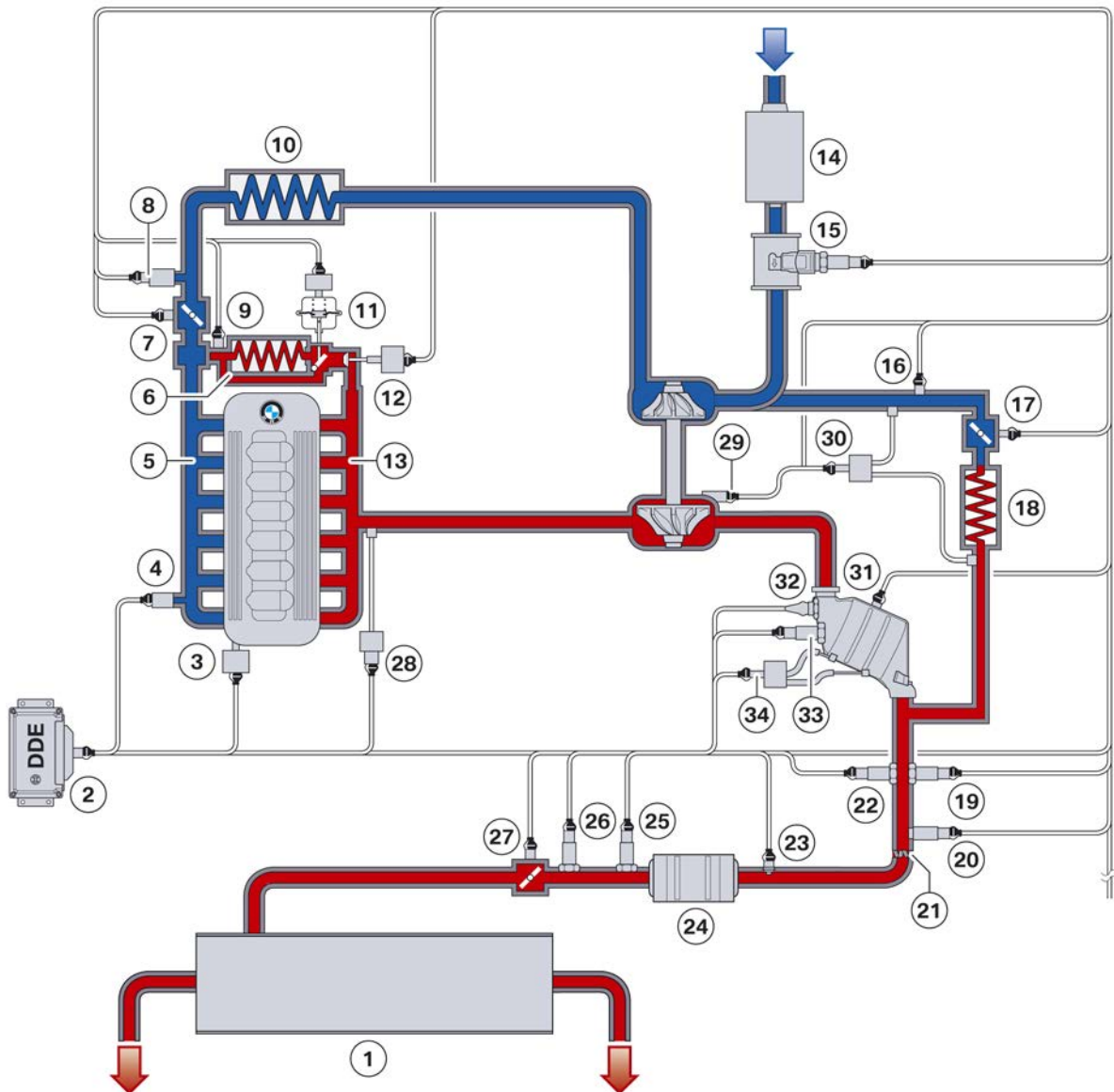

Intake air and exhaust emission system overview, B57D3000

TD14-1701

Index	Explanation
1	Rear silencer
2	Digital Diesel Electronics (DDE) control unit
3	Swirl-flap actuator
4	Charging pressure sensor



# B57 Engine

## 6. Intake Air and Exhaust System

Index	Explanation
5	Intake manifold
6	High-pressure exhaust-gas recirculation cooler
7	Throttle valve
8	Charge-air temperature sensor
9	Exhaust temperature sensor (downstream of high-pressure exhaust-gas recirculation cooler)
10	Charge air cooler
11	Bypass flap, high-pressure exhaust-gas recirculation
12	High-pressure exhaust-gas recirculation valve
13	Exhaust manifold
14	Intake silencer
15	Hot film air mass meter
16	Exhaust temperature sensor (downstream of low-pressure exhaust-gas recirculation cooler)
17	Low-pressure exhaust-gas recirculation valve
18	Low-pressure exhaust-gas recirculation cooler
19	Broadband oxygen sensor downstream of diesel particulate filter (LSU 5.1)
20	SCR metering module
21	SCR mixer
22	NO <sub>x</sub> sensor (before the SCR catalytic converter)
23	Exhaust temperature sensor (upstream of SCR catalytic converter)
24	SCR catalytic converter
25	Diesel particulate sensor (only US version)
26	NO <sub>x</sub> sensor (after SCR catalytic converter)
27	Exhaust gas restriction flap
28	Exhaust back-pressure sensor (upstream of exhaust turbocharger)
29	Electrical variable turbine geometry controller
30	Differential pressure sensor for the low-pressure exhaust-gas recirculation module
31	Exhaust-gas temperature sensor (downstream of catalytic converter)
32	Exhaust temperature sensor (upstream of catalytic converter)
33	Broadband oxygen sensor upstream of diesel particulate filter (LSU 5.1)
34	Differential pressure sensor for diesel particulate filter

# B57 Engine

## 6. Intake Air and Exhaust System

### 6.2. Intake air system

#### 6.2.1. Air duct overview

The untreated intake air reaches the intake silencer with air filter element via the untreated air line with intake air grille. Here, the untreated air is cleaned by the air filter. The clean air is directed from the intake silencer via the hot film air mass meter and the clean air pipe with resonator to the exhaust turbocharger.

The additional volume of the resonator causes a reduction in low-frequency noises in the air intake system. These low-frequency noises arise during acceleration and deceleration of the air column.

The blow-by gases are fed into the clean air pipe. The clean air is compressed in the exhaust turbocharger. The compressed, warm charge air is forwarded to the charge air cooler via a charge air hose. From the charge air cooler the now cooled charge air is directed to the throttle valve via an additional charge air hose and the adapter pipe with temperature sensor. The cooled charge air flows to the intake system via the throttle valve.

# B57 Engine

## 6. Intake Air and Exhaust System

Air intake duct of the B57D3000 in BMW G30

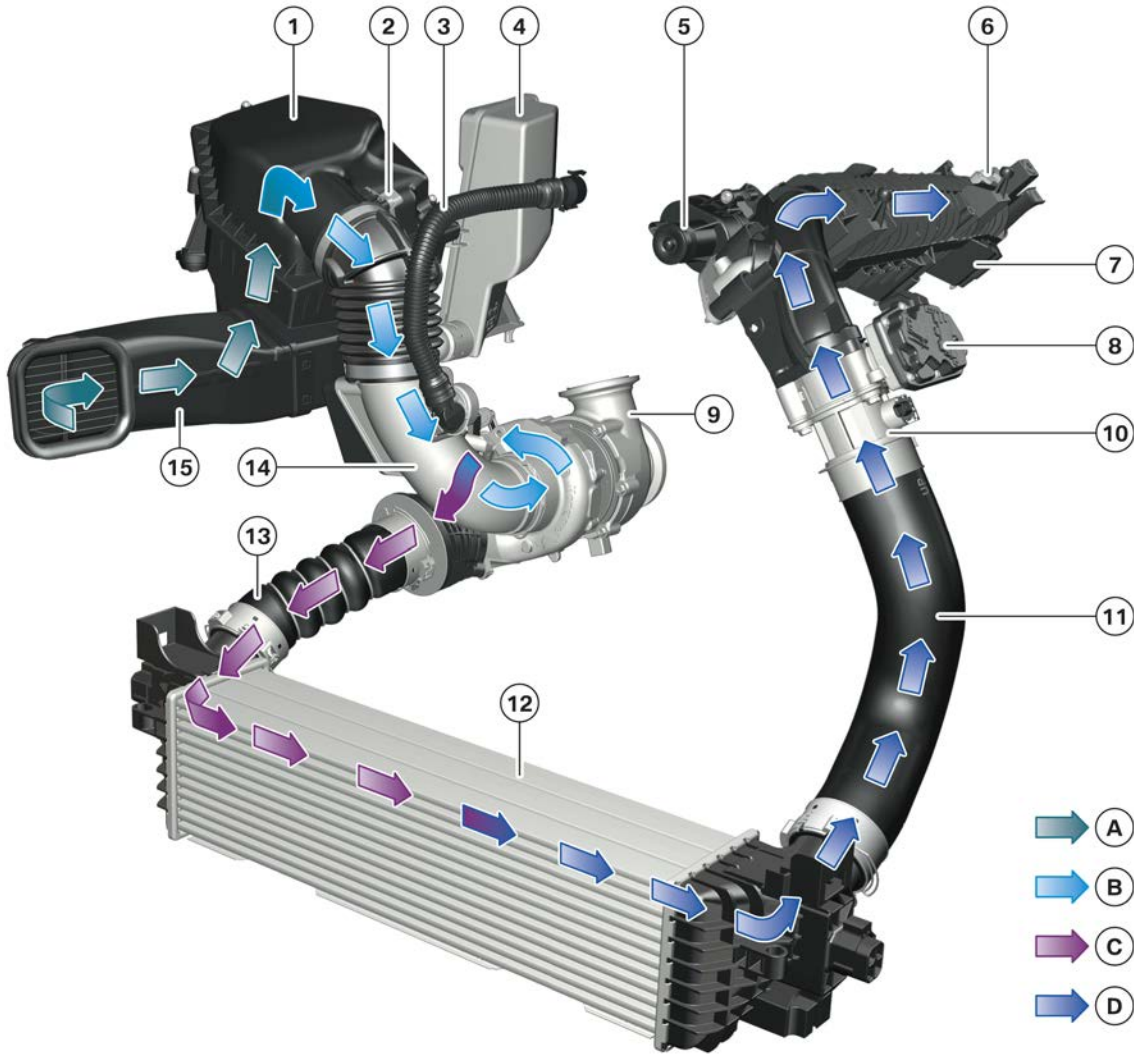

TD15-0415

Air intake duct of B57D3000 in BMW G30

Index	Explanation
A	Fresh air
B	Purified air
C	Heated charge air
D	Cooled charge air
1	Intake silencer with air filter
2	Hot film air mass meter
3	Blow-by gas pipe
4	Resonator
5	Electrical swirl-flap controller with path feedback

# B57 Engine

## 6. Intake Air and Exhaust System

Index	Explanation
6	Charging pressure sensor
7	Intake manifold
8	Electromotive throttle controller with path feedback
9	Exhaust turbocharger
10	Adaptor pipe with charge-air temperature sensor
11	Charge air hose
12	Charge air cooler
13	Resonator with charge air hose
14	Clean air pipe with resonator
15	Untreated air line with intake air grill

### 6.2.2. Charge air cooler

Because the air heats up during compression in the exhaust turbocharger and thus expands, the amount of oxygen which can be routed into the combustion chamber is reduced again. This effect is counteracted in the charge air cooler by cooling the compressed air to increase its density and therefore the oxygen content per volume. The charge air cooler is designed as an air to air heat exchanger and it is located in the cooling module under the radiator. The compressed air flows through the charge air cooler in several plates, around which cooling air flows.

### 6.2.3. Throttle valve

The B57 engine requires a throttle valve for the following functions:

- Throttling of the intake air during the diesel particulate filter regeneration.
- Throttling of the intake air during the exhaust-gas recirculation.
- When the engine stops, the throttle valve is closed in order to prevent shuddering when the engine is switched off.
- Closing of the air intake system to prevent the engine revving up. If the DDE recognizes that the engine is revving up without increasing the fuel quantity, the throttle valve closes to limit the engine speed.

# B57 Engine

## 6. Intake Air and Exhaust System

### 6.3. Exhaust turbocharger

The low-pressure exhaust-gas recirculation presents the exhaust turbocharger with unique challenges. Although the recirculated exhaust gas is fed through the low-pressure exhaust-gas recirculation cooler, there are increased compressor intake temperatures. In operating points with low-pressure exhaust-gas recirculation, the compressor delivers a higher volumetric flow. The higher level of work for the compressor with correspondingly high compressor outlet temperatures results in high thermal loads. Furthermore, the impeller must be protected from the exhaust gases and the particles contained within them.

For this reason, the impellers, which are made of milled aluminium, have been coated with phosphorus-nickel.

#### 6.3.1. Charging pressure control

##### Accumulation of set-point value for charging pressure

The operating characteristics of an exhaust turbocharger can be described in a characteristic map, which is defined via the charging pressure and air flow rate. The following factors limit the operating characteristics of an exhaust turbocharger:

- Maximum compressor speed
- Choke limit
- Pump limit

The choke limit is reached if the velocity of sound is reached at the compressor inlet as a result of a very low cross-section and a further increase in the air flow rate is thus no longer possible.

The pump limit is reached if the flow eases as a result of a very low volumetric flow and excessive pressure ratios of the compressor guide vanes and the already compressed air flows back through the exhaust turbocharger. This behavior causes extreme noise emissions, ("pumping") and high component stress.

The aim in the accumulation of the set-point value is not to exceed these operating limits through a suitable design and programming of the DDE.

##### Model-based charging pressure control

The charging pressure control is executed by a model-based pre-control (MBC = Model Based Boost Control). This means that all criteria for the most efficient and dynamic build-up of charging pressure possible are calculated in a complex calculation model. The required control values are thus forwarded on to the charging pressure controllers quickly and directly.

Furthermore, in this model, all operating and ambient conditions are taken into consideration, meaning that correction characteristic maps in the DDE can be omitted. Charging pressure control deviations are recognized by the DDE immediately and adjusted.

# B57 Engine

## 6. Intake Air and Exhaust System

### 6.3.2. Exhaust turbochargers B57D3000

In the upper performance class B57 engine has a variable turbine geometry exhaust turbocharger with plain bearing.

The supply with oil is guaranteed via the oil circuit of the engine. With sufficient oil supply the exhaust turbocharger shaft floats on the oil film and is thus positioned wear-free.

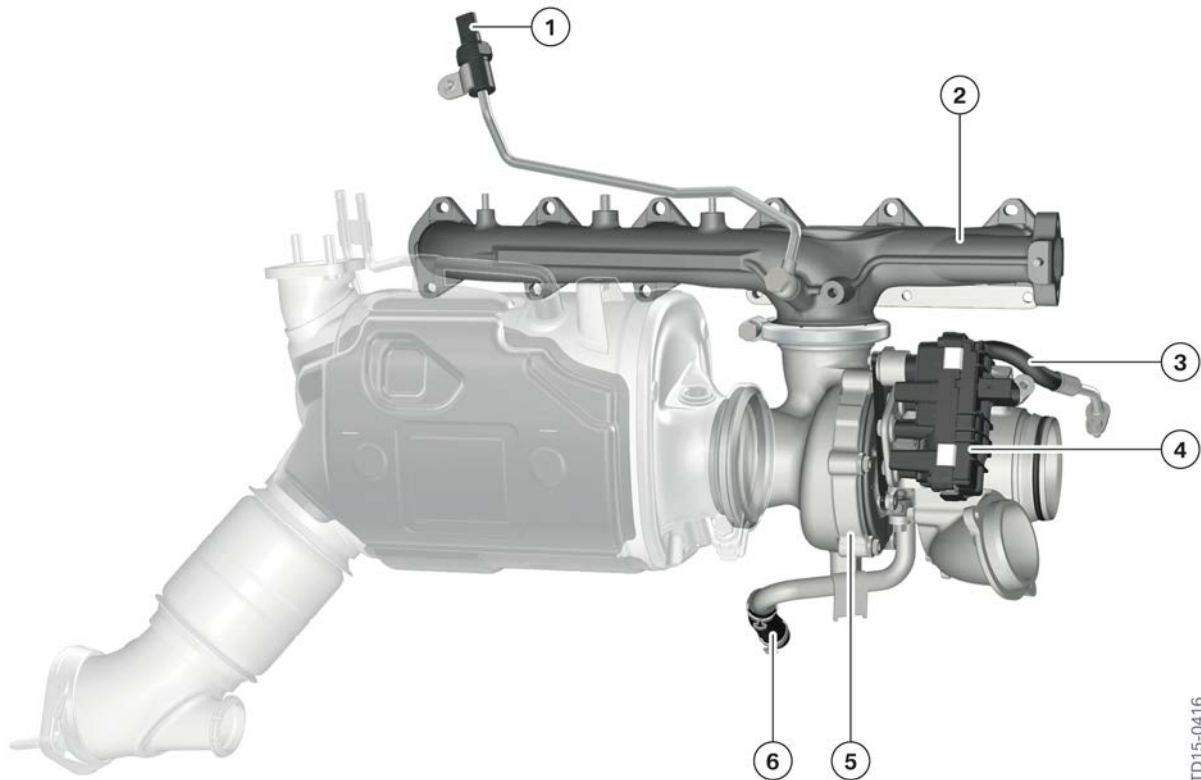

Exhaust turbochargers B57D3000

TD15-0416

Index	Explanation
1	Exhaust back-pressure sensor
2	Exhaust manifold
3	Oil feed line
4	Electrical variable turbine geometry controller
5	Variable turbine geometry exhaust turbocharger
6	Oil return line

The adaptations to the engine concept include the following:

- Revision of the turbine guide vane geometry, as well as of the turbine wheel.
- Revised electrical charging pressure controller.

# B57 Engine

## 6. Intake Air and Exhaust System

Advantages of the adaptations:

- Higher pump limit
- Improved turbine efficiency
  - Advantages to consumption in the partial load range
  - Higher torque available in the full load range
- More precise and quicker adjustment of the guide vanes

### 6.4. Exhaust re-treatment

The following table provides an overview of the emission limits for passenger cars with diesel engines.

With the introduction of EURO 5 b, a new mass measuring method was introduced. This also meant the stipulation of the maximum permissible particulate number.

	<b>EURO 5 a</b>	<b>EURO 5 b</b>	<b>EURO 6</b>
Type test	from 1.09.2009	from 1.09.2011	from 1.09.2014
First registration	from 1.01.2011	from 1.01.2013	from 1.09.2015
CO [mg/km]	500	500	500
HC+NO <sub>x</sub> [mg/km]	230	230	170
NO <sub>x</sub> [mg/km]	180	180	80
PM* [mg/km]	5	4.5	4.5
PN* [1/km]	-	6 x 10 <sup>11</sup>	6 x 10 <sup>11</sup>

PM\* = particle matter (fine dust)

PN\* = particle number

# B57 Engine

## 6. Intake Air and Exhaust System

The following graphic illustrates the exhaust emission system of the B57 engines in the BMW G30 with the EURO 6 exhaust emission standard.

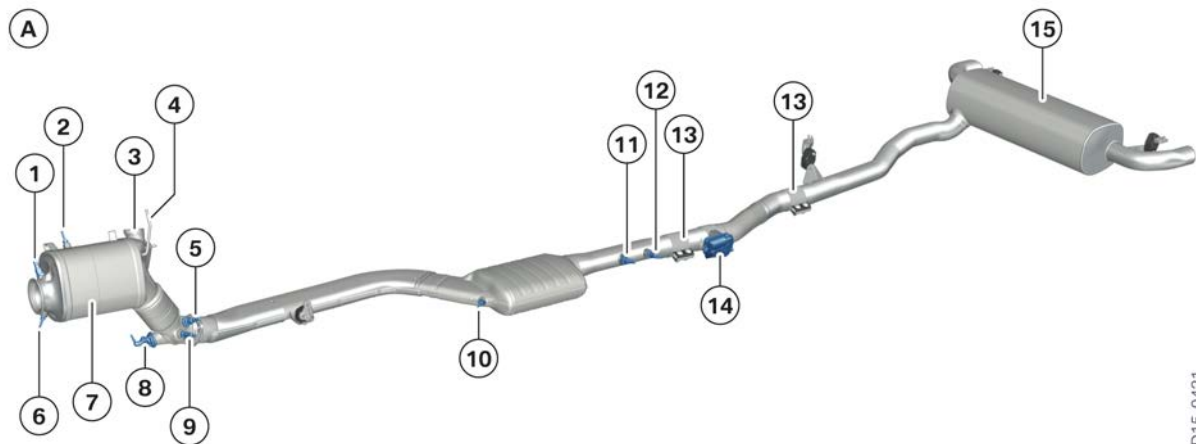

TD15-0421

BMW G30 B57 engine exhaust systems

Index	Explanation
A	Exhaust system B57D3000
1	Broadband oxygen sensor upstream of diesel particulate filter (LSU 5.1)
2	Exhaust-gas temperature sensor upstream of diesel particulate filter
3	Connecting flange for low-pressure exhaust-gas recirculation
4	Pressure connections for differential pressure sensor
5	Broadband oxygen sensor downstream of diesel particulate filter (LSU 5.1)
6	Exhaust temperature sensor upstream of catalytic converter
7	Upstream catalytic converter
8	SCR metering module
9	NO <sub>x</sub> sensor before the SCR catalytic converter
10	Exhaust temperature sensor upstream of SCR catalytic converter
11	Diesel particulate sensor (only US version)
12	NO <sub>x</sub> sensor after SCR catalytic converter
13	Service disconnection points
14	Exhaust gas restriction flap
15	Rear silencer

The B57 engine is delivered with the EURO 6 equipment specification as standard.



# B57 Engine

## 6. Intake Air and Exhaust System

Depending on the exhaust emission standards, different exhaust re-treatment systems are used as shown in the following overview.

Engine variant	Exhaust re-treatment system
B57D3000 EURO 6	<ul style="list-style-type: none"><li>• High-pressure exhaust-gas recirculation</li><li>• Low-pressure exhaust-gas recirculation</li><li>• Upstream catalytic converter<ul style="list-style-type: none"><li>- NSC (NO<sub>x</sub> storage catalyst)</li><li>- Diesel particulate filter</li><li>- Diesel particulate matter sensor (US)</li></ul></li><li>• SCR System</li></ul>

### 6.5. Exhaust-gas recirculation

To comply with current and future nitrogen oxide limit values, in addition to exhaust re-treatment measures such as Selective Catalytic Reduction (SCR) or nitrogen oxide catalytic converters, a clear reduction in raw emissions is also required. For diesel engines, one of the most important measures to reduce nitrogen oxide emissions is exhaust-gas recirculation.

Nitrogen oxide is created in larger quantities when combustion occurs with excess air and at a very high temperature. Here the oxygen bonds with the nitrogen from the combustion air to form nitrogen monoxide (NO) and nitrogen dioxide (NO<sub>2</sub>).

The following advantages result from exhaust-gas recirculation:

- Lower oxygen and nitrogen content in the cylinder
- Lowering of the peak combustion temperature by up to 500° C (932° F)
  - This effect is increased by the cooling of the recirculated exhaust gases.

So far, the high-pressure exhaust-gas recirculation was mainly needed in the partial load range as it is here where a particularly high level of excess air is dealt with.

With the G30, the BMW Group has committed itself to pre-compliance with the Real Drive Emission (RDE) driving cycle. The RDE driving cycle mainly differs due to higher full load ratios.

To apply the exhaust-gas recirculation up to full load, the following measures are required:

- Extension of the exhaust-gas recirculation up to full load range.
- Increase in level of exhaust-gas recirculation.
- Reduction in the returned exhaust temperature.

# B57 Engine

## 6. Intake Air and Exhaust System

With the high-pressure exhaust-gas recirculation alone, it is not possible to implement the measures mentioned above. This would be at the expense of the performance, efficiency of the engine. This means that the use of low-pressure exhaust-gas recirculation is necessary.

The following graphic contains a schematic illustration of the design of the two exhaust-gas recirculation systems without corresponding sensors.

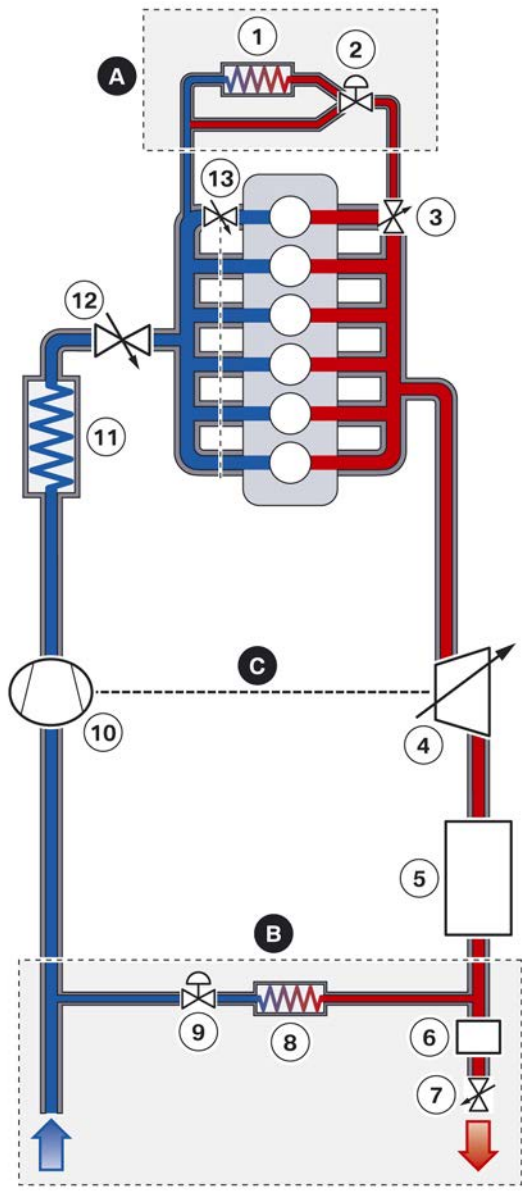

Schematic diagram of high and low-pressure exhaust-gas recirculation for B57 engine in the G30

# B57 Engine

## 6. Intake Air and Exhaust System

Index	Explanation
A	High-pressure exhaust-gas recirculation
B	Low-pressure exhaust-gas recirculation
C	Exhaust turbocharger
1	Exhaust-gas recirculation cooler, high-pressure EGR
2	Bypass valve, exhaust-gas recirculation cooler, high-pressure EGR
3	Exhaust-gas recirculation valve, high-pressure EGR
4	Controller, variable turbine geometry
5	NO <sub>x</sub> storage converter and diesel particulate filter
6	Selective Catalytic Reduction catalytic converter (SCR catalytic converter)
7	Exhaust gas restriction flap
8	Exhaust-gas recirculation cooler, low-pressure EGR
9	Exhaust-gas recirculation valve, low-pressure EGR
10	Compressor exhaust turbocharger
11	Charge air cooler
12	Throttle valve
13	Swirl-flap actuator

With low-pressure exhaust-gas recirculation, the exhaust gas is extracted after the diesel particulate filter and fed into the fresh air pipe via an exhaust-gas recirculation cooler. The cooled exhaust gases are fed into the clean air downstream of the hot film air mass meter and upstream of the turbocharger. Damage is avoided by taking the exhaust gases downstream of the diesel particulate filter as well as by the use of a specially coated compressor impellers in the turbochargers.

The pressure gradient between intake and exhaust emission systems must be partially adapted in order to achieve corresponding exhaust-gas recirculation rates for the particular operating point. The electrically actuated exhaust-gas recirculation valve releases a cross-section adapted to the operating point. Using an electrically actuated exhaust gas restriction flap located downstream of the Selective Catalytic Reduction (SCR) catalytic converter, is used to create back pressure so that the exhaust gas pressure is increased in the exhaust system. The correct volume of exhaust gas is supplied to the fresh air pipe at all operating points by simultaneous control of the two actuators.

**Due to stricter US market exhaust emissions legislation, when the M57TU2 US engine was introduced in 11/2008; low-pressure exhaust-gas recirculation was combined with high-pressure exhaust-gas recirculation to meet the exhaust emissions requirements.**

The following table provides a quick overview of the differences between the two exhaust-gas recirculation systems used:

# B57 Engine

## 6. Intake Air and Exhaust System

	<b>Low-pressure exhaust-gas recirculation</b>	<b>High-pressure exhaust-gas recirculation</b>
Operating readiness	Coolant temperature > 60°C Ambient temperature > 9°C	Directly after engine start, irrespective of coolant and ambient temperature.
Exhaust gas extraction	Downstream of diesel particulate filter.	From the exhaust manifold upstream of the exhaust turbocharger.
Cooling of the exhaust gases	Low-pressure exhaust-gas recirculation cooler and charge air cooler.	High-pressure exhaust-gas recirculation cooler.
Exhaust gas feed	Into the clean air pipe upstream of the exhaust turbocharger.	Into the intake system downstream of the throttle valve.
Efficiency of the exhaust turbocharger	Exhaust flow at the turbine is independent from the EGR rate.	Exhaust flow at the turbine decreases with an increasing EGR rate.
Exhaust-gas recirculation section	<ul style="list-style-type: none"> <li>• Low-pressure exhaust-gas recirculation module</li> <li>• Clean air pipe</li> <li>• Exhaust turbocharger</li> <li>• Charge air cooler</li> <li>• Intake manifold</li> </ul>	<ul style="list-style-type: none"> <li>• High-pressure exhaust-gas recirculation module</li> <li>• Intake manifold</li> </ul>

The following figure shows the high and low-pressure exhaust-gas recirculation system on the B57D30T0. In terms of function, there are no differences to the B57D30O0.

# B57 Engine

## 6. Intake Air and Exhaust System

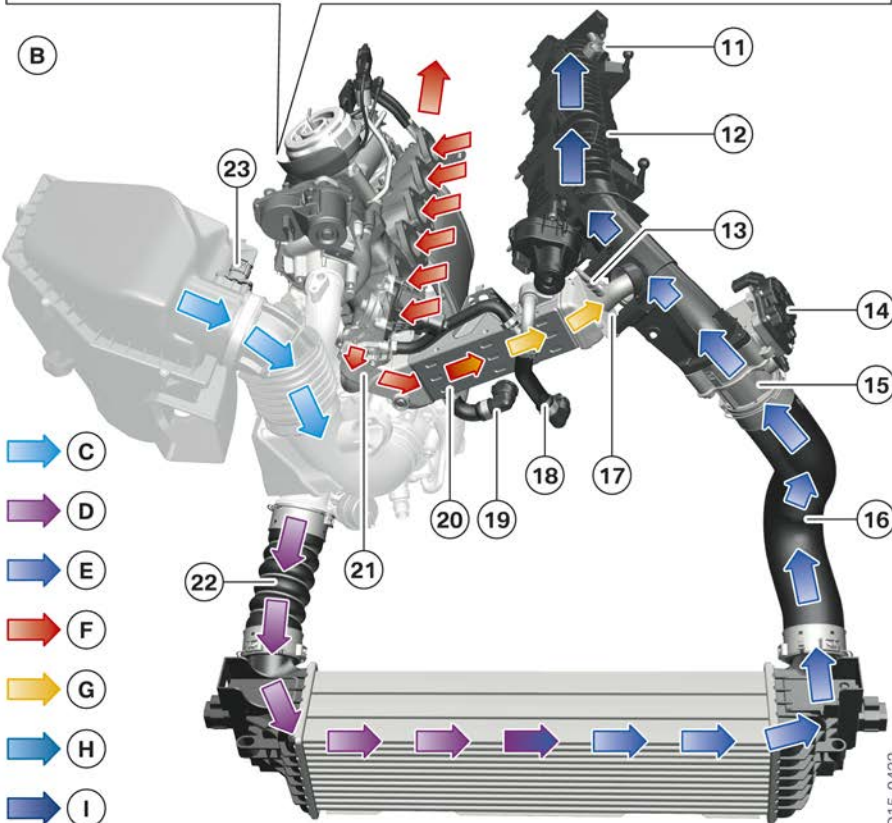
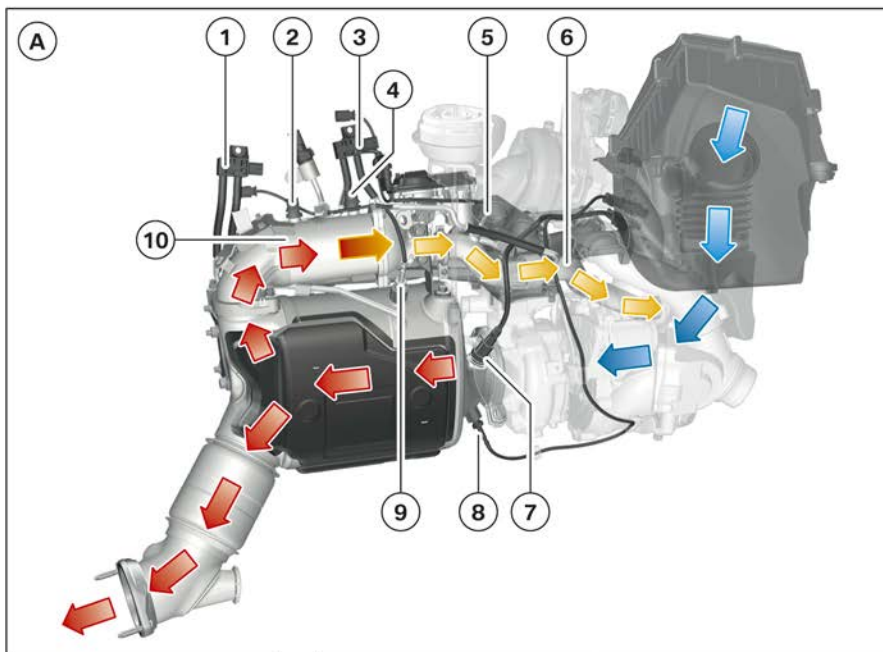

Overview of high and low pressure EGR for the B57 engine

TD15-0422

# B57 Engine

## 6. Intake Air and Exhaust System

Index	Explanation
A	Low-pressure exhaust-gas recirculation
B	High-pressure exhaust-gas recirculation
C	Purified air
D	Heated charge air with exhaust gases from the low-pressure exhaust-gas recirculation
E	Cooled charge air with exhaust gases from the low-pressure exhaust-gas recirculation
F	Exhaust gases
G	Cooled exhaust gases
H	Mixture of clean air and cooled exhaust gases from the low-pressure exhaust-gas recirculation
I	Mixture of purified charge air and cooled exhaust gases from the high and low-pressure exhaust-gas recirculation
1	Differential pressure sensor on the diesel particulate filter
2	Coolant supply
3	Differential pressure sensor on the low-pressure exhaust-gas recirculation module
4	Coolant return
5	Exhaust temperature sensor downstream of low-pressure exhaust-gas recirculation
6	Low-pressure exhaust-gas recirculation pipe
7	Broadband oxygen sensor upstream of diesel particulate filter (LSU 5.1)
8	Exhaust temperature sensor upstream of catalytic converter
9	Exhaust-gas temperature sensor upstream of diesel particulate filter
10	Low-pressure exhaust-gas recirculation module
11	Charging pressure sensor
12	Intake manifold
13	Exhaust temperature sensor downstream of high-pressure exhaust-gas recirculation
14	Electromotive throttle controller with path feedback
15	Adaptor pipe with charge-air temperature sensor
16	Charge air hose
17	High-pressure exhaust-gas recirculation mixing tube
18	Coolant return, high-pressure exhaust gas recirculation
19	Coolant supply, high-pressure exhaust-gas recirculation

# B57 Engine

## 6. Intake Air and Exhaust System

Index	Explanation
20	High-pressure exhaust-gas recirculation cooler
21	High-pressure exhaust gas-recirculation valve with path feedback
22	Charge air hose
23	Hot film air mass meter (HFM 8)

### 6.5.1. High-pressure exhaust-gas recirculation

The high-pressure exhaust-gas recirculation reduces the exhaust flow at the turbine wheel of the exhaust turbocharger. In order to balance the required charging pressure in operating phases with high-pressure exhaust-gas recirculation, the exhaust gas pressure and therefore the energy supplied to the turbine wheel are increased by closing the guide vanes as required.

If the EGR rate is increased further, the exhaust turbocharger may no longer be able to supply the engine with the necessary mixture of fresh air and exhaust gas. The exhaust turbocharger would meet the pump limit.

Furthermore, recirculation of exhaust gases up to full load is quite difficult and, due to the charging pressure in the intake system, it is only possible by making relatively high use of the throttle valve.

This would lead to the following restrictions in the engine operation:

- Maximum charging pressure would not be reached
  - Lower peak engine torque
- Increase in fuel consumption
- Lower engine efficiency

The optimum combination of high-pressure and low-pressure exhaust-gas recirculation therefore constitutes an effective measure to lower nitrogen oxide levels and to increase the efficiency of the engine.

The high-pressure exhaust-gas recirculation module is composed of the following components:

- Exhaust-gas recirculation cooler
- Exhaust-gas recirculation valve

# B57 Engine

## 6. Intake Air and Exhaust System

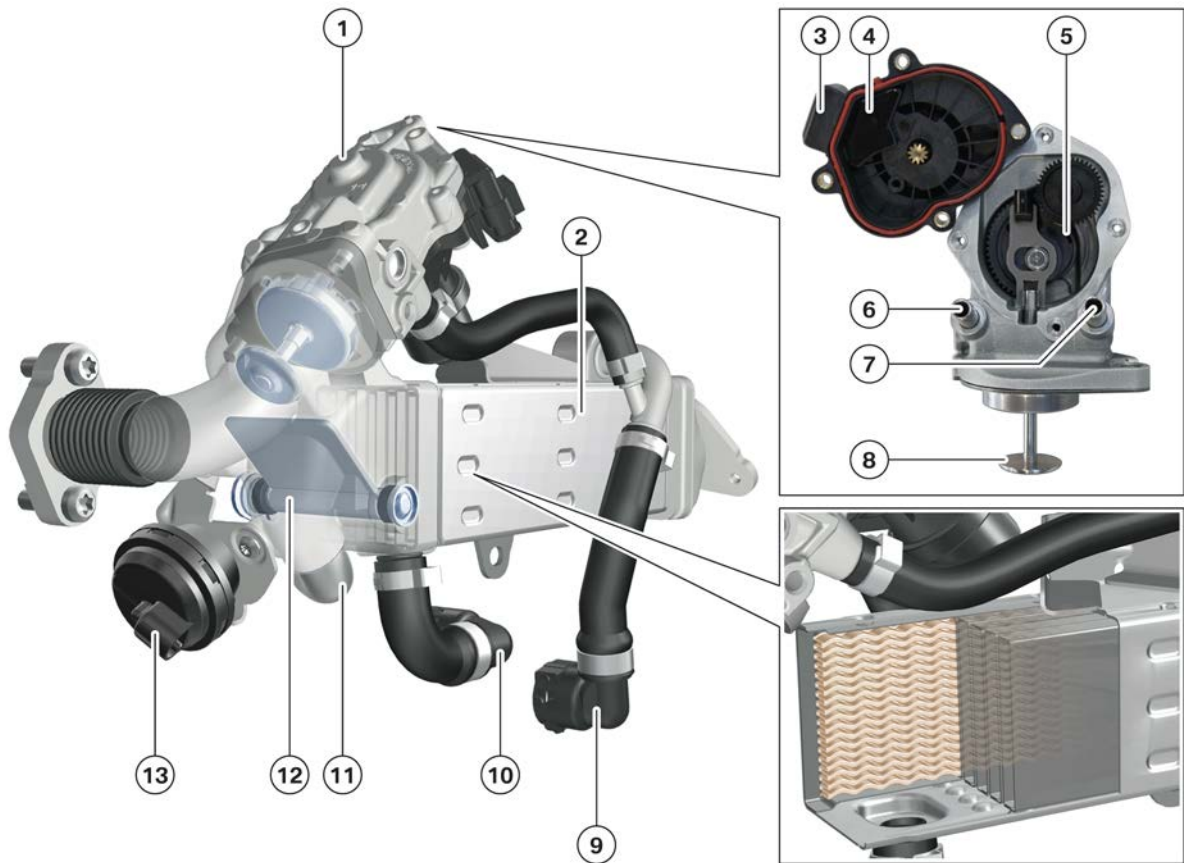

High-pressure exhaust-gas recirculation, B57 engine

Index	Explanation
1	High-pressure exhaust-gas recirculation valve with path feedback
2	High-pressure exhaust-gas recirculation cooler
3	Electrical connection
4	Sensor unit
5	Return spring
6	Coolant connection, exhaust-gas recirculation valve, output
7	Coolant connection, exhaust-gas recirculation valve, input
8	Valve head
9	Coolant connection, exhaust-gas recirculation cooler, output
10	Coolant connection, exhaust-gas recirculation cooler, input
11	Bypass channel
12	Bypass flap
13	Vacuum unit, bypass flap



# B57 Engine

## 6. Intake Air and Exhaust System

### EGR valve

The electronically operated exhaust-gas recirculation valve controls the recirculation of exhaust gases to the air intake system and is located upstream of the exhaust-gas recirculation cooler. Due to the hot installation location, the valve is subject to a high thermal load and must be cooled by the coolant to protect the electronic components.

A spring-loaded closing function means that the valve is normally closed by default. This prevents the recirculation of exhaust gases in the case of a fault.

### Exhaust-gas recirculation cooler

The exhaust-gas recirculation cooler increases the efficiency of the EGR. The cooled exhaust gas is able to absorb more thermal energy and to therefore reduce the peak combustion temperature.

The thermal energy from the exhaust gases is transferred to the coolant via plate heat exchangers. The exhaust gases are swirled through so-called "wavy fins". This wave formation of the fins increases heat dissipation and reduces the tendency for blockages as a result of condensate deposits.

Exhaust-gas recirculation makes it possible to introduce cooled or un-cooled exhaust gases into the intake manifold. It is useful to introduce un-cooled exhaust gases in the engine warm-up phase. The vacuum-controlled bypass flap enables switching between cooled and un-cooled exhaust-gas recirculation operation.

### 6.5.2. Low-pressure exhaust-gas recirculation

In addition to high-pressure exhaust-gas recirculation, the B57 engines also have low-pressure exhaust-gas recirculation. The low-pressure exhaust-gas recirculation takes the exhaust gases downstream of the diesel particulate filter and feeds them to the clean air upstream of the exhaust turbocharger compressor. Through this, the volumetric flow of exhaust gas at the turbine is not negatively influenced with an increasing EGR rate. Thanks to the suction power of the compressor, exhaust gases can be recirculated even at high engine speed and load.

In contrast to the high-pressure exhaust-gas recirculation system, the recirculated exhaust gas is cooled together with the fresh air downstream of the compressor in the charge air cooler in order to maximise the combustion efficiency.

The use of low-pressure exhaust-gas recirculation offers the following advantages:

- Higher exhaust mass flow at the turbine.
- Higher volumetric flow at the compressor.
- Increase of the charging pressure and the cylinder charge.

The low-pressure exhaust-gas recirculation not only increases the efficiency of the turbocharger, but also improves the overall efficiency of the engine.

This results in the following advantages for engine operation:

- Consumption optimization
- Reduction in CO<sub>2</sub> emissions
- Improved dynamics and response characteristics of the exhaust turbocharger

# B57 Engine

## 6. Intake Air and Exhaust System

The low-pressure exhaust-gas recirculation is only active from a coolant temperature  $> 60^{\circ}\text{C}$  ( $140^{\circ}\text{F}$ ) and an ambient temperature  $> 9^{\circ}\text{C}$  ( $48^{\circ}\text{F}$ ). During cold start and warm-up, the water vapor in the exhaust gas may condense if the temperature drops below dew point. The impeller may become damaged by the water droplets. This is known as droplet impact and must be avoided under all circumstances. The installation position of the low-pressure exhaust-gas recirculation module is therefore inclined by  $7^{\circ}$  toward the rear in order to allow condensate to drain away to the exhaust system.

The low-pressure exhaust-gas recirculation is comprised of the following components:

- Exhaust filter
- Low-pressure exhaust-gas recirculation module
  - Low-pressure exhaust-gas recirculation cooler
  - Low-pressure exhaust-gas recirculation valve

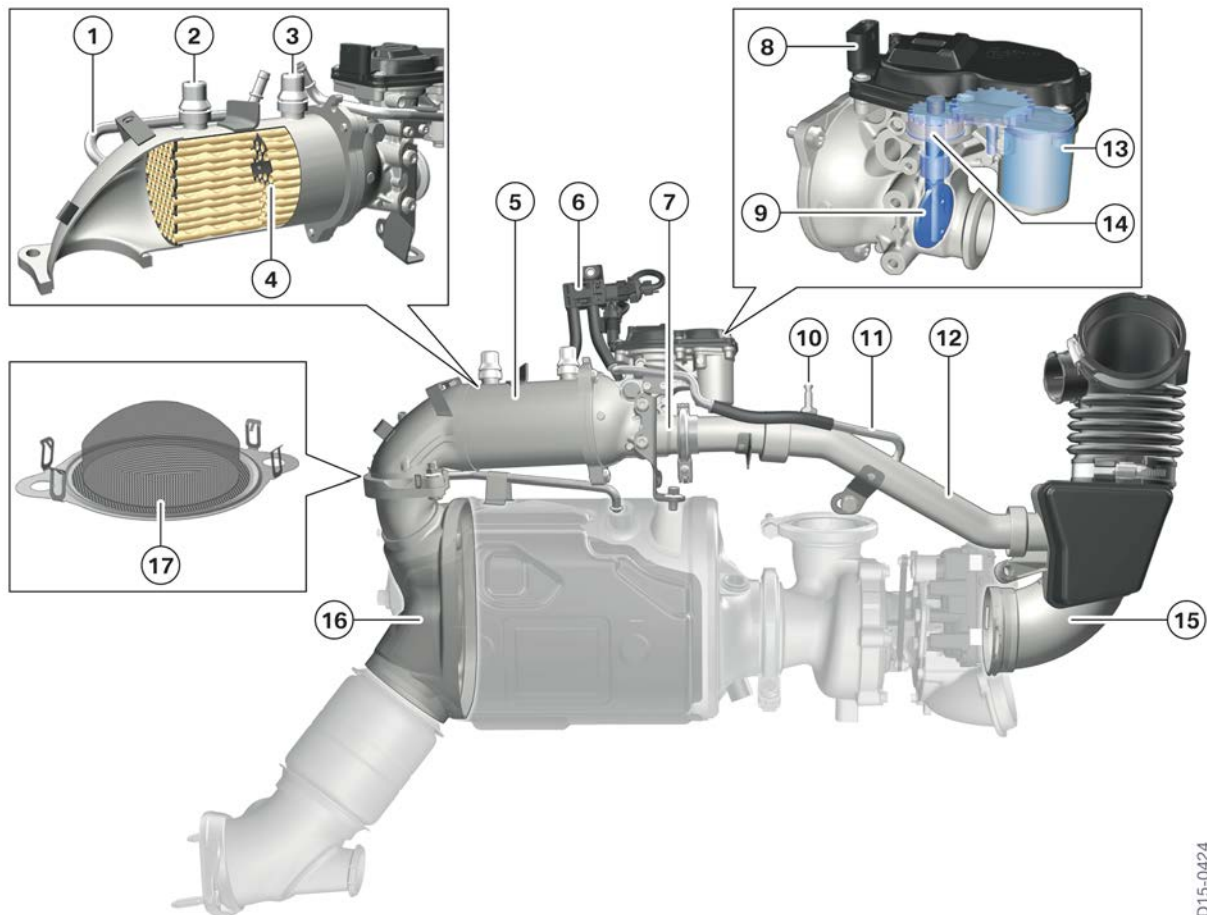

Low-pressure exhaust-gas recirculation, B57 engine

TD15-0424

# B57 Engine

## 6. Intake Air and Exhaust System

Index	Explanation
1	Differential pressure pipe upstream of low-pressure exhaust-gas recirculation module
2	Coolant supply
3	Coolant return
4	Heat exchanger
5	Low-pressure exhaust-gas recirculation cooler
6	Differential pressure sensor on the low-pressure exhaust-gas recirculation module
7	Low-pressure exhaust-gas recirculation valve
8	Electrical connection
9	Valve flap
10	Exhaust temperature sensor downstream of low-pressure exhaust-gas recirculation module
11	Differential pressure pipe downstream of low-pressure exhaust-gas recirculation module
12	Low-pressure exhaust-gas recirculation pipe
13	Low-pressure exhaust-gas recirculation valve drive
14	Return spring
15	Clean air pipe
16	Diesel particulate filter
17	Exhaust filter

### Exhaust filter

In the gasket between the diesel particulate filter and low-pressure exhaust-gas recirculation system there is a fine metal filter. This is used to prevent any particles that are generated in the diesel particulate filter manufacturing process from getting into the low-pressure exhaust-gas recirculation system. These particles would hit the compressor blades of the turbocharger and cause them damage.

### Exhaust-gas recirculation cooler

The cooling of the low-pressure exhaust-gas recirculation mass flow is also necessary in order to keep the temperature of the mix of fresh air and recirculated exhaust gas as low as possible. The cooling reduces the compressor temperature and increases its efficiency.

The low-pressure exhaust-gas recirculation cooler has a tubular design. The exhaust gases flow through the coolant pipes and transfer the heat to the surrounding coolant.

# B57 Engine

## 6. Intake Air and Exhaust System

### EGR valve

The electronically operated low-pressure exhaust-gas recirculation valve is similar in design to the throttle valve and adjusts the low-pressure exhaust-gas recirculation mass flow together with the exhaust gas restriction flap. Due to a fail-safe feature, the exhaust-gas recirculation valve closes in order to prevent the recirculation of further exhaust gases.

The low-pressure exhaust-gas recirculation valve is installed on the cold side (cold installation position) downstream of the exhaust-gas recirculation cooler and therefore requires no further cooling.

The exhaust-gas recirculation valve of the low-pressure exhaust-gas recirculation is also activated by the Digital Diesel Electronics.

### 6.5.3. Exhaust gas restriction flap

The exhaust gas restriction flap is located behind the nitrogen oxide catalytic converter and can be specifically activated by the Digital Diesel Electronics at low-load operating points. At this engine operating range, the exhaust gas pressure is too low to be able to recirculate exhaust gases. The exhaust gas restriction flap narrows the cross-section of the exhaust pipe in a controlled manner, increasing the exhaust gas back-pressure in the exhaust emission system. Due to the simultaneous control of the exhaust gas restriction flap and the low-pressure exhaust-gas recirculation controller, the required volume of exhaust gas is recirculated in every operating range.

The exhaust gas restriction flap also has a fail-safe feature, which causes the restriction flap to open. This measure is required to prevent excessive back- pressure of exhaust gases in the event of a fault.

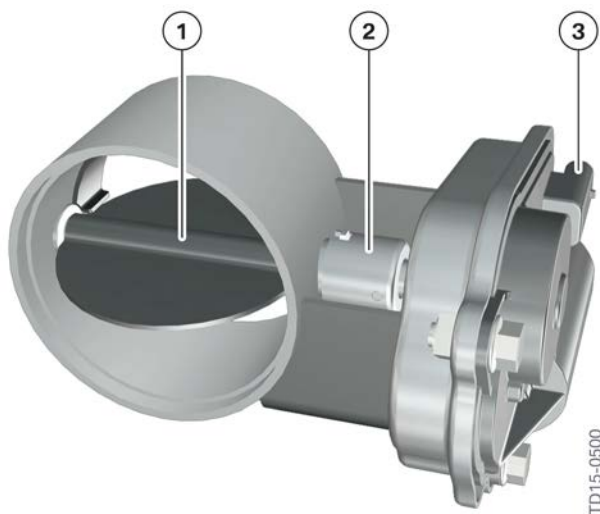

Exhaust gas restriction flap, B57 engine

Index	Explanation
1	Restriction flap
2	Linking element
3	Electrical connection

# B57 Engine

## 6. Intake Air and Exhaust System

### Electrical controller, exhaust gas restriction flap

The exhaust gas restriction flap is an intelligent controller drive, or "smart controller". The set-point values are stipulated by the Digital Diesel Electronics and transmitted via a pulse-width modulated signal to the exhaust gas restriction flap. The set-point position is approached on the basis of the incoming pulse-width modulated signal via an integrated control logic inside the exhaust gas restriction flap. The pulse-width modulated signal therefore serves solely to transfer data and not to supply the DC motor.

The duty cycle of the pulse-width modulated signal is "low active". This means that for a 10% duty cycle, the signal line is "low" for 10% of the time, and for 90% of the time is "high".

The exhaust gas restriction flap has the following connections:

- Voltage supply
- Ground connection
- Pulse width modulation signal line with fault reporting.

Exhaust gas restriction flap	Duty cycle at the exhaust gas restriction flap Pulse width modulation input
Teach-in end stops	5%
Position open	10%
Intermediate settings	> 10% - < 90%
Position closed	90%

The exhaust gas restriction flap not only receives the trigger signal via the pulse width modulation signal line, but it can also transmit faults to the Digital Diesel Electronics. This is possible as the control unit of the exhaust gas restriction flap grounds the pulse width modulation signal line. In the event of a fault, this is not permanent but in pulses. The Digital Diesel Electronics can specifically recognise faults through the frequency and duration of this pulsing.

The control unit of the exhaust gas restriction flap can transmit the following faults to the Digital Diesel Electronics:

Fault pattern	Explanation
Blockage of the controller drive	Adjustment process longer than a pre-defined time
Excess temperature	For temperatures > 145° C (293° F)
Under/overvoltage	For supply voltages < 8.5 V and > 17 V

# B57 Engine

## 6. Intake Air and Exhaust System

### 6.5.4. Exhaust-gas recirculation control

The control of the EGR is model-based, the same as charging pressure control (MCC = Model-Based Charge Control). An EGR characteristic map integrated in the Digital Diesel Electronics provides the air mass set-point values which correspond to the current engine operation. These are then transferred to the engine operation taking into consideration the physical control limits.

In terms of control, this means that the exhaust-gas recirculation control of the B57 engine has to activate the following 4 actuators:

- High-pressure exhaust-gas recirculation valve
- Throttle valve
- Low-pressure exhaust-gas recirculation valve
- Exhaust gas restriction flap

The control section of the low-pressure exhaust-gas recirculation is considerably longer than that of the high-pressure exhaust-gas recirculation. This results in a time delay between the set-point and actual value during control. This is adjusted by simultaneous control of the high-pressure exhaust-gas recirculation and low-pressure exhaust-gas recirculation.

The model-based control has been expanded by the two new low-pressure exhaust-gas recirculation actuators. For the Digital Diesel Electronics, this means an additional set-point value which determines the distribution of the entire EGR mass flow in the high and/or low-pressure section.

Using the set-point values from B57D3000, the following diagram demonstrates the distribution of the entire EGR mass flow on the low-pressure exhaust-gas recirculation section.

With increasing engine speed and load, the recirculated proportion of the low-pressure exhaust-gas recirculation increases more and more. From a particular engine operation range, the high-pressure exhaust-gas recirculation is closed and the exhaust gases are only recirculated through the low-pressure exhaust-gas recirculation. This increases the efficiency of the exhaust turbocharger and therefore of the entire engine.

# B57 Engine

## 6. Intake Air and Exhaust System

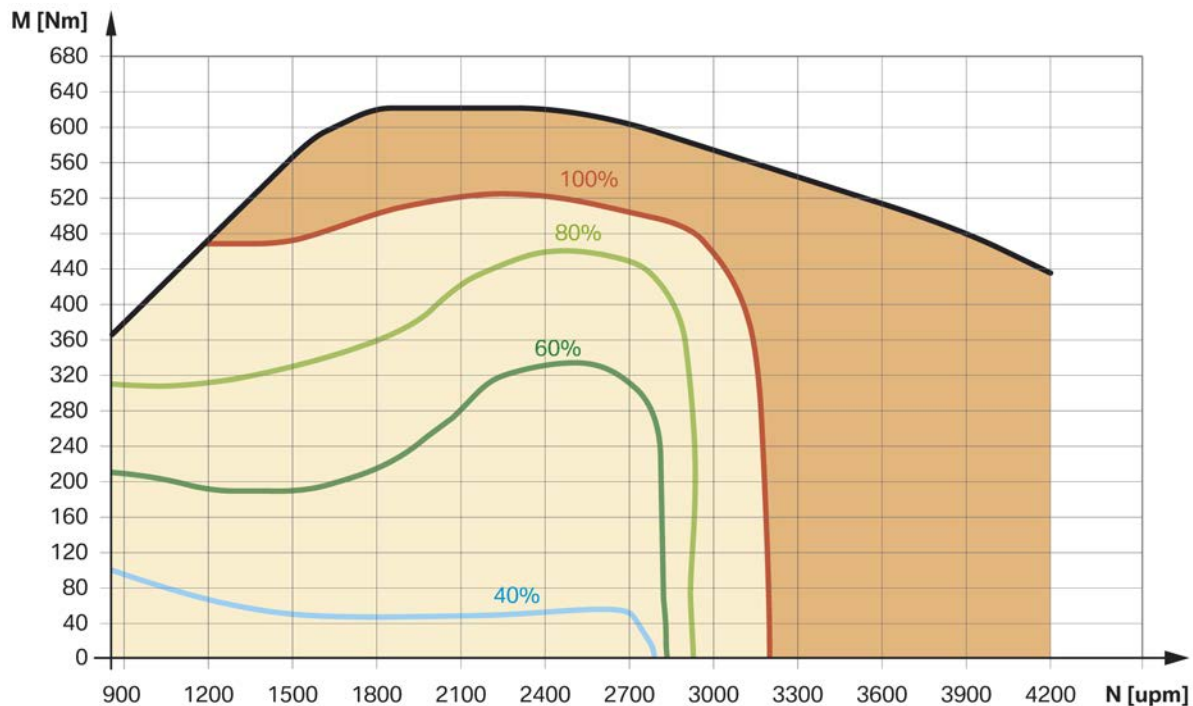

Ⓐ    Ⓑ

TD15-0544

Proportion of low-pressure exhaust-gas recirculation, B57D3000

Index	Explanation
A	Range with high and low-pressure exhaust-gas recirculation
B	Range only with low-pressure exhaust-gas recirculation

In the process, the set-point values for air mass designed for optimal emission behavior are adjusted in such a way that the physical limits are not exceeded. In a downstream calculation model, the control values needed for the actuators are determined by taking into account all operational and ambient conditions.

Using the following sensors, the recirculated exhaust gas masses can be determined exactly:

- Exhaust back-pressure sensor upstream of exhaust turbocharger
- Differential pressure sensor on the low-pressure exhaust-gas recirculation module
- Exhaust temperature sensor downstream of high-pressure exhaust-gas recirculation cooler

These set-point values are especially important in rich operation, as here the volumes of fresh air and the recirculated exhaust gas must be coordinated with each other exactly.

The exhaust temperature sensor downstream of the low-pressure exhaust-gas recirculation cooler not only serves to determine the EGR rate, but the measured values are also purely used for diagnostic purposes.

# B57 Engine

## 7. Vacuum Supply

The vacuum system provides the opportunity to activate components. For this, a vacuum pump generates the vacuum which is distributed via the lines.

### 7.1. System overview

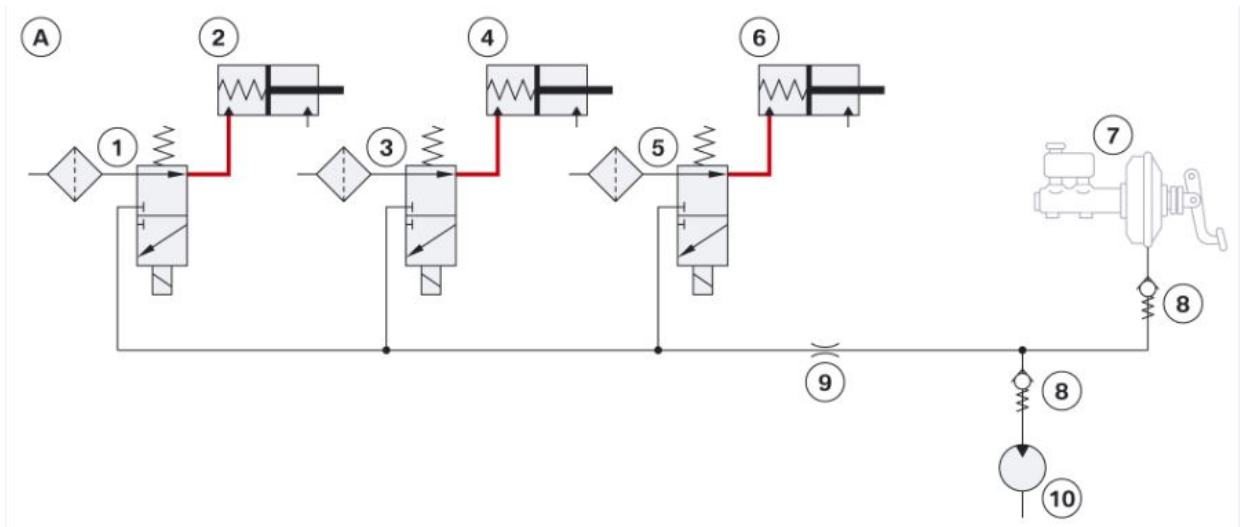

Schematic diagram of vacuum supply, B57 engine

Index	Explanation
A	Vacuum supply for the B57D3000 engine
1	Electric changeover valve for bypass flap on the exhaust-gas recirculation cooler
2	Vacuum unit for bypass flap on the exhaust-gas recirculation cooler
3	Electric changeover valve for the vacuum controlled coolant pump
4	Vacuum unit for the vacuum controlled coolant pump
5	Electric changeover valve for vacuum controlled engine mount
6	Vacuum unit for vacuum controlled engine mount
7	Brake servo
8	Non-return valve
9	Throttle
10	Vacuum pump



# B57 Engine

## 7. Vacuum Supply

### 7.1.1. Electric changeover valve

The electric changeover valve either connects through the vacuum to the vacuum unit or shuts it off. It is not an infinitely variable control, but a "ON/OFF" control.

The following components are activated by an electric changeover valve:

- Bypass flap of the exhaust-gas recirculation cooler
- Vacuum controlled coolant pump
- Vacuum controlled engine mount

# B57 Engine

## 8. Fuel System

The fuel system is made up of the fuel supply and fuel preparation systems. The fuel supply system includes the fuel tank with all the mounted parts, the fuel lines leading to the engine compartment and the fuel filter with the fuel filter heating.

The fuel lines in the engine compartment and all the fuel system parts on the engine belong to the fuel preparation system.

### 8.1. Fuel supply

The fuel supply is described in the respective information bulletins for the vehicle models.



It is essential to ensure that only approved diesel fuel (standard automotive fuel) is used in the vehicle. The complete fuel system is designed for approved fuels and may be damaged if non-approved fuels are used.

### 8.2. Fuel preparation

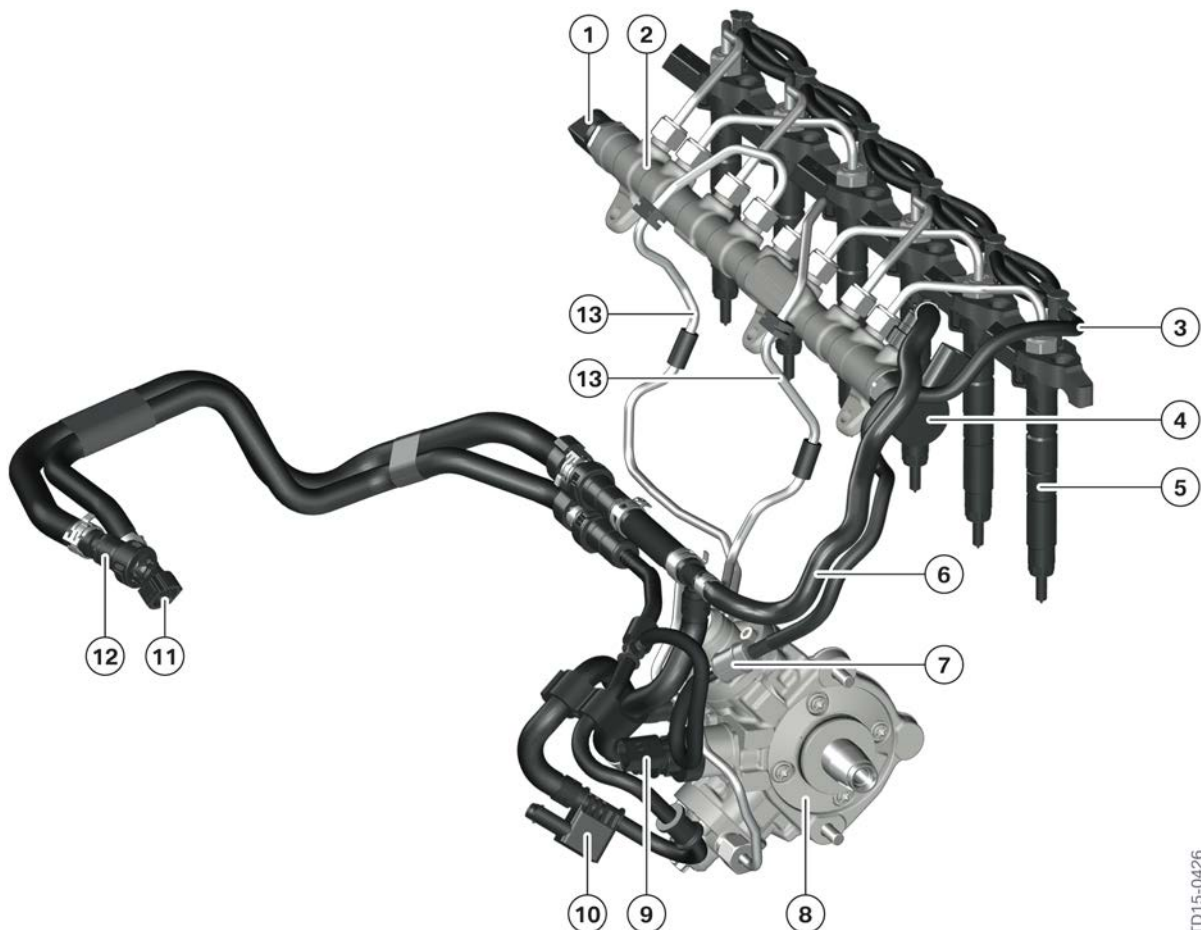

Fuel preparation, B57 engine

TD15-0426

# B57 Engine

## 8. Fuel System

Index	Explanation
1	Rail pressure sensor
2	Rail (HFR25)
3	Leakage oil line
4	Pressure control valve
5	Injector (CRI 3.25)
6	Return line
7	Reverse throttle
8	High pressure pump (CP 4.2–25)
9	Fuel quantity control valve
10	Fuel pressure and fuel temperature sensor
11	Fuel feed (blue connection)
12	Fuel return (black connection)
13	High pressure lines

The fuel preparation system of the B57D3000 engine was adapted to the requirements of the emissions legislations. The engine uses the 3rd generation common rail system CRS 3 equipped with piezo injectors.

In comparison to the solenoid valve injectors, the piezo element generates a force which is around ten times stronger and is therefore less sensitive to small impurities in the fuel. Even for the precise metering of the smallest pre and post-injection amounts, as well as a steady amount over the operating time, the piezo injector is perfect for the highest demands.

Due to its modular design, the injection system can be adapted to the requirements of the 4 and 6-cylinder engines.

### 8.2.1. Overview of common rail systems

	N57D3001	B57D3000
High pressure pump	CP 4.2	CP 4.2
Injectors	CRI 2.18	CRI 3.25
Injectors Technology	Solenoid valve	Piezo
Highest passenger Fuel injection pressure	1800 bar	2500 bar
Minimum spraying distance	350 µs	150 µs
Maximum Quantity injections	7	8

# B57 Engine

## 8. Fuel System

### 8.2.2. High pressure pump CP 4.2/25

The high pressure pump has been modified in terms of stroke and cam profile in order to increase the delivery rate. The transmission ratio from the crankshaft to the high pressure pump has been selected in such a way that fuel delivery takes place synchronously to combustion. At the start of injection, the fuel is always simultaneously delivered to the rail, resulting in lower pressure fluctuations in the rail and therefore in the fuel injection pressure.

As part of the reworking of the housing and the cylinder heads, the weight of the pump was reduced. Furthermore, the control geometry of the fuel quantity control valve has been adjusted to the required quantity.

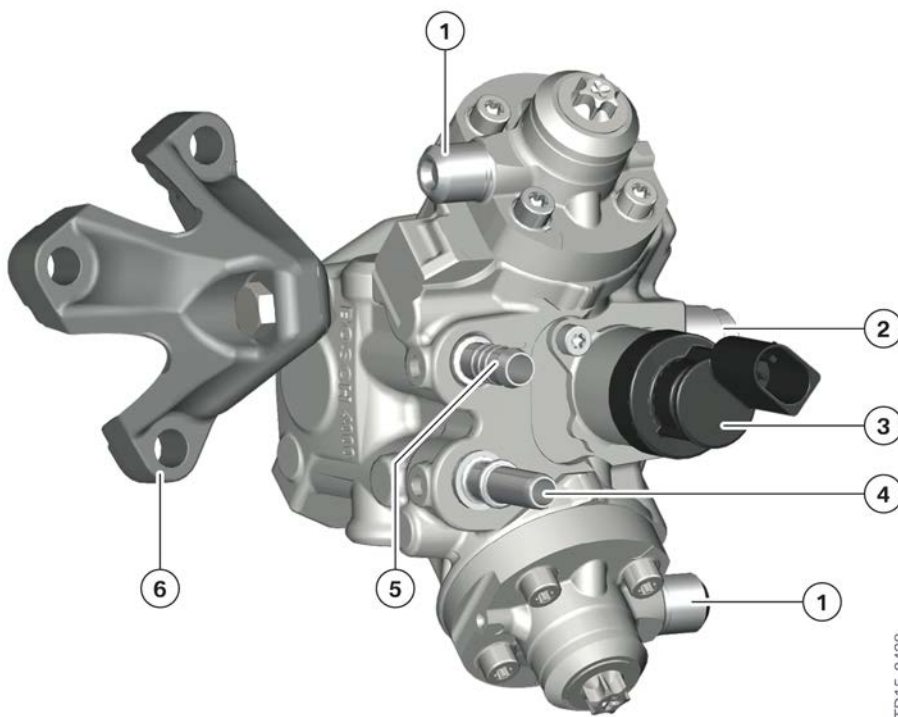

TD15-0429

High pressure pump, B57 engine

Index	Explanation
1	Connection for high pressure line to rail
2	Electric motor, high-pressure pump
3	Fuel quantity control valve
4	Fuel return line from the high pressure pump
5	Fuel feed to the high pressure pump
6	High pressure pump support

**Note:** A hose connection with hose clamp at the fuel feed and a snap fastener at the fuel return is used for the low pressure connections.

# B57 Engine

## 8. Fuel System



---

**If work is carried out on the chain drive, the high pressure pump must be positioned in relation to the crankshaft. Refer to the current repair instructions for the exact procedure.**

---

### 8.2.3. CRI 3.25 injectors

The B57D3000 engine has 3rd generation injectors which are activated using a piezo element. The maximum fuel injection pressure is 2500 bar.

The nozzle geometry of the injectors has been adapted with regards to the fuel quantity delivery in comparison to the injectors used in the lower power B57 engines.

Advantages of piezo technology:

- Higher efficiency due to injectors without permanent leakage
- More precise and faster control of the fuel injection rate due to the piezo element
- Lower fuel temperature
- Smaller and lighter size of the injectors
- Lower energy requirements

# B57 Engine

## 8. Fuel System

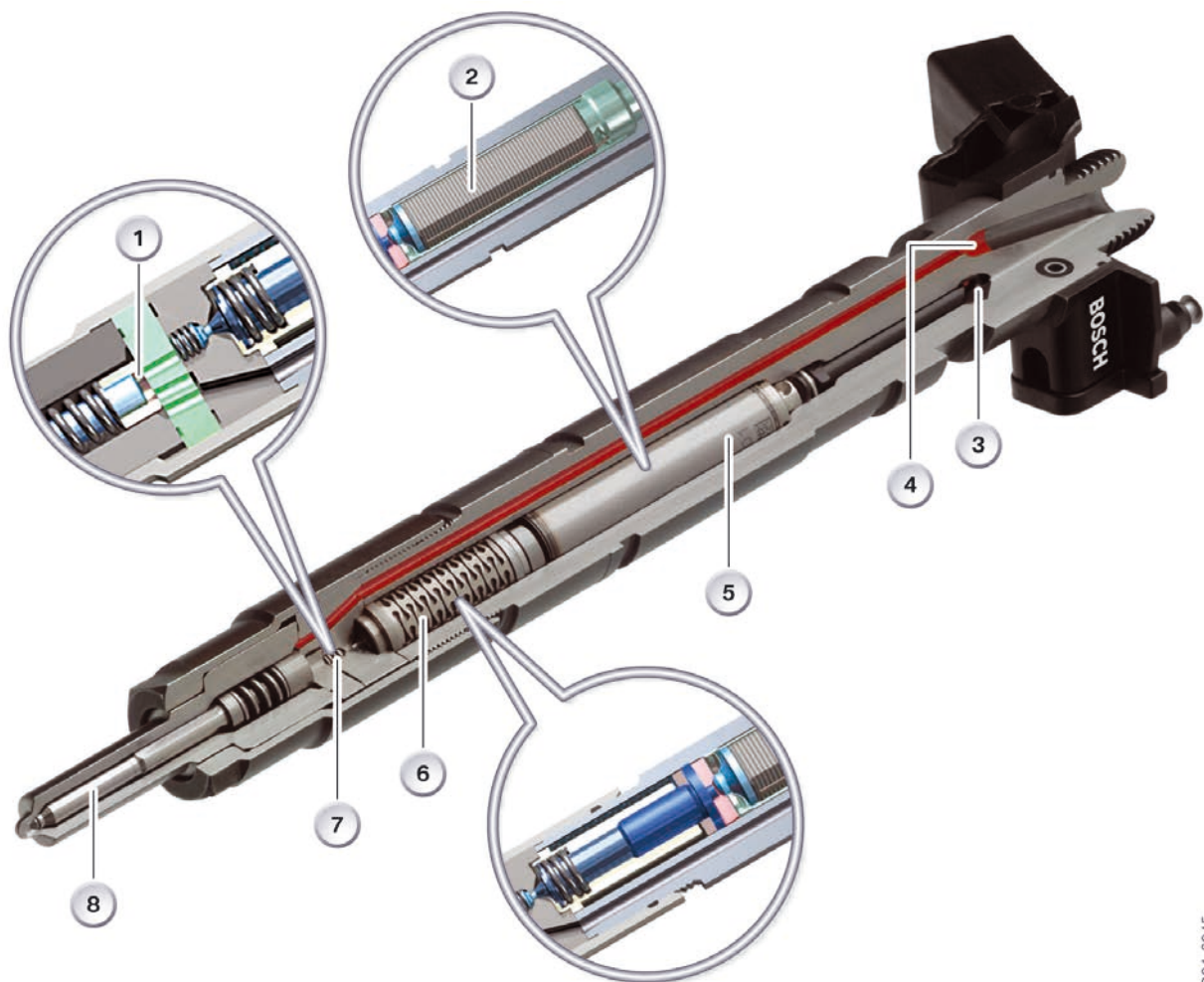

CRI 3.25 piezo injector

TD04-6045

Index	Explanation
1	Control space
2	Piezo element
3	Return channel
4	High-pressure supply to nozzle
5	Actuator module
6	Coupler module
7	Switching valve
8	Nozzle needle

The piezo element is located in the actuator module (5). The coupler module is connected between the actuator module and the shift valve. It functions as a hydraulic compensating element in order to compensate for longitudinal distortions caused by temperature. In order to translate the stroke movement of the piezo element to the control valve, a return pressure of 10 bar is required, which is set by the throttle in the fuel return of the injectors.

# B57 Engine

## 8. Fuel System

If the injector is activated, the actuator module lengthens. The movement is transferred via the coupler module to the shift valve. As the shift valve opens, the pressure in the control space decreases and the nozzle needle opens.

A charged piezo element would be constantly extended without discharge and there would be continuous injection. In order to prevent this, the piezo element is connected in parallel to a resistor, through which it can discharge itself in less than one second. This ensures that the injector is closed quickly to terminate the injection process.

The operating principles of injectors in common rail injection systems are similar, irrespective of the injector type (solenoid/piezo).

### Injection quantity compensation (IQC)

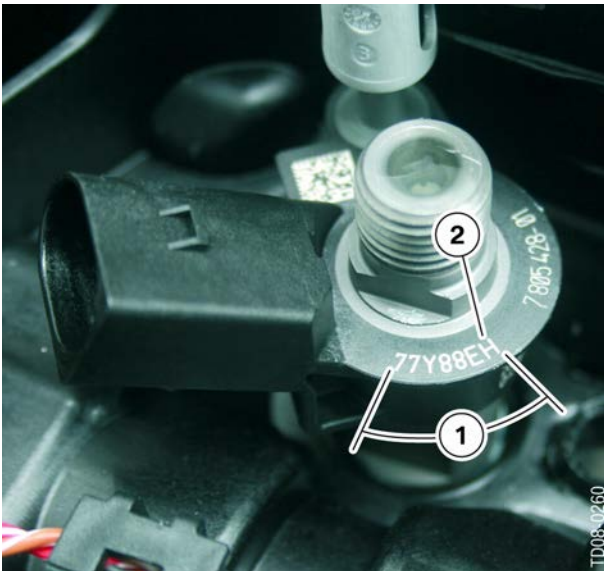

Injection quantity compensation, piezo injectors

Index	Explanation
1	Seven-position code (compensation value)
2	Injector voltage compensation

On account of the tolerance when the injectors are manufactured, the fuel quantity actually injected deviates slightly from the fuel quantity calculated. This deviation is determined after each injector is produced at various operating points by means of measurements. An adjustment value (IQC code) is created for each injector from these measurements. The Digital Diesel Electronics uses these adjustment values to make minor corrections to the calculated fuel injection rate and thereby reduces the cylinder-specific deviation.

As with the hydraulic tolerances, for the piezo injectors, additional information about the stroke behavior of the piezo element is added. This is a separate classification for the injector voltage compensation. This information is needed due to the individual voltage requirement of each injector.

# B57 Engine

## 8. Fuel System



---

**When injectors are replaced, it must be ensured that the alphanumeric code printed on each injector is assigned to the correct cylinder in the Digital Diesel Electronics (DDE).**

---

### 8.2.4. High pressure rail HFR 25

The B57 engine has the forged rail which is optimized for weight and adapted to the required pressure. The rail is no longer mounted using bearing shells but with 3 tabs on the cylinder head cover.

### 8.2.5. Leakage oil line

In terms of material, just as the other lines of the low-pressure fuel system, the leakage oil lines are adapted to the increased requirements. The connection with the injectors is the same as the engine.

As piezo injectors only function in a defined return pressure range, a pressure control valve has been integrated into the leakage oil line which maintains the fuel return pressure in a range between 9 and 11 bar. This fuel pressure is necessary for smooth operation of the piezo injector.

### 8.2.6. Rail pressure control

The high-pressure control is divided into the areas of pressure generation and pressure storage. The high pressure pump takes over the generation; the rail is responsible for storage. The function of the high-pressure control is to provide the optimum rail pressure in every operating condition of the engine.

The rail pressure control of the B57 engine also has the 2-controller concept. Following engine start and at low fuel temperatures, the rail pressure is controlled via the pressure control valve in the rail. The fuel quantity control valve takes over at normal operation.

The advantages of the 2-controller concept are:

- The performance of the high pressure pump could be reduced for engine operation temperature.
- Quicker heating of the fuel and breakup of any paraffin.

The rail pressure set-point value is corrected and adjusted due to the following ambient conditions:

- Atmospheric pressure
- Intake air temperature
- Engine temperature
- Fuel grade

If, for a pre-defined time period, the actual rail pressure deviates from the set-point value, switching occurs in a stepped manner from fuel quantity control to pressure regulation, and a corresponding fault code entry is set.



# **B57 Engine**

## **9. Engine Electrical System**

### **9.1. System wiring diagram**

The following overview illustrates the system wiring diagram of the B57 engine.

# B57 Engine

## 9. Engine Electrical System

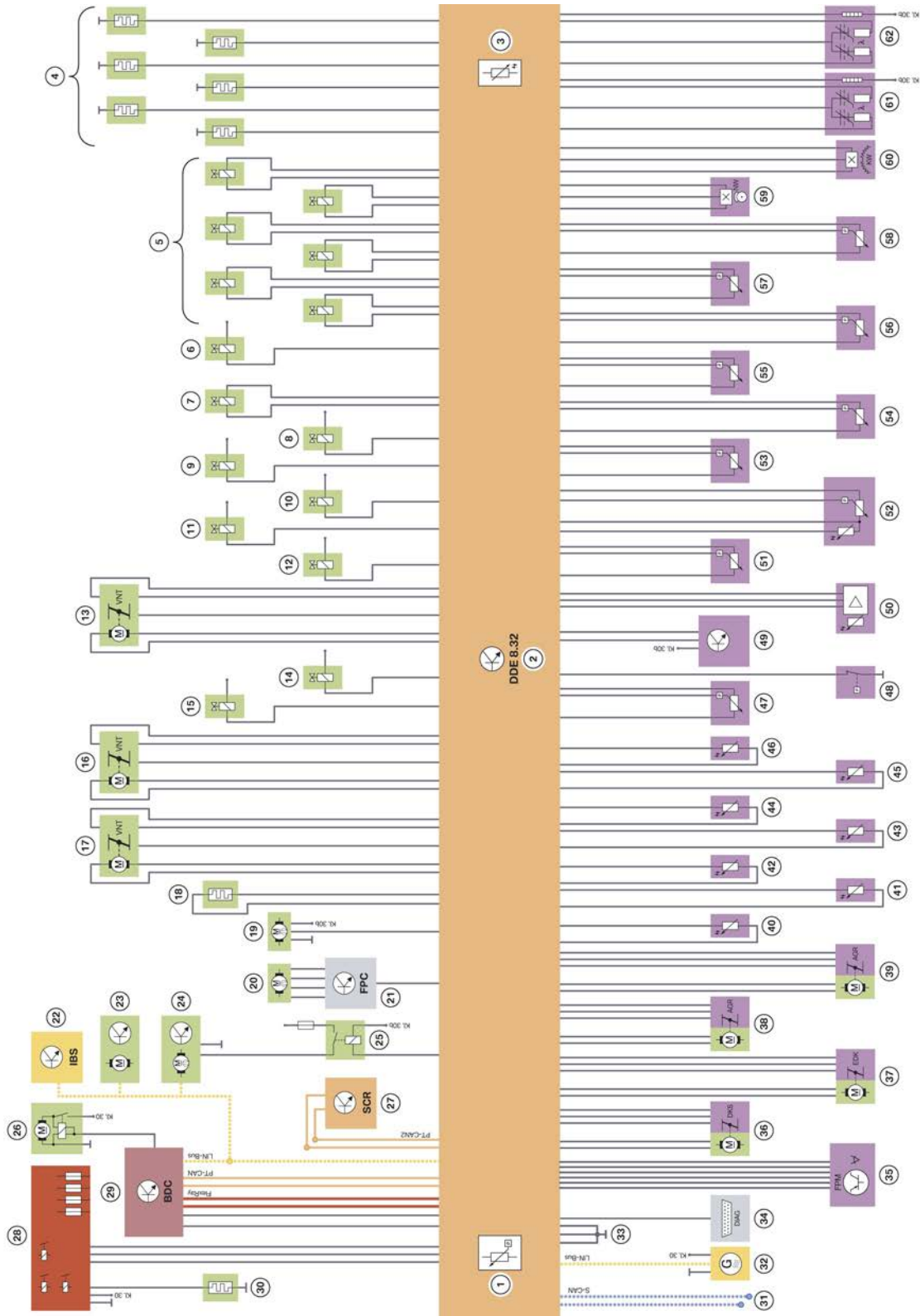

System wiring diagram for the B57 engine

# B57 Engine

## 9. Engine Electrical System

Index	Explanation
1	Ambient pressure sensor (internal control unit)
2	Digital Diesel Electronics (DDE 8.32)
3	Temperature sensor (internal control unit)
4	Glow plugs, cylinders 1–6
5	Injectors, cylinders 1–6
6	Fuel quantity control valve
7	Rail pressure regulating valve
8	Electric changeover valve for bypass flap of the high-pressure exhaust-gas recirculation cooler
9	Solenoid valve, piston cooling
10	Map-controlled valve, oil pump
11	Electric changeover valve for vacuum controlled engine mount
12	Electric changeover valve for the vacuum controlled coolant pump
13	Not used with B57D3000 engine
14	Not used with B57D3000 engine
15	Not used with B57D3000 engine
16	Not used with B57D3000 engine
17	Not used with B57D3000 engine
18	Blow-by-heating (OE for cold climate equipment specification)
19	Exhaust gas restriction flap
20	Electric fuel pump (three-phase current pump, low pressure circuit)
21	Fuel pump control module
22	Intelligent battery sensor
23	Active air-flap control
24	Electric fan
25	Relay for electric fan
26	Starter motor
27	SCR control unit
28	Integrated supply module
29	Body Domain Controller
30	Fuel filter, heating
31	Sensor CAN (NO <sub>x</sub> sensors, diesel particulate sensor)
32	Alternator
33	Ground connection
34	Diagnostic socket (OBD)

# B57 Engine

## 9. Engine Electrical System

<b>Index</b>	<b>Explanation</b>
35	Accelerator pedal module
36	Electrical swirl-flap controller with path feedback
37	Electromotive throttle controller with path feedback
38	High-pressure exhaust-gas recirculation valve with path feedback
39	Low-pressure exhaust-gas recirculation valve with path feedback
40	Exhaust temperature sensor upstream of catalytic converter near engine
41	Exhaust-gas temperature sensor upstream of diesel particulate filter
42	Exhaust temperature sensor downstream of high-pressure exhaust-gas recirculation
43	Exhaust temperature sensor downstream of low-pressure exhaust-gas recirculation
44	Exhaust temperature sensor upstream of SCR catalytic converter
45	Coolant temperature sensor
46	Charge-air temperature sensor
47	Oil pressure sensor
48	Oil pressure switch
49	Oil-level sensor (Puls 3)
50	Hot film air mass meter (HFM 8)
51	Combustion chamber pressure sensor
52	Fuel pressure sensor and fuel temperature sensor
53	Rail pressure sensor
54	Charging pressure sensor
55	Differential pressure sensor on the diesel particulate filter
56	Differential pressure sensor on low-pressure exhaust-gas recirculation module
57	Exhaust back-pressure sensor upstream of exhaust turbocharger
58	Not used with B57D3000 engine
59	Camshaft sensor
60	Crankshaft sensor
61	Broadband oxygen sensor upstream of catalytic converter near engine (LSU 5.1)
62	Broadband oxygen sensor downstream of diesel particulate filter (LSU 5.1)

# B57 Engine

## 9. Engine Electrical System

### 9.2. Digital Diesel Electronics

A new engine control unit generation from Bosch is used in the B57 engines. The 8th generation Digital Diesel Electronics (DDE) forms a joint control unit operating system for the gasoline and diesel engines. Its appearance is characterized by a uniform control unit housing as well as a uniform plug connector. The hardware is however adapted to the respective application area.

The Digital Diesel Electronics is the computing and controlling center of the engine management system. Sensors on the engine and the vehicle deliver the input signals and the actuators implement the commands. The Digital Diesel Electronics calculates the corresponding activation signals from the input signals, the computing models and characteristic maps stored.

The Digital Diesel Electronics also contains the gateway function between PT-CAN and PT-CAN2.

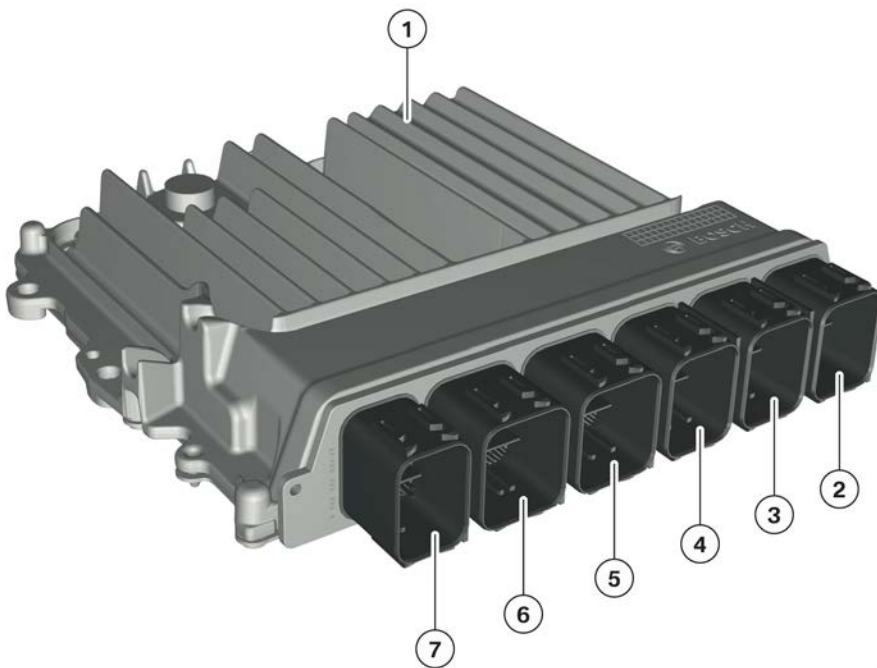

Digital Diesel Electronics DDE 8.32

Index	Explanation
1	Control unit Digital Diesel Electronics (DDE 8.32)
2	Module 100, vehicle connection, 54 pins
3	Module 200, sensors and actuators 1, 64 pins
4	Module 300, sensors and actuators 2, 64 pins
5	Module 400, preheating control, 24 pins
6	Module 500, DDE supply, 24 pins
7	Module 600, injection, 24 pins

# B57 Engine

## 9. Engine Electrical System

The Digital Diesel Electronics, DDE 8.32 has the following new features:

- Control unit operating system for gasoline and diesel engines
- Six modular plugs with a total of 254 pins
- Nano MQS plug-in contacts (Micro Quadlock System)
- Preheating control integrated in the Digital Diesel Electronics.

The short designation DDE 8.32 is explained in the following table:

Abbreviation Meaning	
DDE	Digital Diesel Electronics
8	Control unit generation
3	Common rail injection system with piezo injectors (even number = solenoid valve injector, odd number = piezo injector)
2	Hardware version

In the DDE control unit there are 2 sensors: a temperature sensor and an ambient pressure sensor. The temperature sensor monitors the components thermally. The ambient pressure is required for calculating the mixture composition.

Due to the use of the new nano MQS connector system, the space requirements on the printed circuit board could be greatly reduced. Five of the 6 modular plugs are fitted with the nano MQS plug-in contacts. Due to this, the wire cross-section could be reduced from 0.13 mm<sup>2</sup> to 0.35 mm<sup>2</sup>. This enables a weight reduction with a high resistance to vibration. Due to the installation space saved, the preheating control could be integrated into the Digital Diesel Electronics.

Further information on the nano MQS connector system can be found in the "ST1501 G12 Powertrain" Reference Manual.



**Measurements on the control unit may only be carried out using measuring procedures permitted by BMW. The use of incorrect tools, such as gauge tips, leads to damage to the plug-in contacts.**

**For repair work to the nano MQS plug-in contacts, please note the current repair instructions.**

### 9.3. Preheating system

The preheating control was integrated into the Digital Diesel Electronics 8.32 and controls the glow plugs temperature via the preheating wire harness. It contains a micro controller for the requirements-based control of the electrical power to the glow plug elements. The pulse-width modulated signal generated during this is output via power transistors.

To ensure the necessary glow element temperature, for example for vehicle voltage < 12 V, a preheating system with low-voltage technology is used.

# B57 Engine

## 9. Engine Electrical System

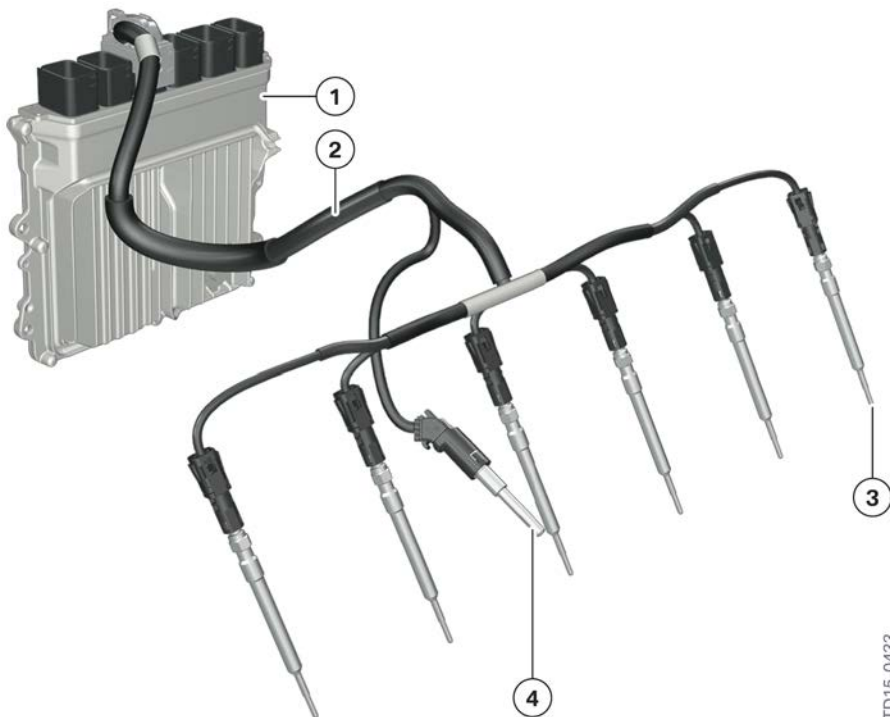

Preheating control, B57 engine

TD15-0433

Index	Explanation
1	Digital Diesel Electronics control unit
2	Preheating wire harness
3	Glow plugs
4	Combustion chamber pressure sensor

In the B57 engine **only** Bosch ceramic glow plugs with a nominal voltage of 7.0 V are used. These are of the same design used in the N57D3001 engine.

The activation of the safety data set and the following glow plug recognition is no longer required as only one type of glow element is used.

Following replacement of the glow plugs, only the service function "teach-in glow plugs" must be carried out.



**The ceramic glow plugs are sensitive to impact and bending loads. Glow plugs that have been dropped may have been exposed to damage.**

# B57 Engine

## 9. Engine Electrical System

### 9.4. Sensors

Common sensors and actuators are already familiar from the N57 engines and are therefore not described in detail in this documentation.

#### 9.4.1. Oil level sensor

In the B57 engine, a new oil-level sensor generation is used. It is the Puls 3 (Packaged Ultrasonic Level Sensor 3) oil-level sensor. The Puls 3 functions according to the ultrasound principle. The oil level is determined using a runtime measurement. The measuring range of the oil-level sensor is 18 mm to 118.8 mm. If there is temporary overfilling of the engine oil, the oil-level sensor is protected against penetration by the engine oil due to an air bubble in the cap area.

The sensor monitors the oil level through continual measurement when the engine has stopped (static measurement) and during engine operation (dynamic measurement). Within the oil-level sensor, the ultrasonic sensor, the engine oil temperature sensor and evaluation electronics are located next to each other in a housing (multi-chip module technology).

Marginal influences, such as the vehicle inclining, or lateral and longitudinal acceleration, are compensated by an averaging function in the Digital Diesel Electronics.

#### 9.4.2. Combustion chamber pressure sensor

The combustion chamber pressure monitoring enables combustion control by adapting the start of injection to the combustion chamber pressure process.

The B57 engine is equipped with a combustion chamber pressure sensor which is no longer located within the glow plugs, but is designed as an independent sensor. The sensor is screwed laterally into the cylinder head at the 4th cylinder. The combustion pressure acts upon the combustion chamber pressure sensor via a connection duct which ends in the glow plug duct.



# B57 Engine

## 9. Engine Electrical System

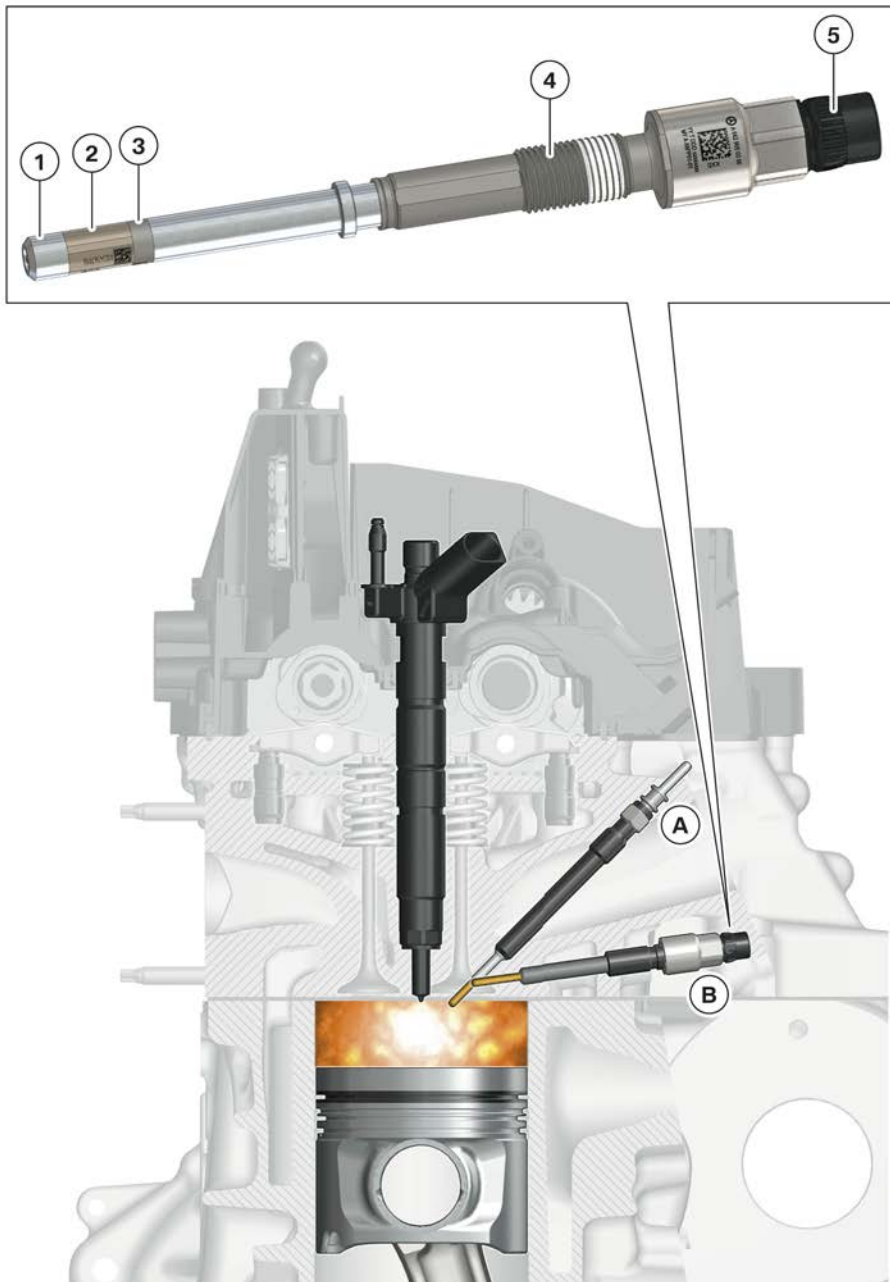

Combustion chamber pressure sensor, B57 engine

TD15-0434

# B57 Engine

## 9. Engine Electrical System

Index	Explanation
A	Glow plug
B	Combustion chamber pressure sensor
1	End cap with sealing diaphragm
2	Sensor element
3	Metal sealing ring
4	Thread
5	Electrical connection

The combustion chamber pressure is transferred to a piezoelectric element via a moveable pin. The sealing diaphragm enables pin movement and seals the sensor module in the combustion chamber pressure sensor against the combustion chamber pressure. The pin movement that results from the combustion pressure acts upon the piezo element. The pressure on the piezo element creates an electrical charge in the quartz crystal. The signal amplification and generation of signal voltage are done in the electronics module.

The sensor has 3 electrical connections:

- Positive and negative connection to the voltage supply
- Signal line for data transfer

Combustion control through the combustion chamber pressure sensor offers the following advantages:

- Reduction in the exhaust emissions
  - Particle matter
  - Nitrogen Oxide
- Lower fuel consumption
- Lower level of combustion noise
- Optimization of the power and the torque

The following table provides a comparison of the combustion chamber pressure sensors which are used in the BMW Bx7 engines:

	<b>B37 engine (Not US) CO<sub>2</sub> optimized</b>	<b>B47 Engine (Not US)</b>	<b>B57 engine</b>
Manufacturer	Beru	Bosch	Sensata
Sensor element	Strain gauge	Quartz crystal sensor element	Quartz crystal sensor element
Sensor design	Steel glow element with combustion chamber pressure sensor	Ceramic glow element with combustion chamber pressure sensor	Independent combustion chamber pressure sensor
Quantity	1	1	1

# B57 Engine

## 9. Engine Electrical System

	B37 engine (Not US) CO <sub>2</sub> optimized	B47 Engine (Not US)	B57 engine
Installation location	2nd cylinder	2nd cylinder	4th cylinder
Voltage	5 V	5 V	5 V
Signal voltage	0.5 - 4.5 V	0.5 - 4.5 V	0.5 - 4.5 V
Working area	0 - 200 bar	0 - 200 bar	0 - 220 bar
Maximum pressure	210 bar	250 bar	250 bar
Signal shape	Analog	Analog	Analog

**Note: Not all of the engines listed in the chart above are available currently for the US market; they are mentioned here for future reference and solely for comparison.**

### 9.4.3. Hot film air mass meter

The 8th generation Bosch hot film air mass meter is used in the B57 engine.

The air mass measurement serves to control the fuel injection rate and the exhaust-gas recirculation rate. In order to meet future, more stringent emissions threshold values, an increase in the signal precision of the air mass drawn in is required.

The sensor housing of the HFM 8 has been optimized aerodynamically by a new, smaller sensor element. A chip heating mode has been integrated to prevent dirt particles and oil mist deposits from forming on the sensor element during engine stops (also automatic engine start-stop function). These deposits can lead to measurement deviations.

#### Overview of hot film air mass meter

	Hot film air mass meter 6	Hot film air mass meter 7
Manufacturer	Bosch	Bosch
Sensor type	Hot film	Hot film
Voltage supply	12 V	12 V
Interface	Pulse width modulation signal	Pulse width modulation signal
Installed in	N57TU	N63TU, B38, B48
Connections	5 Voltage supply Earth Intake air temperature Reference voltage 5 V Air mass signal	4 Voltage supply Earth Intake air temperature Air mass signal

# B57 Engine

## 9. Engine Electrical System

	Hot film air mass meter M-P 5	Hot film air mass meter 8
Manufacturer	Continental	Bosch
Sensor type	Hot film	Hot film
Voltage supply	5 V	5 V
Interface	Pulse width modulation signal	SENT data protocol
Installed in	B37, B47, B47 Top	B57, B58, N63TU2
Connections	4 Voltage supply Earth Intake air temperature Air mass signal	3 Voltage supply Earth SENT data protocol

**Note: Not all of the engines listed in the chart above are available currently for the US market; they are mentioned here for future reference and solely for comparison.**

### SENT interface

Single Edge Nibble Transmission is a digital interface for point-to-point connections between a sensor and a control unit. Communication is unidirectional (in one direction).

In contrast to pulse-width-modulated transmission, signals on digital transmission paths cannot be distorted without recognition. Faults in transmission are recognized by the receiver via a checksum and the data is marked as invalid. Due to its simplicity, the SENT protocol is resistant to fault signals.

For pulse-width modulated signals, the data is encoded by low and high levels which correspond to a particular value. SENT, however, is a digital transmission process in which the information is between two negative flanks for the duration. It is not the entire pulse which is used for detection, but just the voltage drop i.e. "Single Edge". Four bit values (e.g. 0110) are always transmitted between 2 negative flanks and are called a nibble.

The various information only differs by short differences in pulse length in the  $\mu\text{s}$  range.

After a synchronization pulse, a total of 8 nibbles follow:

- Status nibble
- 6 data nibbles
  - 3 data nibbles (e.g. air mass)
  - 3 data nibbles (e.g. intake air temperature)
- Checksum nibble

# B57 Engine

## 9. Engine Electrical System



A comparison of air mass signal pulse-width modulation and SENT

TD15-0499

# B57 Engine

## 9. Engine Electrical System

Index	Explanation
A	Pulse-width modulated signal
B	SENT protocol
1	Duty cycle
2	Signal length
3	Synchronization pulse
4	Status signal
5	Data record 1
6	Data record 2
7	Checksum comparison
8	Pause pulse to separate the messages

### 9.4.4. Diesel particulate sensor (only US version)

As with the N47TU and the N57TU engines in the US market, the B57 also uses a diesel particulate sensor or “soot sensor” to monitor the efficiency of the diesel particulate filter.

The diesel particulate filter is an essential component in the exhaust re-treatment of all current BMW diesel engines. Monitoring and diagnosis of the diesel particulate filter is mandatory in order to guarantee its operation.

Although the differential pressure measurement is not only used to determine the load status of the diesel particulate filter; the manipulation of or a fault at the diesel particulate filter structure can be recognized from counter-pressure in the diesel particulate filter being too low. Due to the more stringent OBD (On-Board Diagnostics) limit values, the differential pressure measurement alone is no longer sufficient, as the number of particles is also subject to a limit value.

In order to increase the precision of the diesel particulate filter diagnosis, the diesel particulate sensor is used. The number of particles after the diesel particulate filter can therefore be determined very precisely.

The diesel particulate sensor is located downstream of the SCR catalytic converter in the exhaust pipe. Here, the sensor is sufficiently protected from the hot exhaust gases and the AdBlue of the SCR system.

# B57 Engine

## 9. Engine Electrical System

### Design

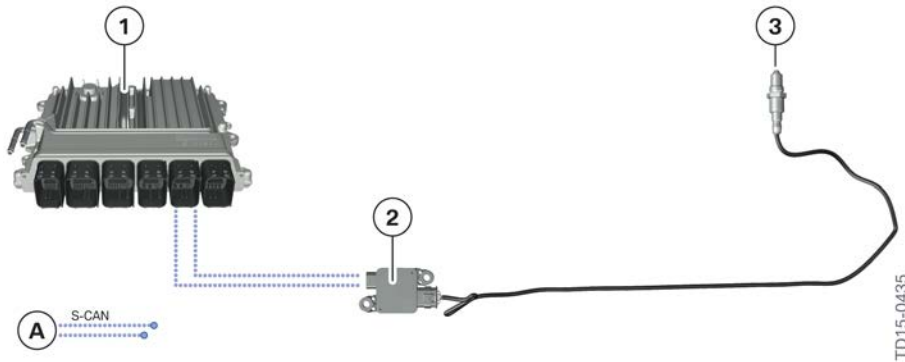

Overview of the diesel particulate sensor, B57 engine

Index	Explanation
A	Sensor CAN
1	Digital Diesel Electronics (DDE 8.32)
2	Evaluation electronics
3	Measuring probe

The diesel particulate sensor communicates with the Digital Diesel Electronics via the Sensor CAN and is composed of evaluation electronics and the measuring probe. The evaluation electronics generates the output signal using the measured sensor values.

The sensor is integrated into the exhaust pipe in such a way that the sensor inlet opening is located in the middle of the exhaust flow. This is the optimum positioning to record the particle content of the exhaust gas. The particles are directed to the sensor element via a measuring tube integrated into the measuring probe.

The sensor element consists of insulating aluminium nitride ceramic and is printed on the one side with the sensor electrode pattern made from platinum. On the other side there is the heating element to regenerate the sensor element. The heater circuit is very similar to the heating circuit of an oxygen sensor and it is powered by 12 volts. The sensing element circuit is supplied a 5V reference which is evaluated by the DDE by monitoring the resistance and calculating the current across the electrodes.

# B57 Engine

## 9. Engine Electrical System

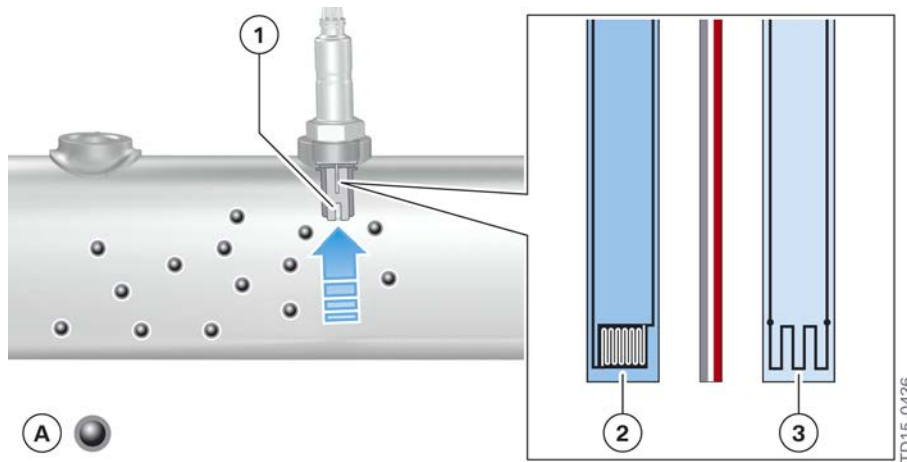

Design of the diesel particulate sensor

Index	Explanation
A	Soot particle
1	Measuring tube
2	Sensor element
3	Heating element

### Operating principle

The operation of the soot sensor is based on resistance measurement. A voltage of 5 V is applied to the electrodes of the sensor element via the evaluation electronics. The initial resistance of the sensor changes as the sensing element collects soot to make a measurement. Before and after the measurement phase the soot particles must be removed and the resistance of the sensor element must be returned to its pre-measurement value. This is achieved by heating the element with the internal heater. The soot is burned off in the regeneration process and the initial resistance of the sensing element is once again restored. The sensor is now ready for another sampling event. This sensing and regeneration cycle runs continually through the operation of the sensor.

After the "dew point" is reached, an initial regeneration process takes place designed to restore the initial resistance of the sensing element. As soot begins to accumulate on the sensing element the measurement of the soot particles begins. If the exhaust temperature is below the dew point temperature, water vapor condensation is possible; this could damage the diesel particulate sensor.

The electrically conductive soot particles are deposited on the sensor element between the electrodes and form conductive paths there. Due to the change to the electrode structure, the initial resistance at the electrodes decreases and the current level increases.



# B57 Engine

## 9. Engine Electrical System

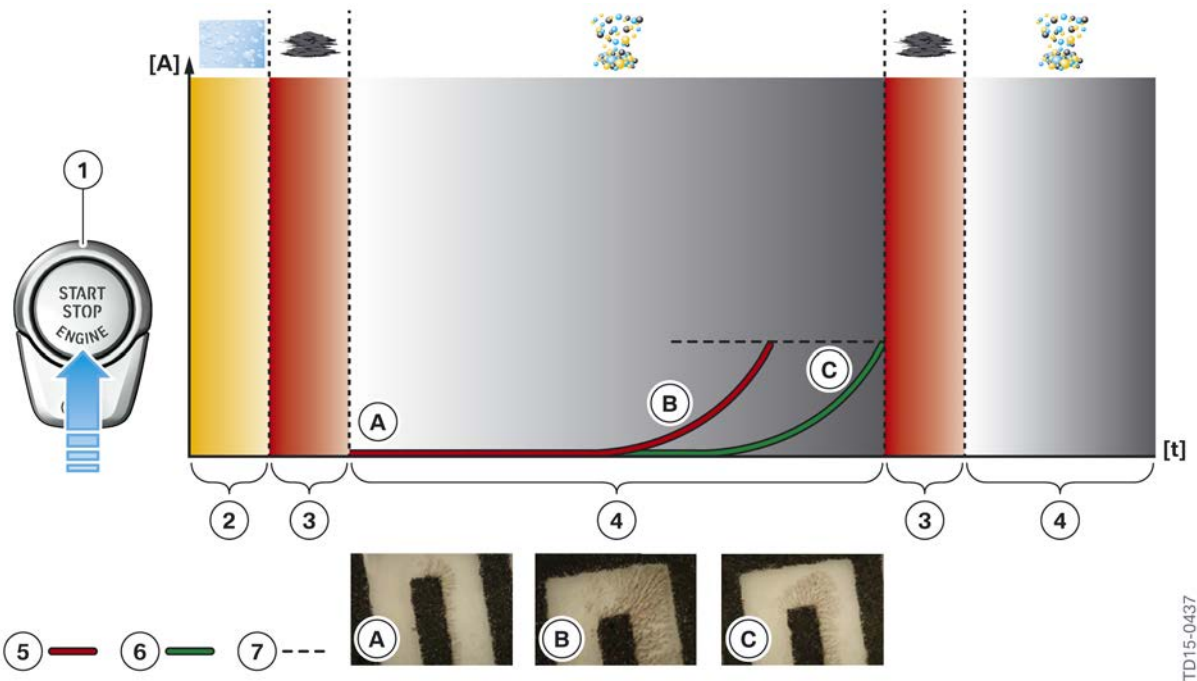

TD15-0437

Schematic diagram of a measuring cycle in diesel particulate filter monitoring

Index	Explanation
A	Start of measuring cycle
B	High level of soot particles in exhaust gas (DPF Test failed)
C	Low level of soot particles in exhaust gas (DPF Test passed)
[A]	Ampere
[t]	Time period
1	Engine start
2	Dew point phase
3	Regeneration phase
4	Measurement phase
5	Diesel particulate filter test failed
6	Diesel particulate filter test passed
7	Threshold set-point value

The evaluation electronics monitors the current level and forwards on the measured values to the Digital Diesel Electronics. The Digital Diesel Electronics compares the time period of the increase in current with a saved threshold set-point value and, using these values, can assess the functioning of the diesel particulate filter. If the threshold value is reached in under a stipulated time period, then the measurement has not passed.

# B57 Engine

## 9. Engine Electrical System

The sensor element gradually collects soot particles, this lowers the resistance across the electrodes which causes an increase of the measured current. The PM sensor evaluation electronics control unit monitors the current level and forwards on the measured values to the Digital Diesel Electronics via the S-CAN. The DDE compares the time period of the increase in current with a saved threshold set-point value and, using these values, can assess the operation of the diesel particulate filter. If the threshold value is reached in under a stipulated time period, then the measurement has not passed and the DPF has failed the test. A fault code entry is set in the Digital Diesel Electronics and the malfunction indicator lamp in the instrument cluster shows an emission-relevant fault.

At the end of the measurement, the deposited soot particles must be burned off. This is necessary to recreate the initial resistance of the sensor element. The burning off is carried out by the heating element. Through the regeneration, the measured values are reset and another measurement is started.



---

**The evaluation electronics and measuring probe cannot be replaced separately.**

**After replacing the diesel particulate sensor, the adaptation values must be reset via ISTA (BMW diagnosis system).**

---

### 9.5. Exhaust emission system

To meet the strict EURO 6 exhaust emission standards in ECE and the ever so stringent US emission regulations, all BMW diesel engines use a 3rd generation SCR (Selective Catalytic Reduction) system as well as high-pressure and low-pressure exhaust-gas recirculation (EGR).

Systems	G30 540d xDrive
Low-pressure exhaust-gas recirculation	●
High-pressure exhaust-gas recirculation	●
Exhaust gas restriction flap	●
Nitrogen oxide storage catalytic converter (NSC)	●
Oxidation catalytic converter	●
Selective Catalytic Reduction (SCR)	●
SCR 2-tank system	●
Diesel Particulate Filter (DPF)	●
Diesel particulate matter sensor (US)	●

The following graphic shows the exhaust emission system on the diesel engines with the corresponding actuators and sensors.

# B57 Engine

## 9. Engine Electrical System

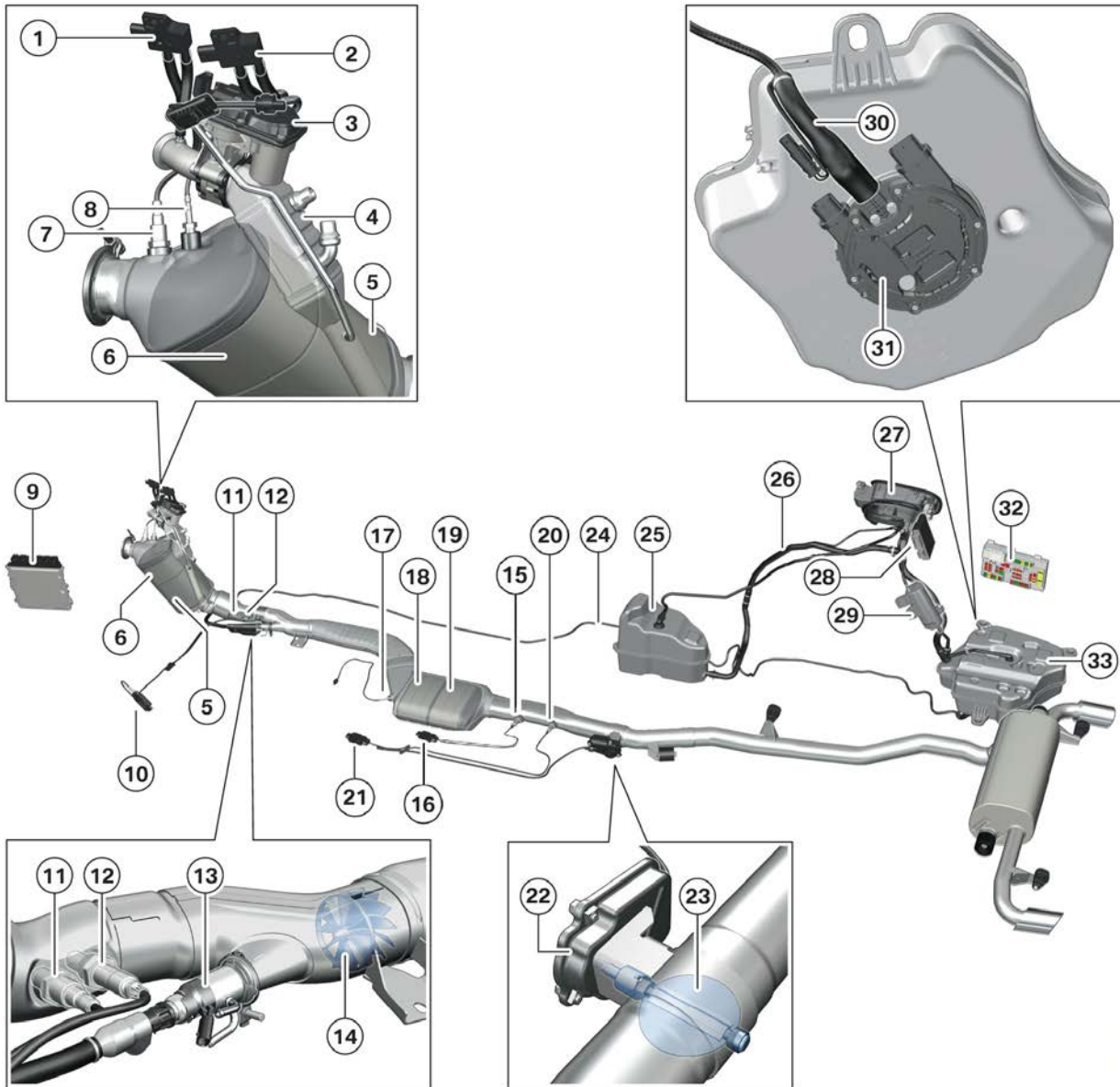

Overview of the B57 engine's exhaust re-treatment in the G30

TA16-0542-2

Index	Explanation
1	Differential pressure sensor for low-pressure exhaust gas recirculation module
2	Differential pressure sensor for diesel particulate filter
3	Exhaust-gas recirculation valve, low-pressure EGR
4	Coolant-cooled low-pressure exhaust gas recirculation module
5	Diesel particulate filter
6	Nitrogen oxide catalytic converter
7	Broadband oxygen sensor
8	Exhaust-gas temperature sensor

# B57 Engine

## 9. Engine Electrical System

Index	Explanation
9	Digital Diesel Electronics (DDE)
10	Nitrogen oxide sensor control unit
11	Broadband oxygen sensor (LSU 5.1)
12	Nitrogen oxide sensor
13	Metering module
14	Mixer
15	Particulate matter sensor (soot sensor)
16	Particulate matter sensor control unit
17	Exhaust-gas temperature sensor
18	SCR catalytic converter 1
19	SCR catalytic converter 2
20	Nitrogen oxide sensor
21	Nitrogen oxide sensor control unit
22	Electrical actuator for exhaust gas restriction flap
23	Exhaust gas restriction flap
24	Metering line with heating
25	SCR passive tank (8.5 l)
26	Urea/water mixture filler tube
27	Fuel filler cap
28	SCR control unit
29	Bubble container
30	Heating
31	Tank flange module
32	Rear right power distribution box
33	SCR active tank (12.5 l)

### 9.5.1. High- and low-pressure exhaust-gas recirculation

Nitrogen Oxides ( $\text{NO}_x$ ) are a by-product of the chemical and thermal reactions between oxygen and nitrogen in the combustion of hydrocarbons. Therefore  $\text{NO}_x$  production (in the cylinder) is directly related to combustion peak temperatures that accelerate these reactions. Exhaust-gas recirculation is an internal engine measure for reduction of Nitrogen Oxides ( $\text{NO}_x$ ). In this process, a defined quantity of (inert) exhaust gas corresponding to the operating condition is mixed with the fresh air entering the engine. As the gas is inert; it takes up space otherwise occupied by oxygen in the combustion chamber. The less oxygen that is available to react with the nitrogen and the lower peak combustion temperatures combine to reduce the production of  $\text{NO}_x$ .

# B57 Engine

## 9. Engine Electrical System

The following graphic contains a schematic illustration of the design of the exhaust-gas recirculation systems without the corresponding sensors.

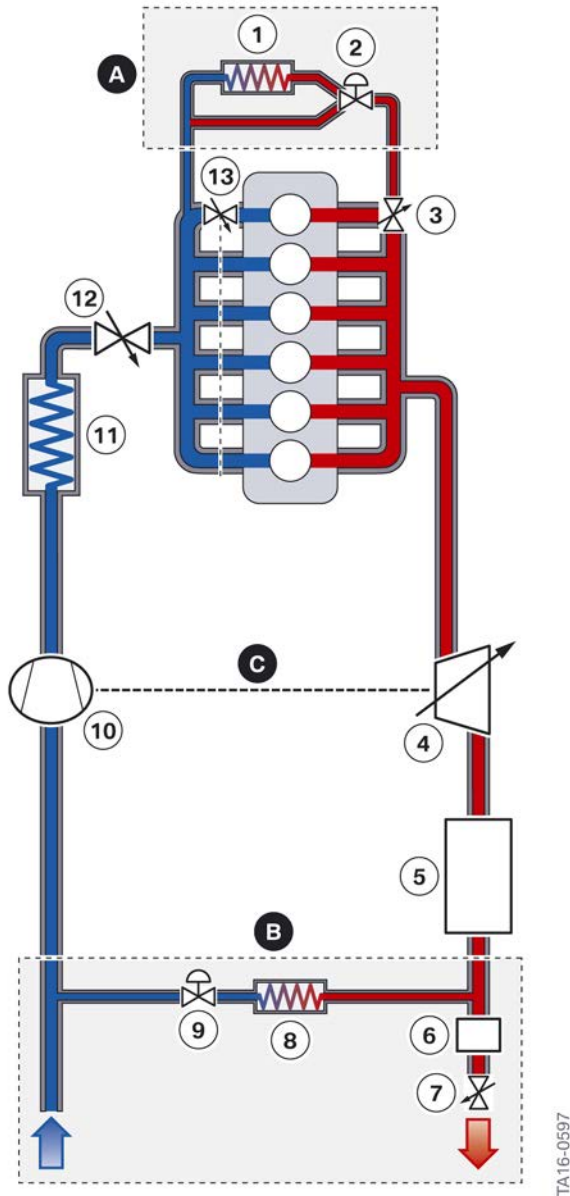

Schematic diagram of high- and low-pressure exhaust-gas recirculation for Bx7 engine in the G30

Index	Explanation
A	High-pressure exhaust-gas recirculation
B	Low-pressure exhaust-gas recirculation
C	Exhaust turbocharger
1	Exhaust-gas recirculation cooler, high-pressure EGR
2	Bypass valve, exhaust-gas recirculation cooler, high-pressure EGR

# B57 Engine

## 9. Engine Electrical System

Index	Explanation
3	Exhaust-gas recirculation valve, high-pressure EGR
4	Controller, variable turbine geometry
5	NO <sub>x</sub> storage converter and diesel particulate filter
6	Selective Catalytic Reduction catalytic converter (SCR catalytic converter)
7	Exhaust gas restriction flap
8	Exhaust-gas recirculation cooler, low-pressure EGR
9	Exhaust-gas recirculation valve, low-pressure EGR
10	Compressor exhaust turbocharger
11	Charge air cooler
12	Throttle valve
13	Swirl-flap actuator

### 9.5.2. Diesel particulate filter regeneration

The diesel particulate filter has a limited soot loading capacity and must be regenerated regularly. This is why the Digital Diesel Electronics (DDE) determines the charge state of the diesel particulate filter. The regeneration process starts after a predetermined soot loading limit is reached.

The start of regeneration depends on the following parameters:

- Differential pressure in the diesel particulate filter
- Driving profile since the last regeneration

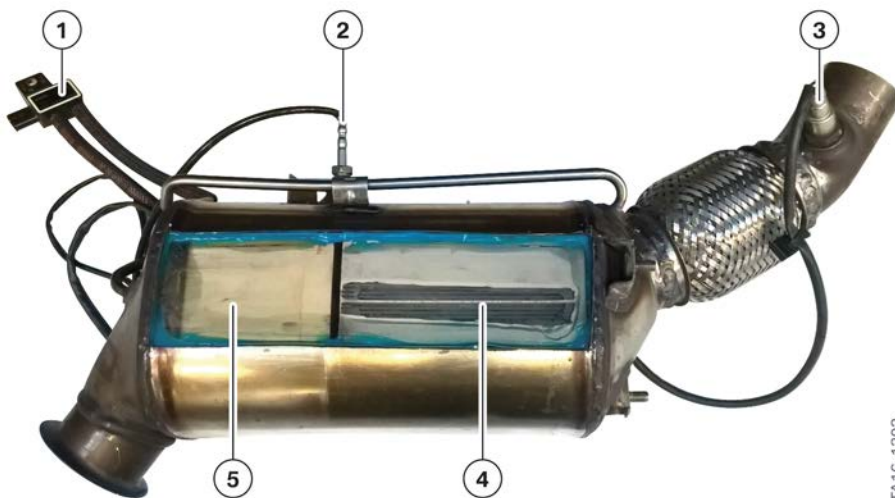

Cut away view of the Diesel particulate filter (B47 engine)

TA16-1303

# B57 Engine

## 9. Engine Electrical System

Index	Explanation
1	Differential pressure sensor
2	Temperature sensor
3	Oxygen sensor
4	Diesel particulate filter
5	Nitrogen oxide catalytic converter

In order to oxidize the soot collected on the inside of the diesel particulate filter, the exhaust-gas temperature must be raised to about 580 °C (1076 °F). To be able to safely reach the exhaust temperature in all marginal conditions, temperature actions are integrated into the Digital Diesel Electronics (DDE).

### Parameters for regeneration of the diesel particulate filter

The following information is referenced for regenerating the diesel particulate filter:

- Air mass signal
- Coolant temperature
- Crankshaft sensor signal
- Intake air temperature
- Ambient pressure
- Charging pressure
- Differential pressure in the diesel particulate filter
- Fuel pressure sensor
- Gear sensor
- Exhaust-gas temperature sensor
- Speed signal
- Fuel quantity

### Computation of soot load

The diesel particulate filter is equipped with a differential pressure sensor which constantly monitors the existing pressure difference. The soot load in the diesel particulate filter is calculated from the differential pressure and the calculated exhaust gas mass flow.

The following input data is reference for calculating the soot load:

- Exhaust gas mass flow  
Calculated from the measured air mass flow, the exhaust gas recirculation rate and the fuel injection rate.
- Exhaust-gas temperature upstream of diesel particulate filter.
- Absolute internal pressure in the diesel particulate filter  
Calculated from the pressure loss model in the exhaust emission system, the ambient pressure and the differential pressure.

# B57 Engine

## 9. Engine Electrical System

### **Analysis of the driving profile since the last regeneration**

The Digital Diesel Electronics (DDE) monitors the distance travelled since the last regeneration. A maximum distance travelled at which regeneration is activated is computed from the driving profile.

The following input data is reference for calculating the distance travelled:

- Average driving speed since the last regeneration
- Average length of the driving cycles since the last regeneration

### **Regeneration phases**

Diesel particulate filter regeneration consists of two phases:

- Heating up the system
- Regenerating the system

Once regeneration is active, engine operation changes to heat up the system. After reaching a coolant temperature of about 60 °C (140 °F), regeneration is triggered.

### **Heating up the diesel particulate filter**

To heat up the diesel particulate filter, the air mass taken in is reduced, and the combustion focus is retarded.

The following parameters are used for heating up:

- Air mass
- Exhaust-gas recirculation rate
- Charging pressure
- Quantity and time of main and post-injection
- Air swirl in the combustion chamber

On reaching an exhaust temperature of around >400 °C (752 °F), a transition from heat up to regeneration takes place.



# B57 Engine

## 9. Engine Electrical System

### Diesel particulate filter regeneration

During the regeneration, the exhaust temperature continues to increase up to 580 °C (1076 °F). This increase is achieved by continuing to reduce the air mass taken in, and retarding the combustion once again.

The following parameters are adapted during regeneration:

- 1 Air mass**  
The set-point value of the air mass is computed by reference to the engine speed and the fuel injection rate. Depending on the ambient pressure, the set-point value is adapted to achieve stable combustion at various altitudes.
- 2 Exhaust-gas recirculation rate**  
The desired exhaust-gas recirculation rate is computed as a function of the engine speed and the fuel injection rate. Depending on the ambient pressure and the intake air temperature, the set-point value is adapted so that stable combustion is achieved at various altitudes and low ambient temperatures.
- 3 Charging pressure**  
The desired charging pressure is also computed as a function of the engine speed and the fuel injection rate. The charging pressure set-point value is formed as a function of the ambient pressure and the intake air temperature so that stable combustion is possible at a low ambient temperature, and the maximum exhaust gas turbocharger speed is not exceeded.
- 4 Fuel injection pressure**  
The desired fuel injection pressure depends on the engine speed and fuel injection rate.
- 5 Air swirl in the combustion chamber**  
The set-point value of the swirl flap is also computed as a function of the engine speed and the fuel injection rate.
- 6 Quantity and time of main and post-injection**  
If the ambient pressure is low, adaptations occur to ensure that the maximum temperature load for the exhaust turbocharger is not exceeded.

### Switch-off strategy for regeneration

Regeneration is only possible within the defined range of coolant temperature, exhaust temperature and ambient pressure. This is why regeneration has no influence on the exhaust tailpipe exhaust gas emissions.

The regeneration cut-off limits are defined as follows:

- 1 Coolant temperature of around >60 °C (140 °F) to <110 °C (230 °F)**  
The bottom temperature limit is necessary to ensure stable combustion. The top temperature limit protects the engine against thermal destruction.
- 2 Exhaust temperature of around >220 °C (428 °F) to <690 °C (1274 °F)**  
The lower temperature limit is necessary to ensure a sufficient exothermal reaction in the diesel particulate filter. The top temperature limit protects the diesel particulate filter against thermal destruction.
- 3 Ambient pressure >600 hPa**  
At lower ambient pressures, the maximum permissible exhaust gas turbocharger speed is exceeded; regeneration is blocked for this reason.

# B57 Engine

## 9. Engine Electrical System

### 9.5.3. Diesel particulate filter cleaning

The charge capacity of the diesel particulate filter is limited. For this reason, it is cleaned at regular intervals through regeneration. Regeneration is triggered and monitored by the Digital Diesel Electronics (DDE). During this process, the intake air is choked, the total injection rate increased, the main injection retarded in the direction of late, an additional post-injection is generated and various consumers are activated to increase the load (e.g. preheating system).

An unfavorable driving profile can lead to an increased load in the diesel particulate filter. If the coolant temperature required for regeneration is not reached, this is either attributable to the customer's driving profile, or to a component defect of the vehicle. If the diesel particulate filter is overloaded, cyclical regeneration is not released by the DDE (regeneration lock).

If this occurs, then a chemical regeneration aid for the particulate filter can be useful. To do this, you need to precisely follow the current repair instructions "Cleaning the diesel particulate filter".

If the diesel particulate filter is fully loaded with ash (non-flammable minerals) due to high mileage, and if the back pressure is too high due to this, then the described "Diesel particle filter cleaning" is **not** meaningful.

The diesel particulate filter cleaning agent needs to be sprayed into the diesel particulate filter via the differential pressure sensor line as described in the repair instructions. The cleaning agent distributes the local soot load across the entire volume of the filter. This increases the flow rate and reduces the differential pressure. Once the DDE detects the reduced differential pressure, it releases the regeneration process.



**When filling the diesel particulate filter with the cleaning agent, make sure that the differential pressure sensors on the high- and low-pressure exhaust-gas recirculation are not swapped.**

Pressure cup spray gun



Lance



DPF cleaning agent



# B57 Engine

## 9. Engine Electrical System

The cleaning agent and the matching special tool are available as the following part numbers:

Special tools	Part number
Starter kit diesel particulate filter cleaning agent Pressure cup spray gun + lance + 6 x 500 ml cleaning agent	83 19 2 211 603
Diesel particulate filter cleaning agent 1 x 500 ml	83 19 2 211 602



The cleaning agent may only be applied to the cooled down engine.

The diesel particulate filter should be "luke-warm" at the most to ensure the best cleaning results.

Use only the pressure cup spray gun provided.

Operate the pressure cup spray gun at a maximum of two bar.

After filling the diesel particulate filter with the cleaning agent it is necessary to drive the vehicle for about 30 minutes, preferably at a constant speed. Then carry out the service function "Diesel particulate filter regeneration" once again. In the case of the Bx7 engines, the regeneration requested via the service function can be performed while stationary. The vehicle fault, or the customer complaint then needs to be re-assessed.



**When regenerating the diesel particulate filter while stationary (service function "Diesel particulate filter regeneration"), note that very high temperatures occur in the area of the exhaust system. Trapped heat at the rear bumper can cause damage, for example. When using exhaust gas hoses, the hoses must be heat-resistant. The notes in the repair instructions must be followed.**



**Multiple application of chemical cleaning can cause permanent damage to the filter ceramics. For this reason, this method is only permitted once.**

**The cleaning operation must always be documented in the Service Booklet and the vehicle records.**



**The pressure cup spray gun must be thoroughly cleaned with water after use.**

# B57 Engine

## 9. Engine Electrical System

### 9.6. BMW models (US) with SCR technology

The following table provides an overview of which SCR generation is used in which models.

Series	Model	Engine	Standard	SCR	Active tank	Passive tank	SOP
E70	X5 xDrive35d	M57D30T2	NEDC	SCR 1	6.4 L	16.5 L	09/11
E90	335d	M57D30T2	NEDC	SCR 1	7.4 L	14.4 L	09/11
F10 LCI	535xd	N57D30O1	NEDC	SCR 2	15 L	—	07/13
F02 LCI	740xd	N57D30O1	NEDC	SCR 2	15 L	—	07/13
F15	X5 xDrive40d	N57D30O1	NEDC	SCR 2	13.7 L	15.3 L	9/13
F30, F31	328xd	B47D20O1	NEDC	SCR 2	8.7 L	9.4 L	07/13
G30	530d	B57D30O0	RDE	SCR 3	12.5 L	8.5 L	7/17







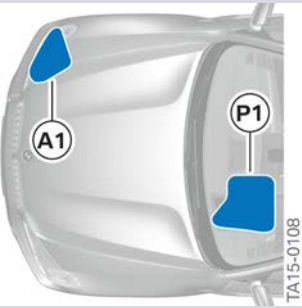
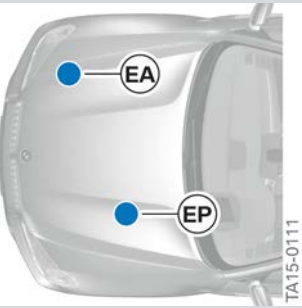

NEDC = New European Driving Cycle

RDE = Real Driving Emission driving cycle

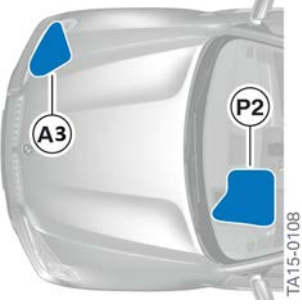
# B57 Engine

## 9. Engine Electrical System

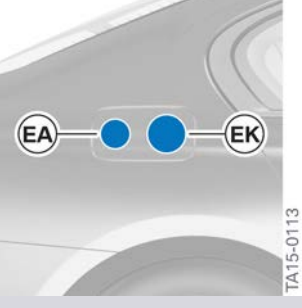
### 9.6.1. Installation locations of SCR components (US only)

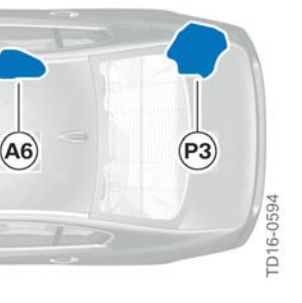
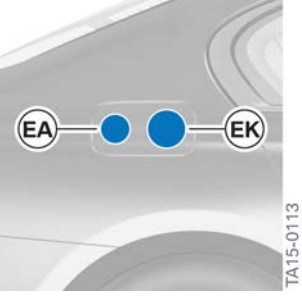
Models	Installation location of SCR control unit	Installation location of SCR tank	Installation location of SCR filler neck
E70 (SCR 1)	 TA15-0104	 TA15-0108	 TA15-0111
F15 (SCR 2)	 TD16-0934	 TA15-0108	 TA15-0112_2
F02, F10 single- branch (SCR 2)	 TA15-0103	 TA15-0106	 TA15-0113
F30, F31 two- branch (SCR 2)	 TA15-0103	 TD16-0594	 TA15-0113

# B57 Engine

## 9. Engine Electrical System

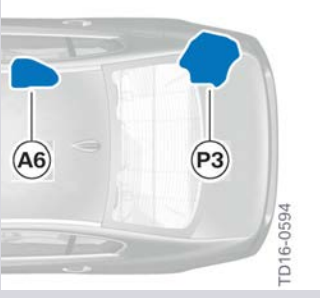
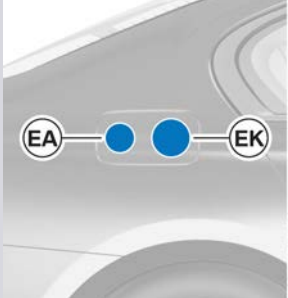
Models	Installation location of SCR control unit	Installation location of SCR tank	Installation location of SCR filler neck
F30, F31 two-branch (SCR 2)	 TA15-0103	 TD16-0594	 TA15-0113

Index	Explanation
S1	Rear SCR control unit
S2	Front SCR control unit
S3	DDE control unit (with integrated SCR control unit)
A1	Active tank version 1 with 6.4 l (E70)
A3	Active tank version 3 with 13.7 l (F15)
A4	Active tank version 4 with 15 l (F10, F02)
A6	Active tank version 6 with 8.7 l (F30, F31)
A7	Active tank version 7 with 12,5 l (G30)
P1	Passive tank version 1 with 16.5 l (E70)
P2	Passive tank version 2 with 15.3 l (F15)
P3	Passive tank version 3 with 9.4 l (F33, F31)
P4	Passive tank version 4 with 8.5 l (G30)
EA	Filler neck, active tank
EP	Filler neck, passive tank
EK	Filler neck, fuel tank

# B57 Engine

## 9. Engine Electrical System

### 9.6.2. Differences in the system technology

	<b>SCR 1</b>	<b>SCR 2</b>	<b>SCR 3</b>
SCR control	DDE	SCR control unit	SCR control unit
SCR strategy	DDE	DDE	DDE
Filling level sensor, passive tank	Sensor (selective)	Ultrasonic (continuous)	Ultrasonic (continuous)
Filling level sensor, active tank	Sensor (selective)	Ultrasonic (continuous)	- Piezo element (quality sensor) - Ultrasonic sound (continuous)
Pressure sensing	Pressure sensor	Computational model	Pressure sensor
Discharge hole	Yes	No	No
Coolant-cooled SCR metering module	No	Yes	Yes
Quality sensor urea/water mixture (AdBlue®)	No	No	Yes
Filler connections	2	1 (2 in F15)	1
System supplier	Bosch	Bosch	Continental

# B57 Engine

## 10. SCR 3

### 10.1. Overview

Selective Catalytic Reduction 3 (as the name implies) is the third generation of the SCR system used by BMW. The urea/water mixture (AdBlue®) is carried in the vehicle in one or two tanks, depending on the model. The BMW 5 Series Diesel (G30) uses a two tank system. This ensures sufficient volume to guarantee a high range for the NO<sub>x</sub> emission control system.

The following graphic shows a **simplified** schematic diagram of the system:

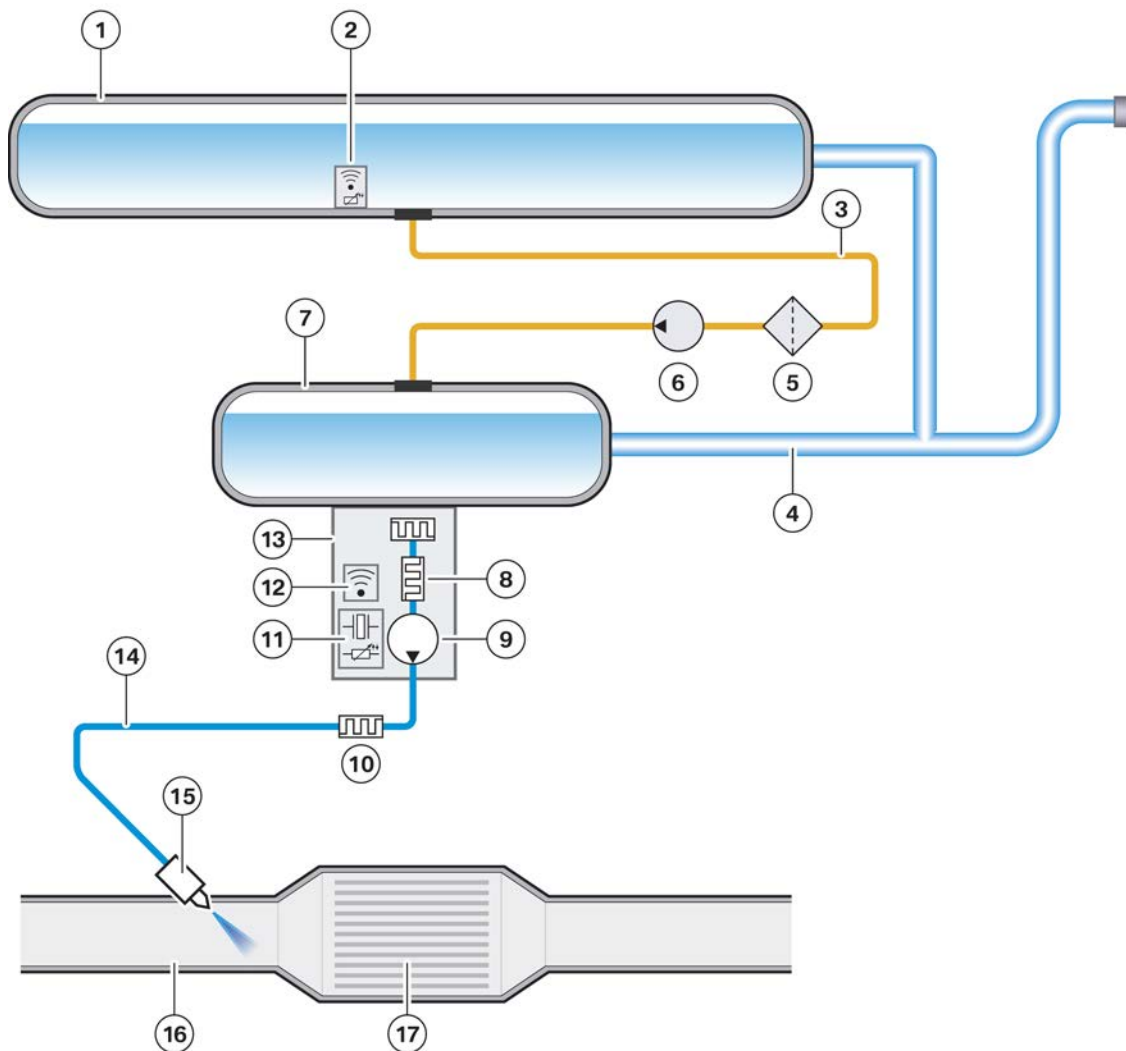

SCR 3, simplified schematic diagram of the SCR system based on the example of the G30

TD16-0569

Index	Explanation
1	Passive tank
2	Tank flange with level sensor and temperature sensor — passive tank
3	Transfer line
4	Filler connection



# B57 Engine

## 10. SCR 3

Index	Explanation
5	Fine filter
6	Recirculating pump unit
7	Active tank
8	Heating active tank and tank flange module
9	Pump
10	Heating metering line
11	Filling level sensor/urea/water mixture (AdBlue®) quality sensor and temperature sensor active tank
12	Fuel level sensor
13	Tank flange module active tank
14	Metering line
15	Metering valve
16	Exhaust system
17	SCR catalytic converter

The reason why two SCR tanks are used (depending on the series) is that different installation areas are available due to the packaging space. This allows for the necessary volumes to be transported, in order to guarantee the required top-up intervals for covering long distances between refilling.

Because the urea/water mixture (AdBlue®) freezes at -11 °C (12.2 °F), the active tank needs to be heated. The passive tank however does not use heating. This saves energy, by not having to heat the entire volume of the urea/water mixture (AdBlue®).

The urea/water mixture (AdBlue®) is delivered from the active tank to the SCR metering module via the metering line which is also heated.

Because the passive tank is not heated; the recirculating pump unit regularly ensures that the urea/water mixture (AdBlue®) is pumped from the passive tank to the active tank.

Although some current BMW models may use just one tank (active) this training material partly describes and illustrates the (G30 with the B57 engine for the US market) system version with two tanks. The functions are generally identical in the version with one tank. The additional components required for a two-tank system can be dropped for a single-tank system.

# B57 Engine

## 10. SCR 3

### 10.1.1. Installation locations

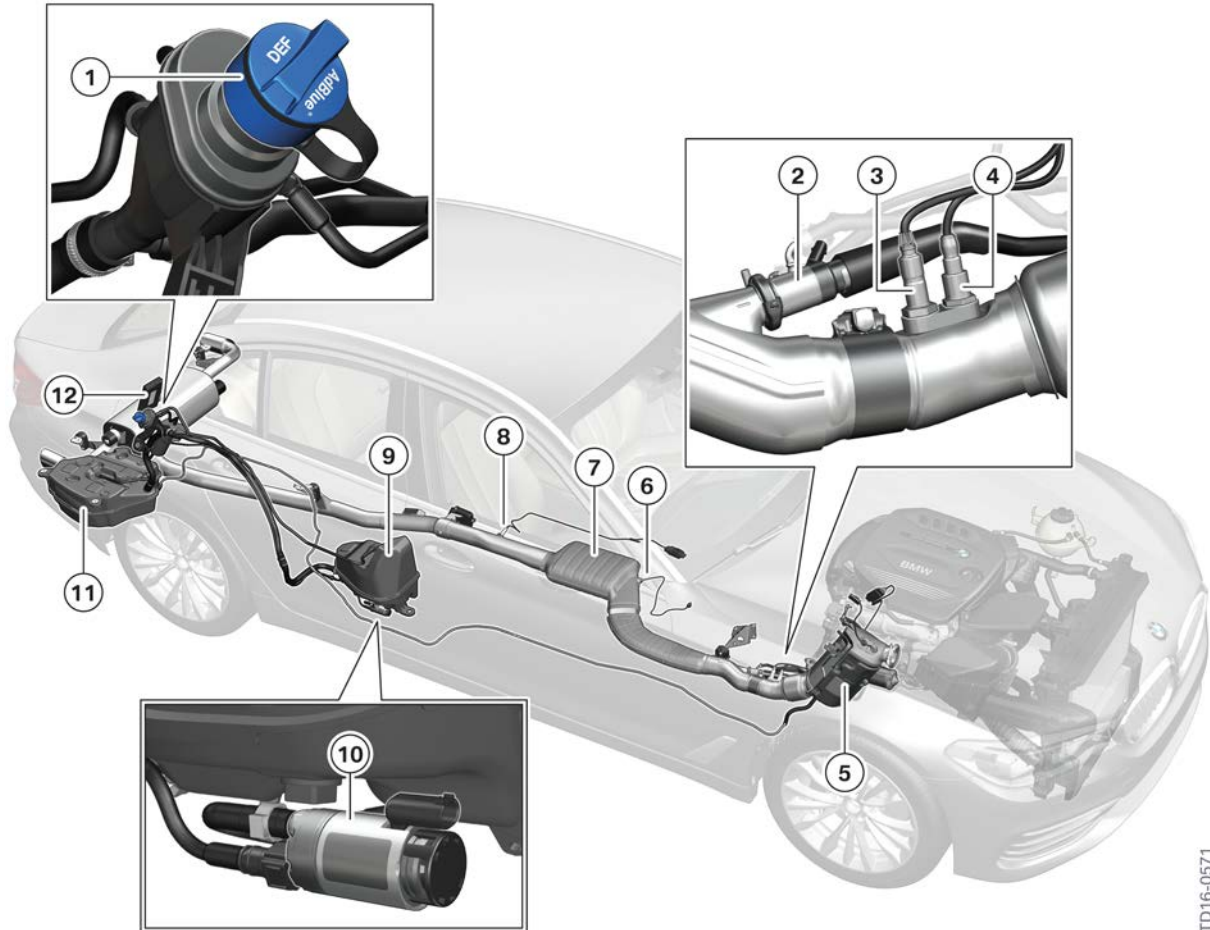

Installation locations of SCR 3 components using on the G30

TD16-0571

Index	Explanation
1	Urea/water mixture (AdBlue®), filler connection with fluid filler cap
2	Metering module
3	NO <sub>x</sub> sensor before the SCR catalytic converter
4	Oxygen sensor
5	NO <sub>x</sub> storage catalytic converter and diesel particulate filter
6	Exhaust-gas temperature sensor after diesel particulate filter
7	SCR catalytic converter
8	NO <sub>x</sub> sensor after SCR catalytic converter

# B57 Engine

## 10. SCR 3

<b>Index</b>	<b>Explanation</b>
9	Passive tank
10	Recirculating pump unit
11	Active tank
12	SCR control unit

The G30, with the B57D3000 engine, uses an active tank with a capacity of 12.5 l, located in the vehicle underbody on the rear right behind the wheel, and an 8.5 l passive tank, located in the vehicle underbody on the rear right in front of the wheel. The filler connection for the urea/water mixture (AdBlue®) is located in the fuel filler flap (at the right rear) beside the fuel filler neck (diesel fuel).

# B57 Engine

## 10. SCR 3

### 10.1.2. System overview in detail

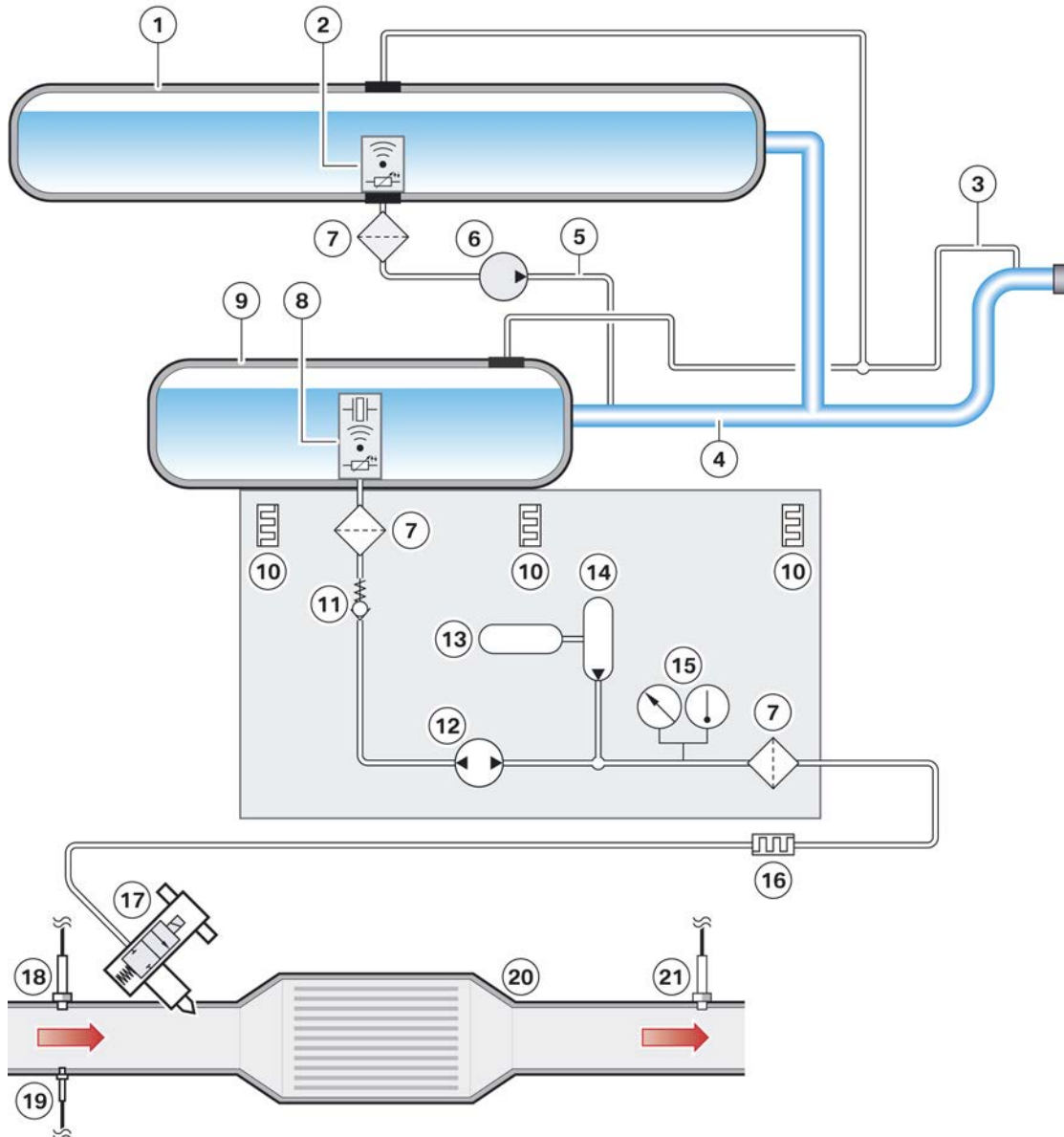

SCR 3 system overview

TD16-0572

Index	Explanation
1	Passive tank
2	Tank flange, passive tank with level sensor and temperature sensor
3	Tank ventilation line
4	Fluid filler neck breather pipe
5	Transfer line
6	Recirculating pump unit

# B57 Engine

## 10. SCR 3

<b>Index</b>	<b>Explanation</b>
7	Filter
8	Tank flange, active tank with hydraulics, filling level sensor, quality sensor, heating and temperature sensor
9	Active tank
10	Heating
11	Shutoff valve (open with the pump installed)
12	Pump
13	Ice pressure damper
14	Pressure accumulator
15	Pressure sensor/temperature sensor
16	Heating metering line
17	Metering valve
18	NO <sub>x</sub> sensor before the SCR catalytic converter
19	Exhaust-gas temperature sensor after diesel particulate filter
20	SCR catalytic converter
21	NO <sub>x</sub> sensor after SCR catalytic converter

# B57 Engine

## 10. SCR 3

### 10.1.3. System wiring diagram

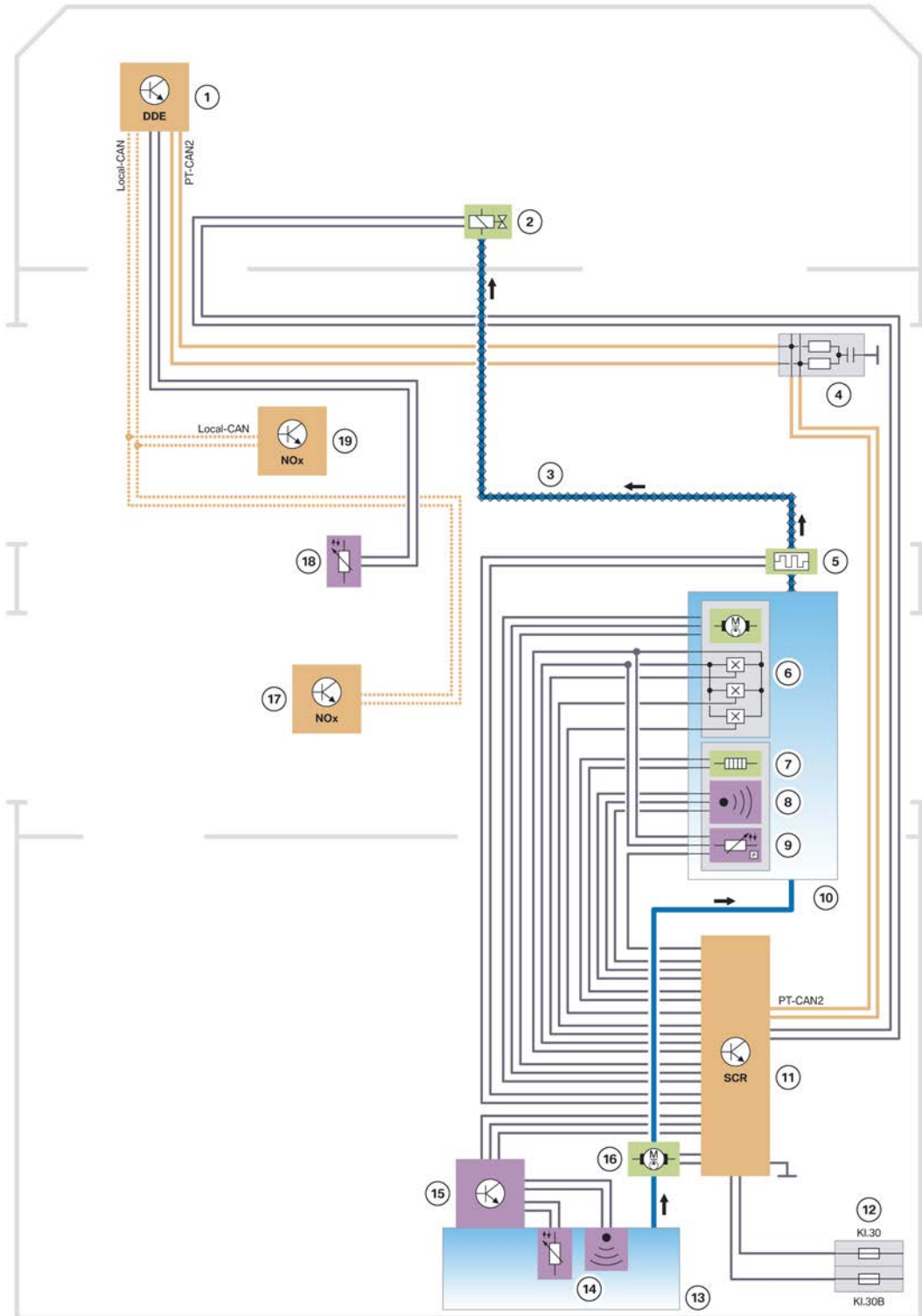

SCR 3 system wiring diagram (G30)

TD16-0573

# B57 Engine

## 10. SCR 3

<b>Index</b>	<b>Explanation</b>
1	Digital Diesel Electronics (DDE)
2	Metering module
3	Metering line
4	PT-CAN coupler
5	Heating metering line
6	Pump motor with hall effect sensor
7	Tank flange module heating
8	Filling level sensor and quality sensor
9	Temperature sensor and pressure sensor
10	Active tank flange module
11	SCR control unit
12	Fuses, supply of SCR control unit
13	Passive tank
14	Level sensor and temperature sensor, passive tank
15	Evaluation unit, passive tank
16	Recirculating pump unit
17	NO <sub>x</sub> sensor before the SCR catalytic converter
18	Exhaust-gas temperature sensor
19	NO <sub>x</sub> sensor after SCR catalytic converter

# B57 Engine

## 10. SCR 3

### 10.2. Functions

#### 10.2.1. SCR control

SCR control takes place in the SCR control unit and in the DDE (Digital Diesel Electronics).

The SCR control is divided into the SCR metering system control, which is implemented by the SCR control unit, and the metering strategy, which is defined by the DDE.

The SCR control unit assumes the following functions:

- System functions CAN communication and network management
- Control of the urea/water mixture (AdBlue®) pumps, metering line filling/metering line emptying and pressure build-up/pressure reduction
- Control of the urea/water mixture (AdBlue®) metering module, implementation of the metering volume set by the Digital Diesel Electronics (DDE)
- Control of the urea/water mixture (AdBlue®) heaters
- Evaluation of the level sensors and temperature sensors
- Evaluation of the quality sensor urea/water mixture (AdBlue®)
- Monitoring functions
- On-board diagnosis OBD monitoring
- Controlling the heating in the active tank and metering line
- Controlling the pump transfer function from the passive tank (if installed) to the active tank



# B57 Engine

## 10. SCR 3

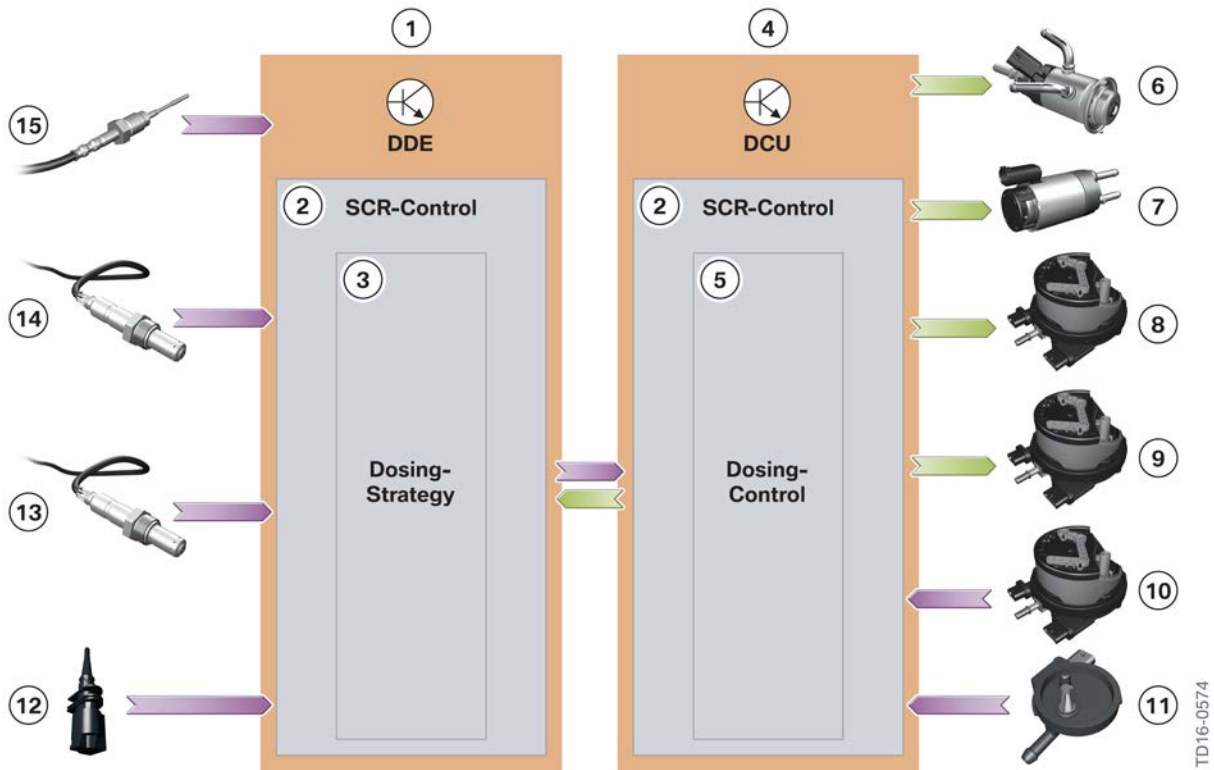

TD16-0574

SCR 3, SCR control

Index	Explanation
1	Digital Diesel Electronics (DDE)
2	SCR control
3	Metering strategy
4	SCR control unit
5	Dosing system control
6	SCR metering module with heating in the metering line
7	Recirculating pump unit
8	Pump in the active tank flange
9	Heaters in the active tank flange
10	Filling level sensor, quality sensor, pressure sensor and temperature sensor in the tank flange active tank
11	Level sensor and temperature sensor in tank flange, passive tank
12	Outside temperature sensor
13	NO <sub>x</sub> sensor before the SCR catalytic converter
14	NO <sub>x</sub> sensor after SCR catalytic converter
15	Exhaust-gas temperature sensor

# B57 Engine

## 10. SCR 3

The Digital Diesel Electronics (DDE) assumes the following functions:

- Evaluation of the nitrogen oxide sensor
- Evaluation of the exhaust-gas temperature sensor
- Calculation of the urea/water mixture (AdBlue®) amount and transmission to the SCR control unit via PT-CAN
- Control of the switch off scenario

### Metering strategy

The metering strategy in the Digital Diesel Electronics (DDE) is the part of the SCR control that calculates how much urea/water mixture (AdBlue®) is injected at which time.

The signal of the  $\text{NO}_x$  sensor before the SCR catalytic converter is used for the calculation of the quantity in normal operation. This calculates the amount of nitrogen oxide in the exhaust gas and transmits the value to the Digital Diesel Electronics (DDE).

However, the  $\text{NO}_x$  sensor must reach its operating temperature in order to begin measuring. Depending on the ambient temperature this can take up to 15 min. Until this point, a substitute value is calculated by the DDE for the determination of the nitrogen oxide quantity in the exhaust gas.

In order to monitor the system there is a second  $\text{NO}_x$  sensor located after the SCR catalytic converter. It measures whether there are still Nitrogen Oxide present in the exhaust gas at that point. If this is the case, then the fluid injection rate of the urea/water mixture (AdBlue®) is adapted accordingly. The  $\text{NO}_x$  sensor does not, however, just measure the Nitrogen Oxide, but also ammonia, but is unable to make a distinction between the two.

If too much urea/water mixture (AdBlue®) was injected, the Nitrogen Oxide are completely reduced. However, there is an increased risk of what is known as "ammonia slip" or leakage; in other words ammonia escapes from the SCR catalytic converter. The signal value increases as the  $\text{NO}_x$  sensor measures again. Therefore, the target is set to when the sensor signal reaches a minimum value (item 2 in the graph below).

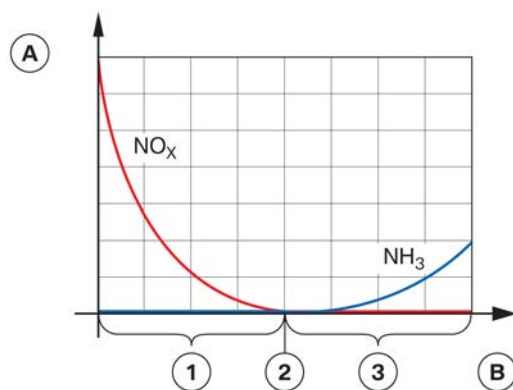

Nitrogen oxide and ammonia emissions diagram for the SCR system

TD11-0208

# B57 Engine

## 10. SCR 3

Index	Explanation
A	Calculated value of the NO <sub>x</sub> sensor
B	Injected quantity of urea/water mixture (AdBlue®)
1	Insufficient quantity of urea/water mixture (AdBlue®) injected
2	Correct quantity of urea/water mixture (AdBlue®) injected
3	Too large a quantity of urea/water mixture (AdBlue®) injected

**However, this is a long-term adaptation and not a short-term control as the SCR catalytic converter has a memory function for ammonia.**

### Metering system control

The metering system control in the SCR control is thus the implementing function. It implements the requirements set by the metering strategy. This includes both the metering and the injection of the urea/water mixture (AdBlue®) as well as the supply of the urea/water mixture (AdBlue®).

In the following, the tasks of the metering system control in normal operation are listed:

Metering of the urea/water mixture (AdBlue®):

- Implementation of the required target amount of urea/water mixture (AdBlue®)
- Return of the required urea/water mixture actual quantity (AdBlue®)

Supply of the urea/water mixture (AdBlue®):

- Provision of the metering ability (fill lines and pressure build-up) under certain ambient conditions (temperature)
- Empty lines at after-run
- Activation of the heating

### 10.2.2. Supply of the urea/water mixture (AdBlue®)

The Selective Catalytic Reduction (SCR) system requires a constant supply of urea/water mixture (AdBlue®). This medium must be stored in the vehicle and made available as quickly as is necessary under all ambient conditions. This means that the urea/water mixture (AdBlue®) should be always available at the metering valve under a required pressure.

### 10.2.3. Metering of the urea/water mixture (AdBlue®)

The metering strategy establishes what quantity of the urea/water mixture (AdBlue®) should be injected. The metering system control now ensures the implementation of this requirement. The metering activation is a part of the function from which the actual opening of the metering valve is determined.

Depending on the load level of the engine and speed of the vehicle, the metering valve injects with a frequency of 0.55 Hz to 20 Hz.

# B57 Engine

## 10. SCR 3

In order to inject the right amount the metering control calculates the following:

- Duty cycle for the actuator of the metering valve in order to determine the injection period
- Activation delay to compensate for metering valve inertia

The metering system control also calculates the actual metered amount and sends this back to the metering strategy.

The metering amount is also calculated over a longer period of time. This long term calculation is reset upon filling.

In order to fulfil these tasks various functions are necessary that are described in the following.

### Heating

As the urea/water mixture (AdBlue®) freezes at a temperature of -11 °C (12.2 °F) the system must be heated.

The heating has the following tasks:

- Monitoring of the temperatures in the active tank and its surrounding area
- Thawing of a sufficient amount of urea/water mixture (AdBlue®) and the components required for metering at system start up
- Prevention of freezing of the relevant components during operation
- Monitoring of the components of the heating system

The following components are heated:

- Active tank via flange module
- Metering line (from the active tank to the metering module)

The heating of the active tank is adjusted depending on the temperature in the active tank and the ambient temperature. The required control of the heating for the metering line and the heating for the tank flange module are based on the current values of the ambient temperature and the temperature of the urea/water mixture (AdBlue®).

The heater circuits are supplied with power by a semiconductor switch. The power semiconductor is designed as high side switch; it is controlled directly by the control unit. With help of a measuring shunt, the SCR control unit calculates the actual current, flowing over the heating elements. The SCR control unit can also perform a function check of the heater circuits and thus detect any faults which are stored in the fault memory.

A temperature model is used for the heating of the components in order to establish the metering readiness.

The following three basic parameters are set in the temperature model so that metering readiness can be reached.

# B57 Engine

## 10. SCR 3

The following values are defined by law and must be observed:

- At - 25 °C (-13 °F), metering readiness is reached after 45 minutes.
- At - 15 °C (5 °F), metering readiness is reached after 20 minutes.
- At - 9 °C (15.8 °F), metering readiness is reached after 3 minutes.

The following table shows the metering readiness in relation to the temperature:

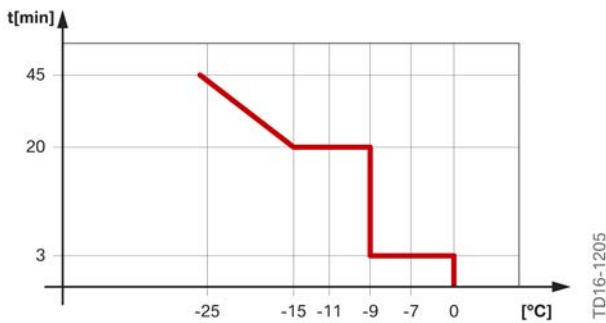

SCR 3, metering readiness temperature

Index	Explanation
t [min]	Time in minutes
°C	Temperature in degree Celsius

At a temperature below - 9 °C (15.8 °F) in the active tank, metering readiness is delayed, i.e. a defined time is waited until a pressure build-up attempt begins. This time is constant from - 9 °C (15.8 °F) to - 16.5 °C (2.3 °F) as the temperature up to which the urea/water mixture (AdBlue®) is frozen cannot be ascertained. At less than -16.5 °C (2.3 °F), the heating period until a pressure build-up attempt is extended.

Generally heating up the metering line is significantly faster which is why the temperature in the active tank is decisive for the period until a pressure build-up attempt has been undertaken. If there is significantly lower ambient temperature than the temperature in the active tank it can occur that the warm-up phase of the metering line becomes longer. Then the ambient temperature is used for the delay of the metering readiness.

### Recirculated pumping

As storing the urea/water mixture (AdBlue®) requires two tanks (depending on the series) a recirculated pumping is required.

The delivery of urea/water mixture (AdBlue®) from the passive to the active tank is described as recirculated pumping.

During transfer pumping, the transfer pump pumps the urea/water mixture (AdBlue®) from the passive tank into the filling pipe. Because the filling pipe in the active tank is located below the filling pipe of the passive tank, the urea/water mixture (AdBlue®) does not return to the passive tank, but flows into the active tank.

The following image illustrates the installation position of the components.

# B57 Engine

## 10. SCR 3

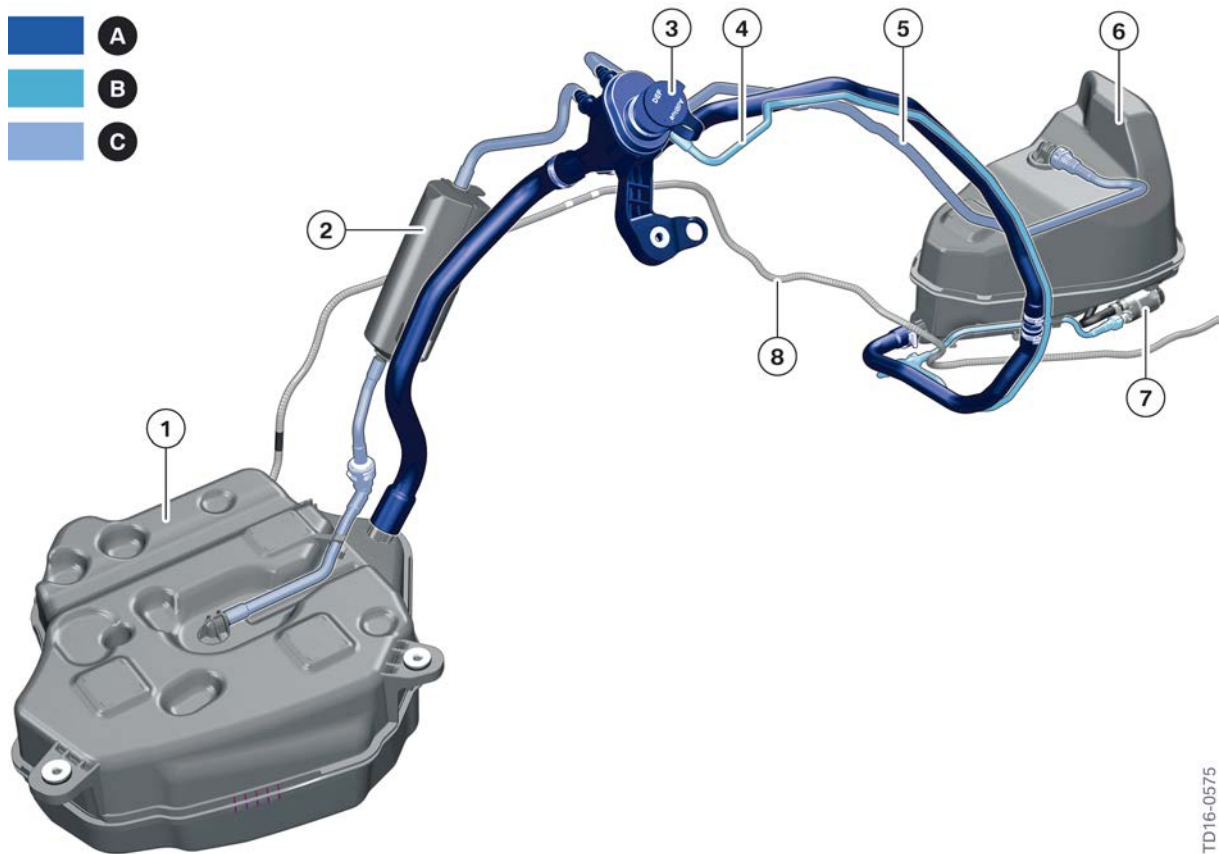

Pipes of SCR 3 tank system (G30)

TD16-0575

Index	Explanation
A	Fluid filler neck breather pipes
B	Transfer lines
C	Tank ventilation lines
1	Active tank
2	Bubble container
3	Filler cap with active tank and passive tank filling line
4	Transfer line
5	Tank ventilation line
6	Passive tank
7	Recirculating pump unit
8	Metering line

# B57 Engine

## 10. SCR 3

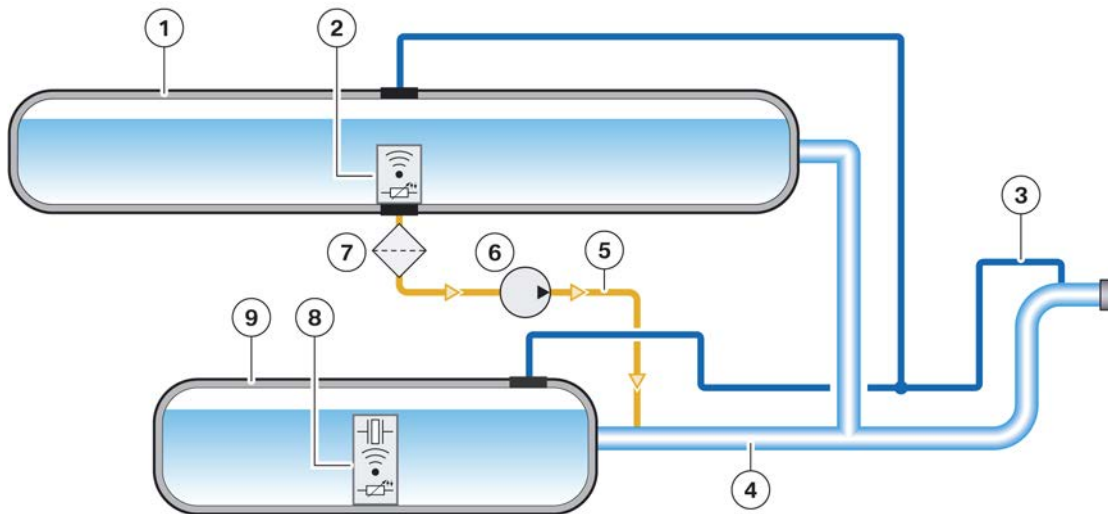

TD16-0576

SCR 3, transfer pumping

Index	Explanation
1	Passive tank
2	Temperature level sensor, passive tank
3	Tank ventilation line
4	Fluid filler neck breather pipe, active tank — passive tank
5	Transfer line
6	Recirculating pump unit
7	Filter
8	Temperature sensor, filling level sensor and quality sensor active tank
9	Active tank

The following preconditions must be met for recirculated pumping:

- There is urea/water mixture (AdBlue®) in the passive tank.
- The ambient temperature is above a minimum value of -7 °C (19.4 °F) for at least ten minutes in the case of a longer engine switch-off time.
- The ambient temperature is above a minimum value of 0 °C (32 °F) for at least ten minutes in the case of a shorter engine switch-off time.
- A free volume of 300 g (10 oz) is reached in the active tank.
- Active tank and passive tank contain a liquid urea/water mixture (AdBlue®) (tank temperature below - 5 °C (23 °F)).

Then enough time is spent pumping until the active tank is full again. If the "full" level is reached before this, then transfer pumping is stopped.

If there is a fault in the fluid level sensor then there is no pumping.

# B57 Engine

## 10. SCR 3

### Delivery

The urea/water mixture (AdBlue®) is delivered from the active tank to the metering module. This pump located in the tank flange module handles this task. The tank flange module requires the following components for this:

- Filter
- Pump
- Pressure accumulator
- Pressure sensor
- Temperature sensor
- Filter
- Metering line
- Heating, metering line, if required
- Metering valve

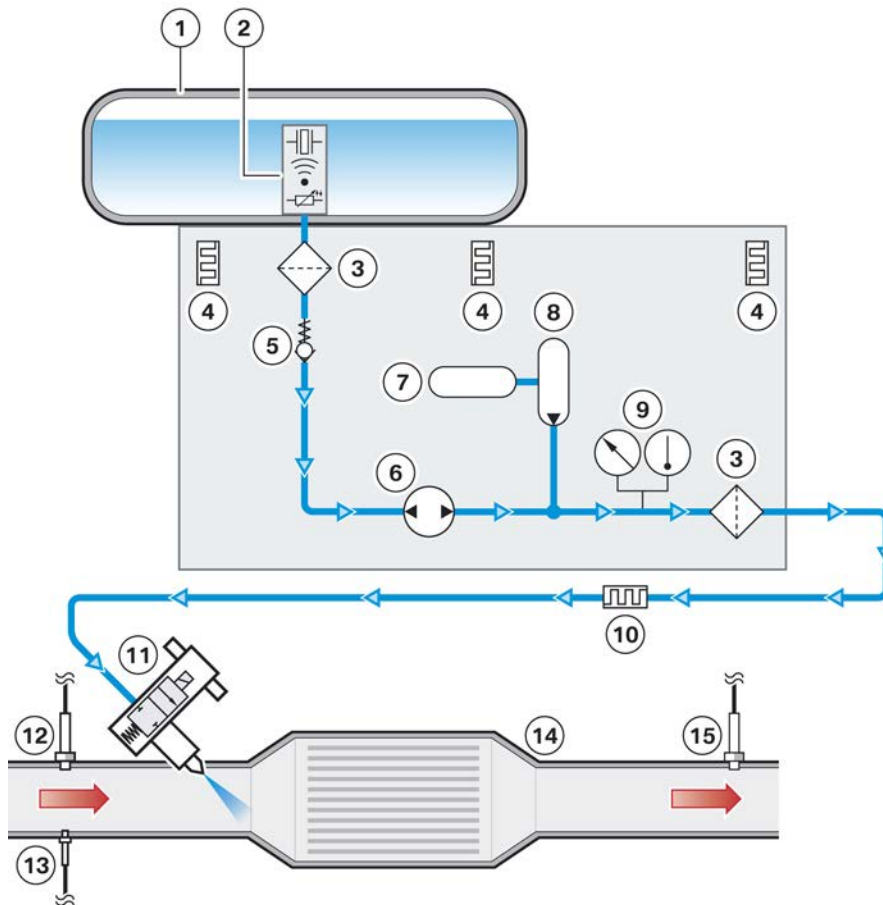

SCR 3, delivery

TD16-0577



# B57 Engine

## 10. SCR 3

Index	Explanation
1	Active tank
2	Temperature sensor, filling level sensor and quality sensor active tank
3	Filter
4	Heating
5	Shutoff valve (open with the pump installed)
6	Pump
7	Ice pressure damper
8	Pressure accumulator
9	Pressure sensor/temperature sensor
10	Heating metering line
11	Metering module
12	NO <sub>x</sub> sensor before the SCR catalytic converter
13	Exhaust-gas temperature sensor after diesel particulate filter
14	SCR catalytic converter
15	NO <sub>x</sub> sensor after SCR catalytic converter

The pump motor is activated by three-phase alternating current from the SCR control unit. Hall effect sensors monitor the direction of rotation and pump speed. The value for the speed specification is calculated by the SCR control unit based on the signal from the pressure sensor.

During the system start, the pump is activated at a fixed speed, and the line is thus filled up to the SCR metering module; pressure build-up then starts. Only then does the pressure regulation take place.

When filling the metering line a small amount of the urea/water mixture (AdBlue®) is injected into the exhaust system as the metering valve is open.

During pressure regulation, i.e. normal operation with metering, the pump is activated in such a way that a relative pressure of 5.5 bar is applied to the metering line. SCR 3 uses volumetric delivery, in other words, the volume of urea/water mixture (AdBlue®) delivered by the pre-supply pump is also actually injected at the metering valve.

The quantity is determined by the opening period and opening stroke of the metering valve. However, this is so low that no noticeable pressure drop occurs in the metering line under normal driving conditions.

To maintain the relative system pressure of 5.5 bar, the system is supported by a pressure accumulator in case of high urea/water mixture (AdBlue®) requirements. These high urea/water mixture (AdBlue®) requirements could occur, e.g. during an abrupt transition from idle to full throttle (dynamic start at traffic lights). To prevent a pressure drop in this case, the urea/water mixture (AdBlue®) request is supported by the pressure accumulator.



# B57 Engine

## 10. SCR 3

Index	Explanation
1	Active tank
2	Temperature sensor, filling level sensor and quality sensor active tank
3	Filter
4	Heating
5	Shutoff valve (open with the pump installed)
6	Pump
7	Ice pressure damper
8	Pressure accumulator
9	Pressure sensor/temperature sensor
10	Heating metering line
11	Metering module
12	NO <sub>x</sub> sensor before the SCR catalytic converter
13	Exhaust-gas temperature sensor after diesel particulate filter
14	SCR catalytic converter
15	NO <sub>x</sub> sensor after SCR catalytic converter

Even if the system has to be switched off due to a fault or, e.g if the minimum temperature in the active tank can no longer be maintained, it is drawn off.

It should by all means be avoided that a urea/water mixture (AdBlue®) remains in the metering line or metering module which could freeze.

When drawing off the metering valve is open.

### Frozen

If the ambient conditions (below - 11° C / 12.2 °F) cause the urea/water mixture (AdBlue®) to freeze, the components of the tank flange module are protected by ice pressure dampers.

# B57 Engine

## 10. SCR 3

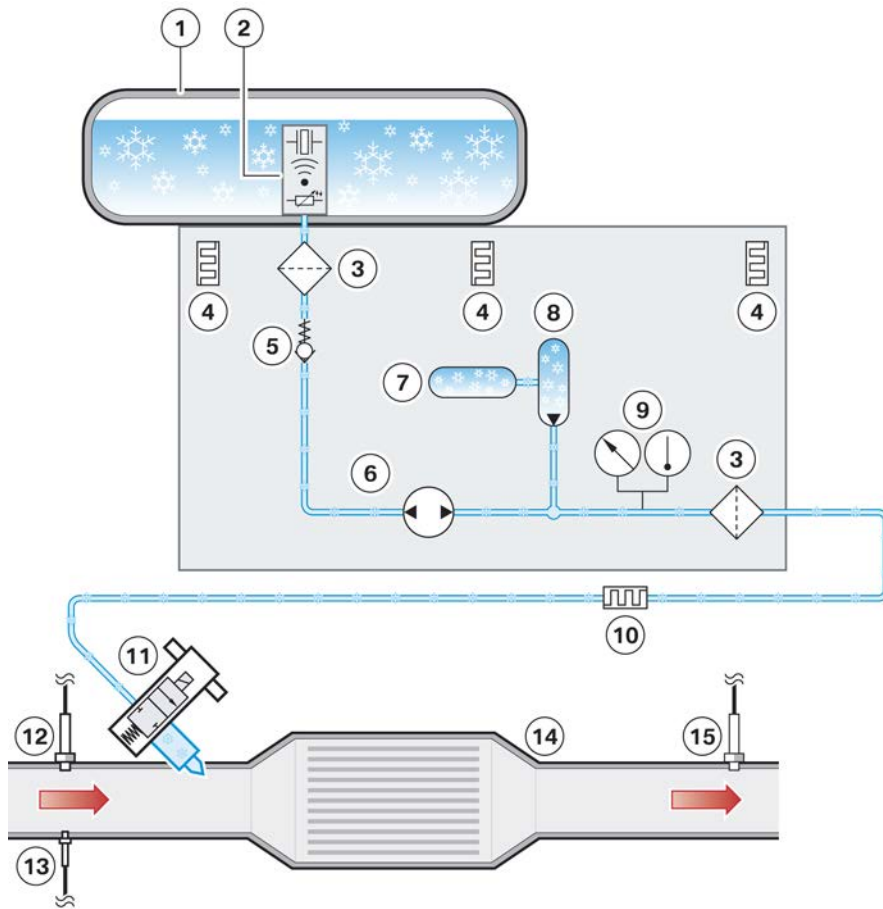

TD16-0579

SCR 3, frozen

Index	Explanation
1	Active tank
2	Temperature sensor, filling level sensor and quality sensor active tank
3	Filter
4	Heating
5	Shutoff valve (open with the pump installed)
6	Pump
7	Ice pressure damper
8	Pressure accumulator
9	Pressure sensor/temperature sensor
10	Heating metering line
11	Metering module

# B57 Engine

## 10. SCR 3

Index	Explanation
12	NO <sub>x</sub> sensor before the SCR catalytic converter
13	Exhaust-gas temperature sensor after diesel particulate filter
14	SCR catalytic converter
15	NO <sub>x</sub> sensor after SCR catalytic converter

The diaphragm in the ice pressure damper allow volume expansion in the internal lines of the tank flange module; the expansion is designed for the residual amount of urea/water mixture (AdBlue®) present in the SCR tank flange module. The resulting volume increase in the ice pressure damper protects the internal components of the tank flange due to ice formation. The ice pressure damper is located in the pressure accumulator.

### Filling level measurement passive tank and temperature measurement

The passive tank (if installed) contains a filling level sensor and a temperature sensor which are identical in design to the SCR 2. This is an ultrasonic sensor (direct piezo element) for the filling level; it can measure filling levels in a range of 15 mm to 400 mm. The temperature sensor is recessed into the tank flange and relies on the NTC (negative temperature coefficient) principle. The filling level sensor and temperature sensor signals are not sent directly to the SCR control unit, but to an evaluation unit in the tank flange, since the SCR control unit cannot process the results of the ultrasonic sensor and temperature sensor directly. The evaluation unit converts the ultrasonic value and measured value of the temperature sensors to a pulse-width modulated signal (PWM signal), which can be processed by the SCR control unit.

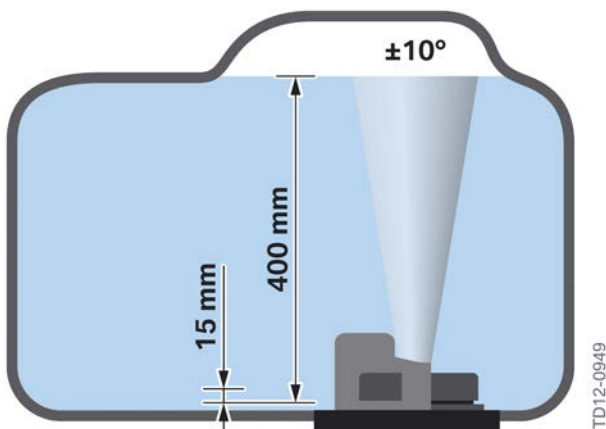

SCR 3, passive tank ultrasonic sensor filling level measurement range

# B57 Engine

## 10. SCR 3

### Active tank level measurement and temperature measurement

The sensor unit in the active tank contains a filling level sensor and the temperature sensor. An ultrasonic sensor (direct piezo elements) recessed in the sensor unit is used for filling level measurement. The filling level sensor relies on a piezo element based on the principle of ultrasonic sound operating time measurement; it records filling levels in a range of 25 mm to 400 mm. Both the direct and inverse piezo effect are used for this. In other words, the piezo element operates as a sensor and a receiver. The piezo element emits an ultrasonic pulse, which is reflected by the urea/water mixture (AdBlue®). The required operating time is a measure of the stroke travelled. The temperature sensor is also recessed into the tank flange and relies on the NTC (negative temperature coefficient) principle. The filling level sensor and temperature sensor signals are not sent directly to the SCR control unit, but to a sensor unit, since the SCR control unit cannot process the results of the piezo elements and temperature sensors directly. The sensor unit converts the piezo element values and the measured values from the temperature sensors into a SENT protocol, which the SCR control unit can process.

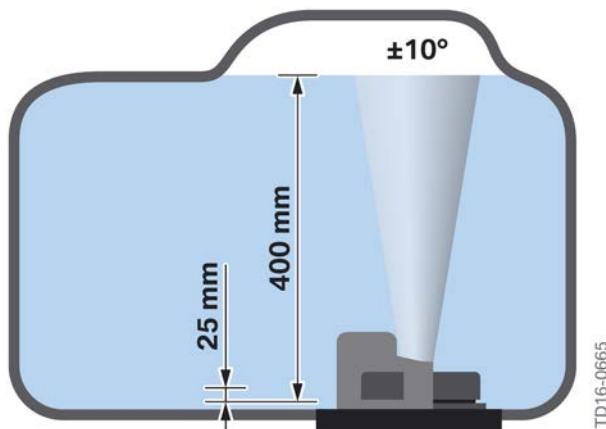

SCR 3, active tank ultrasonic sensor filling level measurement range

The sensors are active in the RESIDING-PAD-DRIVING states (Awake-Testing-Ready).

### Urea/water mixture (AdBlue®) Quality monitoring/filling level measurement active tank (combined piezo element)

As well as the direct filling level measurement, an additional filling level measurement combined with quality monitoring is used for the SCR 3. The combined quality monitoring/filling level measurement is implemented using a combined piezo element.

# B57 Engine

## 10. SCR 3

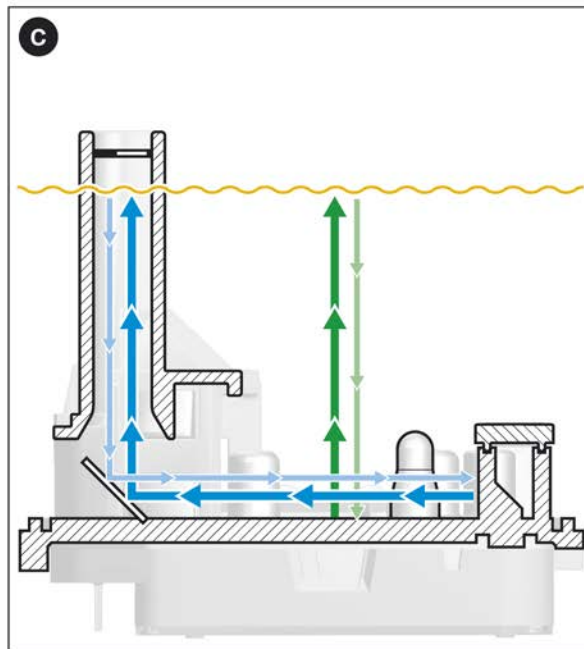
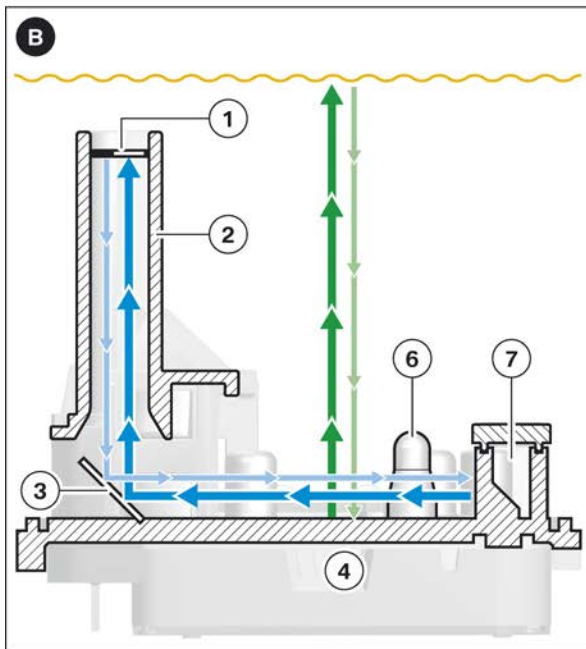
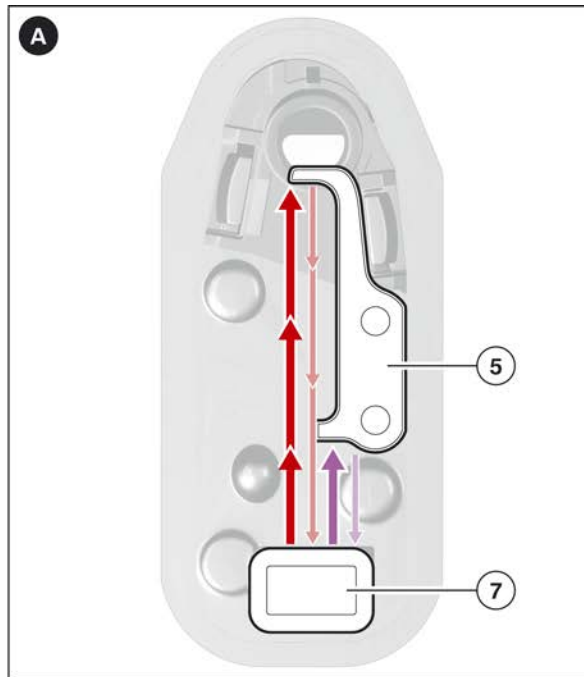
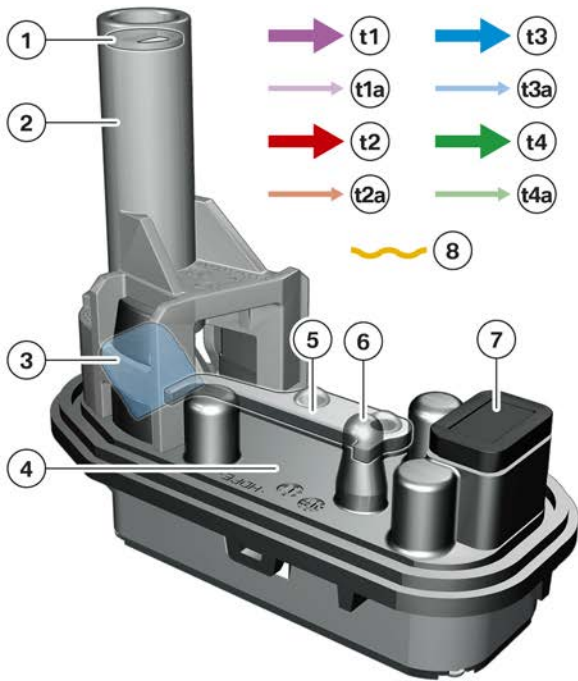

SCR 3, direct piezo element/combined piezo element

TD16-0666

# B57 Engine

## 10. SCR 3

Index	Explanation
A	Urea/water mixture (AdBlue®) quality sensor/sound propagation time reference measurement
B	Urea/water mixture (AdBlue®) filling level measurement, filling level high
C	Urea/water mixture (AdBlue®) filling level measurement, filling level low/ plausibility measurement
t1	Urea/water mixture (AdBlue®) quality sensor/sound transmitting channel 1
t1a	Urea/water mixture (AdBlue®) quality sensor/sound receiving channel 1
t2	Urea/water mixture (AdBlue®) quality sensor/sound transmitting channel 2
t2a	Urea/water mixture (AdBlue®) quality sensor/sound receiving channel 2
t3	Filling level measurement/sound transmitting channel 1 (17 - 58/59 mm)
t3a	Filling level measurement/sound receiving channel 1 (17 - 58/59 mm)
t4	Filling level measurement/sound transmitting channel 1 (25 - 400 mm)
t4a	Filling level measurement/sound receiving channel 1 (25 - 400 mm)
1	Reflector
2	Measuring tube/filling level
3	Passive reflector for determining the filling level
4	Direct piezo element
5	Reflector plate for urea/water mixture (AdBlue®) quality
6	Temperature sensor
7	Combined piezo element
8	Urea/water mixture (AdBlue®) filling level

During the filling level measurement using the combined piezo element, it is possible to monitor the filling levels in a range of 17 mm to 58/59 mm.

For a high urea/water mixture (AdBlue®) filling level as shown in Graphic B, the filling level measurement is conducted using the direct piezo element. If the urea/water mixture (AdBlue®) filling level is below the level of the measuring tube as shown in Graphic C, the measured values of the combined piezo element are used in addition to the direct piezo element measured values. This allows the plausibility of the two sensors to be monitored and also ensures a precise measured value when the urea/water mixture (AdBlue®) capacity is low.

### Urea/water mixture (AdBlue®) quality monitoring

The sound propagation time for the urea/water mixture (AdBlue®) quality monitoring is determined from two measurements; as shown in Graphic A. The measured sound propagation from transmitting the ultrasound signal t2 to receiving the ultrasound signal t2a is used as a measurement. The second measurement is based on the sound propagation times for the values t1 and t1a. The measured values are subtracted in order to determine the urea/water mixture (AdBlue®) quality downstream. **(t2+t2a)-(t1+t1a)**. The value obtained this way is the reference value for the urea/water mixture (AdBlue®) quality.



# B57 Engine

## 10. SCR 3

### Speed of sound

The speed of sound in a material depends on the material's chemical nature and thus the material constant. This means that the sound's propagation speed assumes a different value in each chemical compound. That means: For a fluid composed of two components, the system's sound velocity changes characteristically with the composition so that the respective composition can be determined using a sound velocity measurement when the concentration dependence is known (calibration measurement).

The sound velocity is strongly dependent on the temperature. A calibration measurement is therefore only valid for a certain temperature. If the intention is to take measurement at other temperatures, the calibration curve must be re-measured at this temperature.

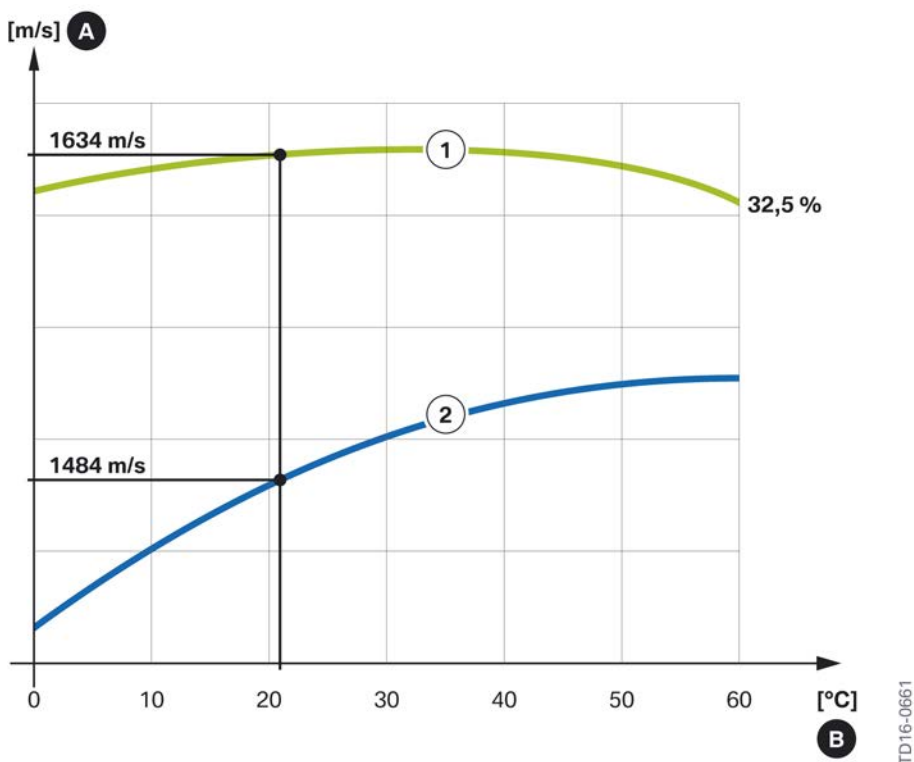

SCR 3, urea/water mixture (AdBlue®) concentration

Index	Explanation
A	Speed of sound
B	Temperature
1	Urea/water mixture (AdBlue®)
2	Water

The reference values for sound velocities for the respective temperatures of the urea/water mixture (AdBlue®) are saved in the SCR control unit. This allows the control unit to compare the actual values with the nominal values and display any deviation in the urea/water mixture (AdBlue®) quality using the malfunction indicator lamp.

# B57 Engine

## 10. SCR 3

The ultrasound sensors are connected to the electronic sensor unit via a conductor path. In the sensor unit, the ultrasound values are converted into a SENT protocol which can then be processed by the SCR control unit.

The combined urea/water mixture (AdBlue®) quality sensor/filling level sensor is active in the RESIDING-PAD-DRIVING states.



---

**To avoid overfilling the urea/water mixture (AdBlue®) refill using the KRUSE bottle/dispenser or the service filling hose to ensure that a defined air gap remains in the tank. This air gap is required so that the filling level sensors based on the runtime measurement can deliver a measuring result. If there is no air gap between the upper filling level and the tank housing, the sound waves will not be correctly reflected and this will lead to the filling level sensors malfunctioning.**

---

### Pressure monitoring

A combined pressure/temperature sensor with a measuring range of – 1 bar to 13 bar is used to monitor the system pressure of the SCR 3. The measured values of the pressure sensor are transmitted to an electronic evaluation unit in the electronic sensor unit. In the sensor unit, the pressure values are converted into a SENT protocol which can then be processed by the SCR control unit.

The pressure sensor is active in the RESIDING-PAD-DRIVING states.

### SENT protocol

#### Single Edge Nibble Transmission

Single Edge Nibble Transmission is a simple digital interface standardised in the automotive industry and used for communication between sensors and control units.

It is a unidirectional, asynchronous voltage interface that requires only three lines. This is the usual 5 V / 12 V supply voltage, the signal voltage and the ground connection. The SENT protocol is characterized by its simplicity and resistance to fault signals. Another advantage is that the data is available in digital format in the sensor after the A/D conversion, meaning it can be processed further directly by the control unit.

#### 10.2.4. Warning and switch off scenario

The SCR system is relevant for the exhaust-emission regulations. It thus fulfils an important emission requirement. If the system fails, the approval is void and the vehicle can no longer be operated. A very plausible case which leads to a system failure is that the supply of the urea/water mixture (AdBlue®) runs out.

Without urea/water mixture (AdBlue®) a further operation of the vehicle is not allowed, therefore the engine can no longer be started.

**The control of the switch off scenario is subject to the Digital Diesel Electronics (DDE).**

# B57 Engine

## 10. SCR 3

So that it does not come as a surprise to the driver, there is a warning and switch off scenario that begins long enough before the disabling of the vehicle so that the customers can comfortably either refill the urea/water mixture (AdBlue®) themselves or have it refilled by a BMW service department. According to legal regulations in the US the first warning must have a range of 1000 mls based on a linear counter.

### Warning scenario

#### Warning level 1

At the start of the inducement (engine shut off scenario) a residual amount of DEF (about 3 liters depending on model) should in any case be enough for a range of 1000 mls. The “linear counter” is started from this point irrespective of the actual DEF consumption. The driver receives a priority 1 Check Control message (white), with a check control message showing the remaining range.

A range of **999 mls** is actually displayed to provide a safety reserve margin.

Check Control display: **“Refill Exhaust Fluid Reserve/AdBlue, range: 999 mls”**



SCR 3, Check Control message in the instrument cluster at warning level 1

At the same time, an instruction is also output via the Central Information Display (CID):

**“Exhaust Fluid /AdBlue Reserve. Exhaust Fluid /AdBlue must be refilled. Have vehicle checked by your BMW Service Department.”**

From this point onwards, the available range is counted downwards linearly, irrespective of actual urea/water mixture (AdBlue®) consumption.

#### Warning level 2

If the fluid level sensor has dropped below “empty” then the driver receives a priority 2 Check Control message (yellow). “Refill DEF” and the remaining range is displayed in miles. Although there is still a DEF reserve in the active tank (which would normally allow a range greater than 200 miles) a range of 199 mls is actually displayed to provide a safety reserve margin.

Check Control display: **“Refill Exhaust Fluid Reserve/AdBlue®, range: 199 mls”**



SCR 3, Check Control message in the instrument cluster at warning level 2

At the same time, an instruction is also output via the Central Information Display (CID):

**“Refill Exhaust Fluid /AdBlue®”**

**“Note range! Exhaust Fluid /AdBlue® must be refilled, immediately, otherwise it will not be possible to restart the engine. Drive to the nearest BMW Service.”**

# B57 Engine

## 10. SCR 3

From this point onwards, the available range is counted downwards linearly, irrespective of actual urea/water mixture (AdBlue®) consumption.

### Warning level 3

If the range falls to 0 ml three lines are displayed instead of the range – next to the fuel gauge.



SCR 3, Check Control message in the instrument cluster range = 0 mls

Check Control display: **“Refill Exhaust Fluid/AdBlue®, range: — — —”**

At the same time, an instruction is also output via the Central Information Display (CID):

**“Refill Exhaust Fluid /AdBlue®”**

**“Engine start without Exhaust Fluid /AdBlue® is no longer possible. Diesel Exhaust Fluid / AdBlue® must be refilled. Please drive to the nearest BMW Service Department”**

### Switch off scenario

When the range of 0 mls has been met the next engine start is prevented, **but only if the engine was switched off for more than three minutes**. This ensures being able to escape any dangerous situations.

The normally remaining 0.8 l are a safety reserve for the following scenarios:

- The vehicle is filled up with fuel and is started with a very low urea/water mixture (AdBlue®) range (e.g. 1 km). The urea/water mixture (AdBlue®) range reaches 0 km/mls but the vehicle can still be driven until the next engine shutdown. Here it is ensured that the vehicle is still operated with a functioning SCR system, even in this case.



---

**For vehicles with PRD (Parking/Residing/Driving), the SCR control unit with the SCR 3 is also active in the Residing state, but is switch off after around ten seconds by the sub-power supply operation. The SCR control unit must be activated in the PAD state in order to ensure secure refilling detection. In addition, press the START-STOP button three times in quick succession. Observe the notes in the motor vehicle's operating instructions.**

---

### Incorrect filling

If an incorrect medium is filled, this will be displayed by the quality sensor's quality monitoring. However, this also manifests itself a few hundred miles later as the nitrogen oxide (NO<sub>x</sub>) levels in the exhaust gas increase, despite sufficient injecting of the urea/water mixture (AdBlue®). If certain limit values are exceeded, the system identifies a wrong medium. From this point this is displayed by a Check Control symbol (display of range or a reduction of range is not displayed).

# B57 Engine

## 10. SCR 3



SCR 3, Check Control message in the instrument cluster in the event of wrong medium detected

Check Control symbol: **“Exhaust Fluid/AdBlue® wrong medium”**

At the same time, an instruction is also output via the Central Information Display (CID):

**Exhaust Fluid/AdBlue® wrong fluid”**

**“Have the vehicle checked by your BMW Service Authorized Workshop.”**

### System fault

A system fault is displayed and the range reduced if faults occur that prevent the urea/water mixture (AdBlue®) being metered or if there is a failure or fault with the communication between the Digital Diesel Electronics (DDE) and the SCR control unit.



SCR 3, Check Control message in the instrument cluster in the event of system fault

Check Control symbol: **“Exhaust Fluid/AdBlue® system fault”**

At the same time, an instruction is also output via the Central Information Display (CID):

**Exhaust Fluid/AdBlue® system fault**

**"Have system checked by your BMW Service Department."**



---

For the workshop to be able to start the engine for troubleshooting in the case of an **“AdBlue® system fault”**, or to support self-diagnosis by the SCR system, the ISTA diagnosis system includes the service function “Reset: SCR switch-off scenario”. The reset function allows additional engine starts as well as an additional range of 50 km for self-diagnosis with the SCR 3 system. Further information in the chapter: "Service instructions for troubleshooting".

---

### 10.2.5. On-board diagnosis functions

The Digital Diesel Electronics (DDE) additionally has the task of monitoring all exhaust-relevant systems for their problem-free function. This task is described as an On-Board Diagnosis (OBD). If a fault is registered by the On-Board Diagnosis then the emissions warning light is activated.

In the following the most important SCR specific results are explained that lead to the lighting up of the emissions warning light.

# B57 Engine

## 10. SCR 3

### SCR catalytic converter

The effectiveness of the SCR catalytic converter is monitored by the two nitrogen oxide sensors.

The nitrogen oxide mass is measured before and after the SCR catalytic converter and a sum is formed over a certain period. The actual reduction is compared to a calculated value which is stored in the Digital Diesel Electronics (DDE).

For this the following preconditions must be met:

- NO<sub>x</sub> sensors plausible
- Metering active
- Ambient temperature in the defined area
- Ambient pressure in the defined area
- Diesel particulate filter regeneration not active
- SCR catalytic converter temperature in the defined area (is calculated using exhaust-gas temperature sensor before the SCR catalytic converter amongst others)
- Exhaust flow in the defined area

Monitoring includes four measuring cycles. If the actual value is lower than the one calculated a reversible fault is created. If the fault is determined in three successive driving cycles, then an irreversible fault is stored and the malfunction indicator lamp is activated.

In order to guarantee the SCR catalytic converter over a long period there is a metering-quantity adaptation in which the metered amount is adjusted to the urea/water mixture (AdBlue®). In order to undertake the adaptation the signal of the NO<sub>x</sub> sensor after the SCR catalytic converter is continuously compared with a calculated value. If deviations occur here then the metering amount is adjusted in the short-term. The systematics of the adaptations is evaluated and a correction factor is applied to the metering amount.

If the correction factor exceeds a certain threshold a reversible fault is created. If the fault is determined in three driving cycles following one another then an irreversible fault is stored and the emissions warning light is activated.

### Supply of urea/water mixture (AdBlue®)

For a problem-free function of the SCR catalytic converter the supply of urea/water mixture (AdBlue®) is necessary.

After the SCR catalytic converter reaches a certain temperature (calculated by the exhaust-gas temperature sensor in front of the SCR catalytic converter, amongst other things) the metering control tries a pressure build-up in the metering line. To allow this to happen, the metering module must also be closed and the pump must be activated for a certain amount of time.

If the pressure threshold cannot be reached within a certain amount of time then the metering module is opened in order to bleed the metering line. Subsequently a renewed pressure build-up is attempted.

If a set number of pressure build-up attempts take place unsuccessfully then a reversible fault is created. If the fault is determined in three successive driving cycles, then an irreversible fault is stored and the malfunction indicator lamp is activated.

# B57 Engine

## 10. SCR 3

This monitoring only runs once per driving cycle before the metering begins. If this monitoring is "passed" then the continuous pressure monitoring begins.

For the Selective Catalytic Reduction (SCR) a constant pressure of the urea/water mixture (AdBlue®) is necessary (5,5 bar). The actual pressure and the resulting pressure module are determined and monitored by the SCR control unit using the pressure sensor. The following values are checked:

- High pressure
- Vacuum
- Implausible pressure readings

If these limits are exceeded for a certain amount of time a reversible fault is created. If the fault is determined in three driving cycles following one another then an irreversible fault is stored and the emissions warning light is activated, the pressure in the SCR system is reduced fully and the SCR system shut down.

This monitoring takes place in active metering.

### **Level measurement of active tank**

Two filling level sensors with piezo elements are used for the active tank. The plausibility of the sensors takes place in the sensor unit in which it is checked if the signals are logical.

In this case the sensor unit sends a plausibility fault via the SCR control unit to the Digital Diesel Electronics (DDE). A reversible fault is created. If the fault is determined in three successive driving cycles, then an irreversible fault is stored and the malfunction indicator lamp is activated.

This monitoring only takes place if the temperature in the active tank is above a certain value.

If the line between the sensor unit and at least one filling level sensor contact is interrupted, the fault is reported to the Digital Diesel Electronics (DDE). A reversible fault is created. If the fault is determined in three successive driving cycles, then an irreversible fault is stored and the malfunction indicator lamp is activated.

### **Suitable urea/water mixture (AdBlue®)**

The SCR system is monitored with a wrong medium in terms of refilling. This monitoring begins when refilling is identified. The refilling identification is described in the SCR system extract.

Both monitoring of the urea/water mixture (AdBlue®) medium quality and the effectiveness of the SCR catalytic converter are referenced in order to detect an incorrect medium. If the fault is determined in the following driving cycle then an irreversible fault is stored and the emissions warning light is activated.

### **NO<sub>x</sub> sensors**

For the function and therefore also the monitoring of the NO<sub>x</sub> sensor a so-called dew point must be reached. This ensures that no more water is in the exhaust that could damage the NO<sub>x</sub> sensors.

If a fault is identified by the following monitoring of the NO<sub>x</sub> sensor then: A reversible fault is created. If the fault is determined in three successive driving cycles, then an irreversible fault is stored and the malfunction indicator lamp is activated.

# B57 Engine

## 10. SCR 3

The following faults are identified:

- Identification signal or correction factor wrong.
- Interrupted line or short circuit between measuring probe and control unit of the NO<sub>x</sub> sensor.
- Measured value outside of the defined area for a certain time.
- Operating temperature is not reached after a defined heating period.
- In coasting (overrun) mode (no nitrogen oxide expected) too great a distance from the measured value to zero is identified.
- In the transfer from the load in coasting (overrun) mode the signal of the NO<sub>x</sub> sensor does not fall from 80% to 50% quickly enough (only NO<sub>x</sub> sensor before the SCR catalytic converter).
- If, despite a spike in the signal of the NO<sub>x</sub> sensor before the SCR catalytic converter there is not at least one defined change in the signal of the NO<sub>x</sub> sensor after the SCR catalytic converter, then this counts as implausible.

### Display and driver information

The SCR control unit delivers the combined data from the level sensor in the active tank and passive tank, if installed, to the Digital Diesel Electronics (DDE), which makes the data accessible to other bus users via the FlexRay and central gateway module (ZGM) or the Body Domain Controller (BDC).

## 10.3. System components

### 10.3.1. Passive tank

The name passive tank means that it is not heated.

The following components belong to the passive tank:

- Tank flange with level sensor and temperature sensor
- Filling port
- Service vent line, fluid filler neck breather

Depending on the series, it is possible that the passive tank is insulated. The insulation comprises foam material and prevents quick freezing at low temperatures. As its installation location may also be near the exhaust system depending on the vehicle, it would also lead to a high introduction of heat to the urea/water mixture (AdBlue®).

If there are very low temperatures over a long period of time there is a possibility that the urea/water mixture (AdBlue®) might freeze completely in the passive tank. No re-pumping can then take place. In this case the active tank must be refilled more often.

The passive tank is filled via the active tank therefore it cannot be filled separately.



# B57 Engine

## 10. SCR 3

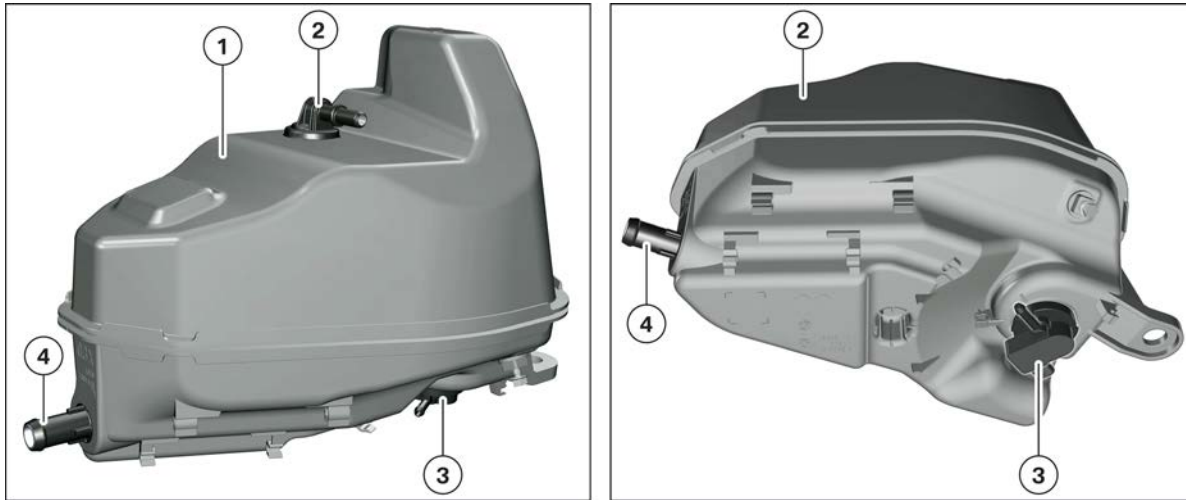

SCR 3, passive tank two-tank system

Index	Explanation
1	Passive tank
2	Service vent line and fluid filler neck breather
3	Tank flange with level sensor and temperature sensor
4	Filling port

### Fuel level sensor

A level sensor is located in the tank flange of the passive tank.

The sensor works with a piezo element.

On extreme sloping positions or if the tank is frozen, the signal is at 15 mm. This corresponds to the signal of an empty tank. A level sensor is located, as described, in the active tank and in the passive tank.

# B57 Engine

## 10. SCR 3

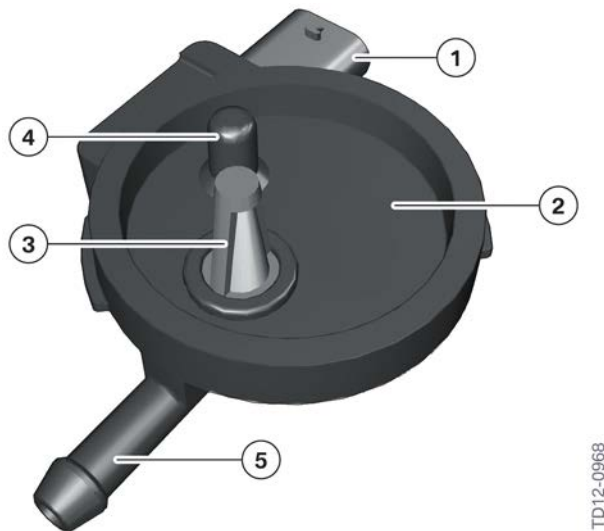

TD12-0968

SCR 3, tank flange in the passive tank

Index	Explanation
1	Electrical connection
2	Ultrasonic sensor
3	Strainer filling level
4	Flange with integrated temperature sensor
5	Transfer line connection

The tank flange of the passive tank cannot be replaced separately in service as it is welded to the passive tank.

### Temperature sensor

The temperature sensor is integrated in the tank flange and cannot be replaced separately. The temperature sensor integrated in the tank flange is installed in the active tank and the passive tank.

### Ventilation

The passive tank has a service vent line and a fluid filler neck breather.

The service vent line and fluid filler neck breather lead to the filling pipe for the urea/water mixture (AdBlue®) at the fluid filler cap.

# B57 Engine

## 10. SCR 3

### 10.3.2. Recirculating pump unit

The recirculating pump unit assumes the delivery of the urea/water mixture (AdBlue®) from the passive tank to the active tank. The recirculating pump unit is only present if a two-tank system, i.e. passive tank and active tank, is installed.

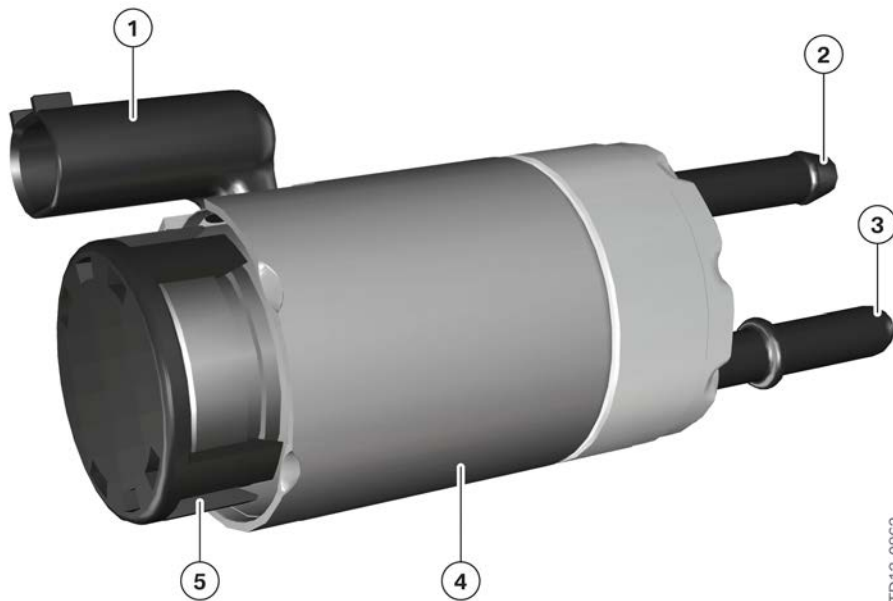

SCR 3, transfer pump

Index	Explanation
1	Electrical connection
2	Intake side from recirculating line passive tank
3	Pressure side to recirculating line fluid filler neck breather pipe active tank
4	Pump body
5	Pump motor

The recirculating pump unit is a membrane pump. It functions similarly to a piston pump, only that the pump element is separated from the medium via a diaphragm. This means there are no problems concerning corrosion.

# B57 Engine

## 10. SCR 3

### 10.3.3. Active tank

The active tank is so-called because it is heated.

The following components belong to the active tank:

- Service vent line, fluid filler neck breather
- Tank flange module

Depending on the series, it is possible that the active tank is insulated. The insulation comprises foam material and prevents quick freezing at low temperatures. As its installation location may also be near the exhaust system (depending on the vehicle) which would result in unintentional heating of the urea/water mixture (AdBlue®).



**Due to the possibility of incorrect refilling the Urea/water mixture (AdBlue®) filler necks are clearly marked as such. However, there is a danger of incorrect refilling by third parties. Incorrectly refilled urea/water mixture (AdBlue®) systems (in particular with materials containing mineral oil) may destroy the gaskets and seals in the SCR system.**

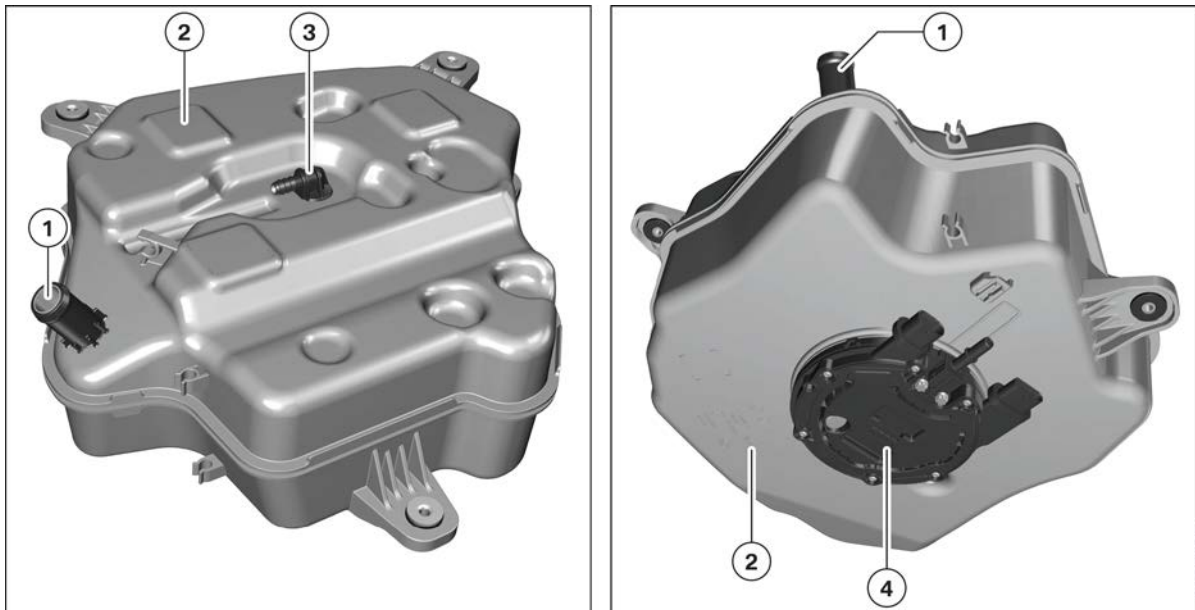

SCR 3, active tank

Index	Explanation
1	Filling port
2	Active tank
3	Service vent line and fluid filler neck breather
4	Tank flange module

# B57 Engine

## 10. SCR 3

### 10.3.4. Tank flange module

The tank flange module is located in the active tank and incorporates the heating element, a filter, temperature sensor, the combined urea/water mixture (AdBlue®) quality sensor/filling level sensor and a filling level sensor. The tank flange module also houses the pump as well as a pressure sensor and a pressure accumulator. The tank flange module cannot be replaced separately in service as it is part of the active tank.

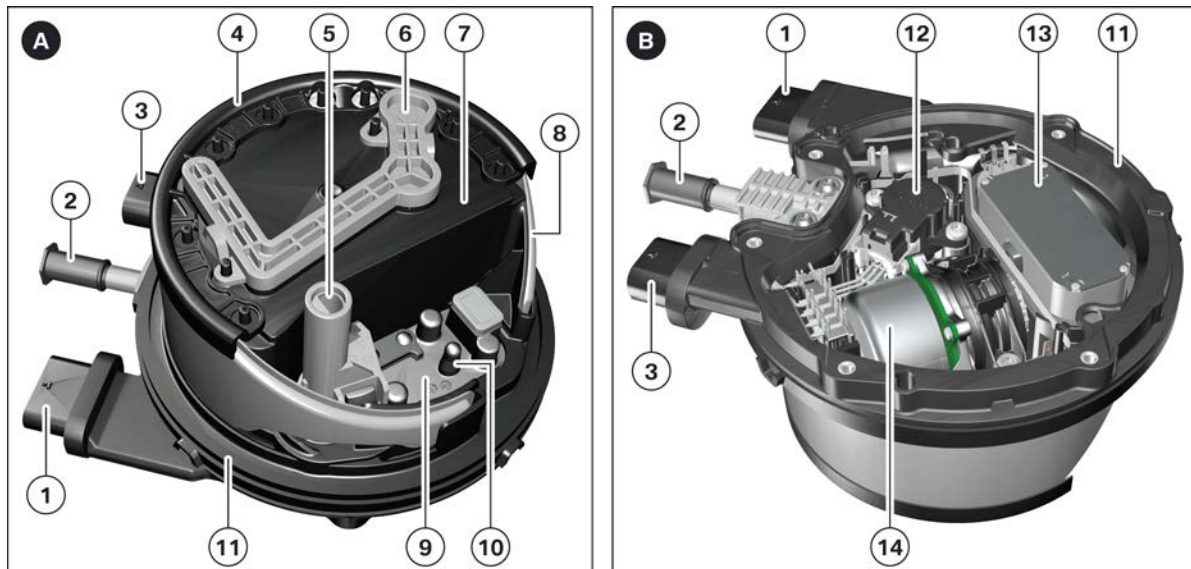

SCR 3, tank flange module

Index	Explanation
A	Top view of the tank module
B	Bottom view with service cover removed
1	Electrical connection for the heater and SENT protocols
2	Metering line connection
3	Electrical connection for voltage supply, the pump, hall effect sensors and filter
4	Bulkhead
5	Riser pipe filling level sensor (combined piezo element)
6	Pressure line
7	Tank flange module housing
8	Filter element
9	Filling level sensor (direct piezo element)
10	Temperature sensor

# B57 Engine

## 10. SCR 3

Index	Explanation
11	Carrier plate
12	Pressure sensor/temperature sensor
13	Sensor unit (temperature filling level urea/water mixture (AdBlue®) quality sensor)
14	Pump

### Bulkhead

The tank flange module has a bulkhead in order to ensure there is enough urea/water mixture (AdBlue®) even when the vehicle is in extremely inclined position with a small amount remaining in the active tank. Thanks to this bulkhead and the design of the filter element around the tank flange module, it is ensured that there is enough urea/water mixture (AdBlue®) available up to a vehicle inclination of 45°.

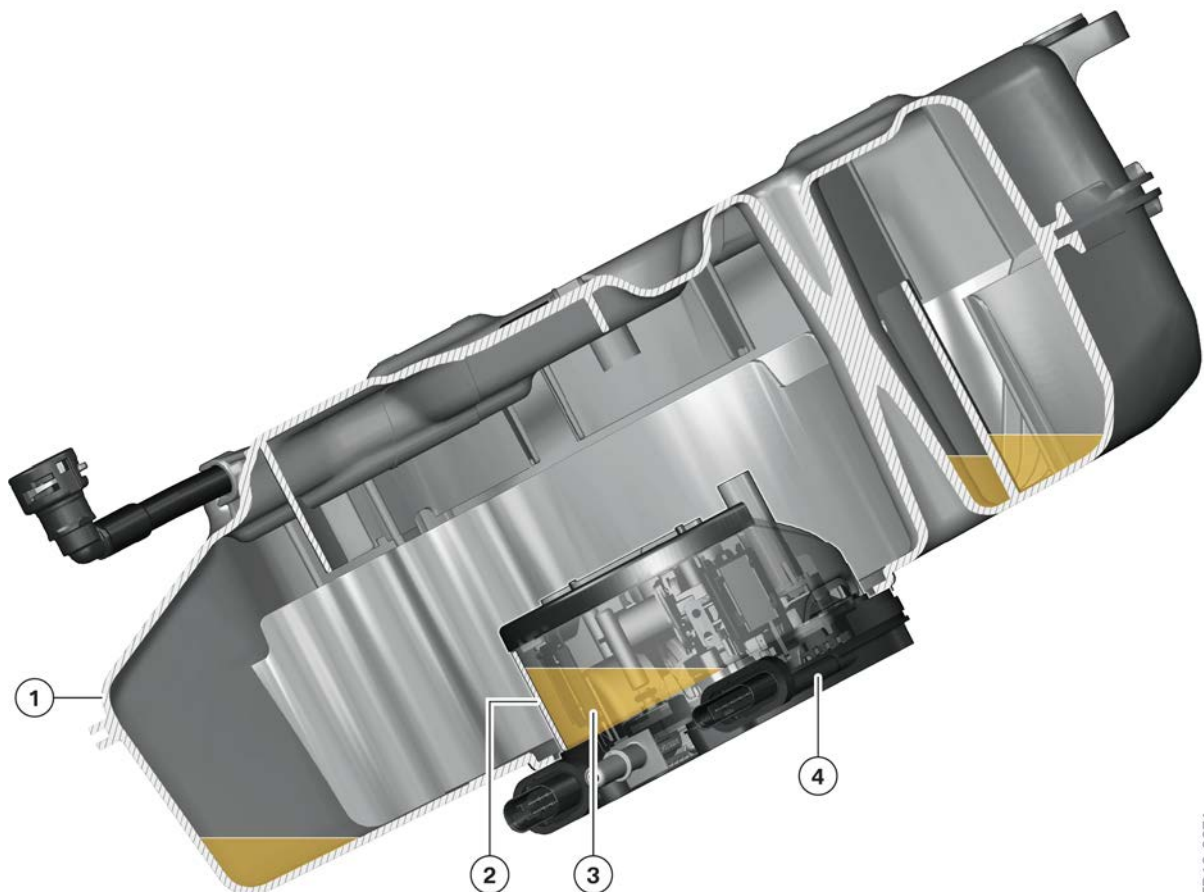

SCR 3, tank flange module/bulkhead

TD16-0671

# B57 Engine

## 10. SCR 3

Index	Explanation
1	Active tank
2	Bulkhead with filter
3	Urea/water mixture (AdBlue®) residual amount
4	Tank flange module

This combination of the bulkhead and filter element in the tank flange module guarantees a supply of urea/water mixture (AdBlue®) as follows:

- At an incline of 11° to 18°, a quantity of 220 g/h urea/water mixture (AdBlue®) for 30 min with at least 110 ml AdBlue®.
- At an incline of 45°, a quantity of 220 g/h urea/water mixture (AdBlue®) for 4 min with at least 20 ml AdBlue® .

It should be noted that the active tank must still have a remaining filling quantity of at least 2.5 l urea/water mixture (AdBlue®).

# B57 Engine

## 10. SCR 3

### Heating elements

The three electric auxiliary heaters (positive temperature coefficient) are located in the tank flange module, so that at minimum temperatures liquid urea/water mixture (AdBlue®) is available for the journey. The positive temperature coefficient elements can be regulated or switched off independently upon reaching a certain limit temperature. Intrinsic safety is thus guaranteed which prevents damage or destruction in the event of a fault with the continuous power supply.

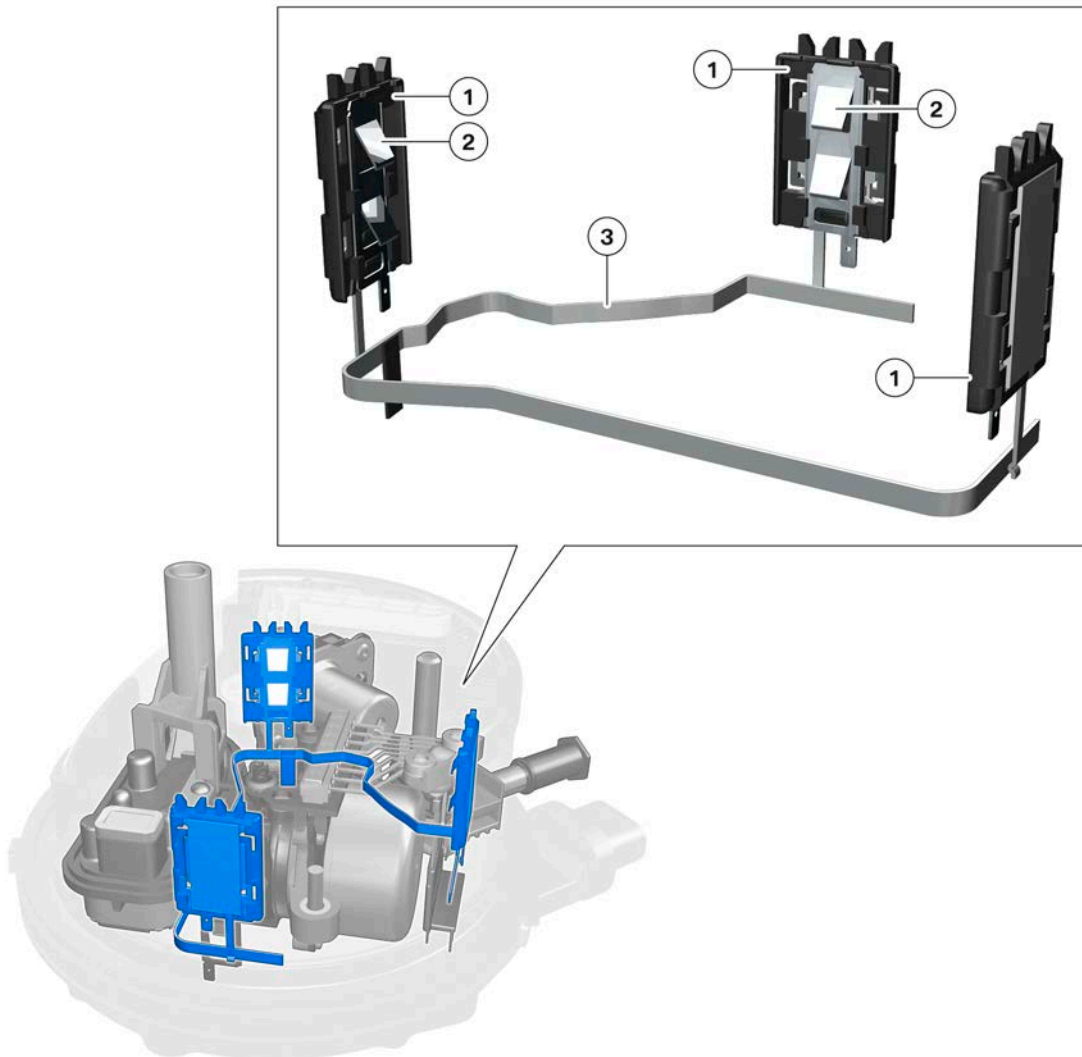

SCR 3, heating elements

TD16-0662

Index	Explanation
1	PTC heating element
2	Spring clips for mounting
3	Electrical ring connector

The heating element in the tank flange module is supplied with electricity by a power transistor. The SCR control unit controls the heating elements via the power transistor and therefore can also monitor their function.



# B57 Engine

## 10. SCR 3

### Pump

The pump is integrated in the tank flange module; it is secured by screws and located at the bottom of the active tank.

The pump works according to the orbital/eccentric principal and is driven by a three-phase brushless electric motor. The pump is therefore bidirectional; meaning it can be used to both, deliver and draw off, the urea/water mixture (AdBlue®).

A pressure accumulator on the output to the metering line exists downstream of the pump and prevents excessive pulsations in the metering line when the metering valve is open.

The pump is screwed on to the tank flange module at the bottom and can be accessed via the tank flange module's service cover.

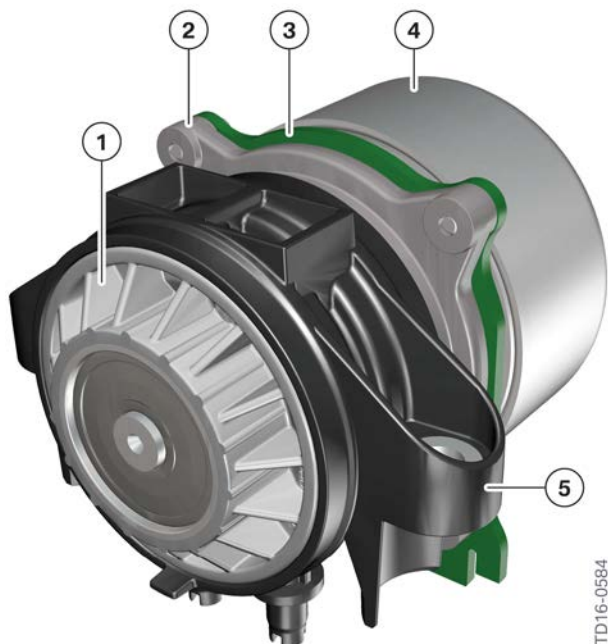

SCR 3, pump

Index	Explanation
1	Pump cap
2	Motor flange
3	Mounting bracket (Blank)
4	Motor
5	Pump body

Three hall sensors are installed in the pump motor for recording its position and speed. The sensors share the 5 V voltage supply with the pressure sensor/temperature sensor.

There is a shutoff valve upstream of the pump that closes when the pump is removed. This therefore prevents the urea/water mixture (AdBlue®) from escaping when replacing the pump.

# B57 Engine

## 10. SCR 3

### Pressure accumulator

To maintain the relative system pressure of 5.5 bar, the system is supported by a pressure accumulator in case of high urea/water mixture (AdBlue®) requirements. Furthermore, the pressure accumulator allows the pulsations to be dampened in the metering line when the metering valve is open.

An ice pressure damper integrated in the pressure accumulator housing protects the tank flange module components in case the urea/water mixture (AdBlue®) freezes.

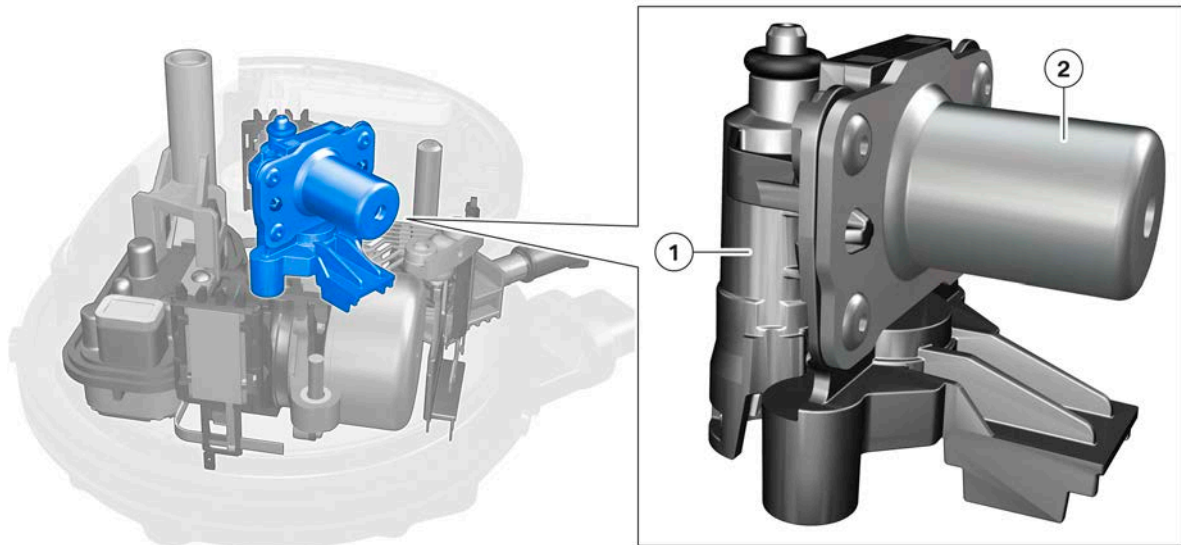

SCR 3, pressure accumulator

Index	Explanation
1	Housing with ice pressure damper
2	Pressure accumulator

# B57 Engine

## 10. SCR 3

### Pressure sensor/temperature sensor

SCR 3 uses a pressure sensor to determine and monitor the pressure of the system. A temperature sensor is also integrated in the pressure sensor and can be used to sense the temperature of the urea/water mixture (AdBlue®) in the tank flange module. The pressure sensor/temperature sensor signal is evaluated by the sensor unit and provided to the SCR control unit via a SENT protocol.

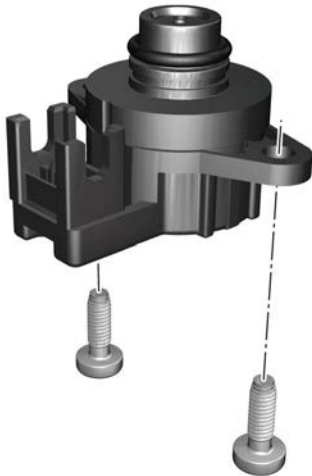

TD16-0585

SCR 3, pressure sensor

The pressure sensor/temperature sensor is screwed on to the bottom of the tank flange module and can be accessed via the tank flange module's service cover.

# B57 Engine

## 10. SCR 3

### Sensor unit

The temperature sensor is an NTC sensor (Negative Temperature Coefficient) and it delivers the signal for the control of the heating elements.

The level sensor in the tank flange module delivers the value of the level for the entire active tank. The filling level sensor is implemented as a direct piezo element and works according to the ultrasound principle.

The combined urea/water mixture (AdBlue®) quality sensor/filling level sensor is a combined piezo element and delivers the value for the urea/water mixture (AdBlue®) composition and also the filling level.

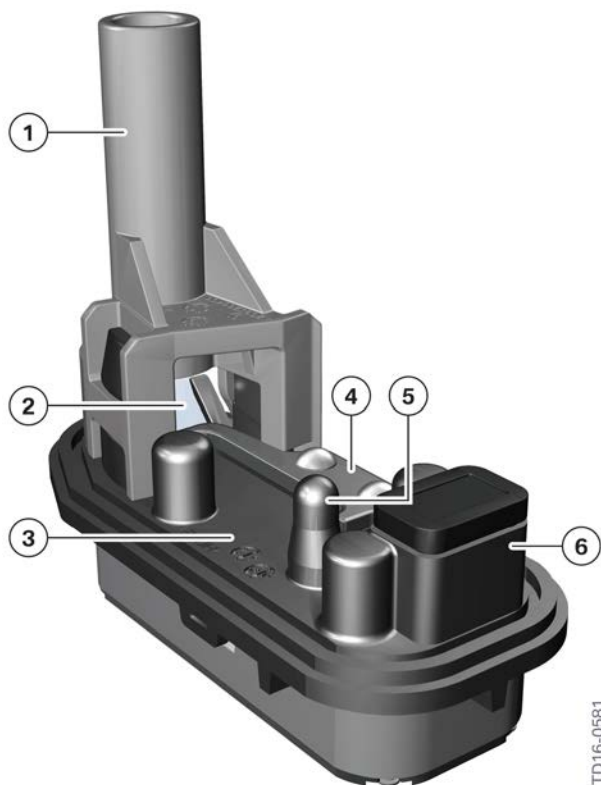

SCR 3, sensor unit

Index	Explanation
1	Measuring tube filling level
2	Passive reflector for determining the filling level
3	Direct piezo element/filling level sensor
4	Reflector plate for urea/water mixture (AdBlue®) quality
5	Temperature sensor
6	Combined piezo element (filling level/urea/water mixture (AdBlue®) quality)

# B57 Engine

## 10. SCR 3

### Metering line connection

The metering line connection includes a fine filter that prevents particles penetrating the tank flange module. This could be combustion residues which enter the tank flange module via the open metering valve when the urea/water mixture (AdBlue®) is pumped back.

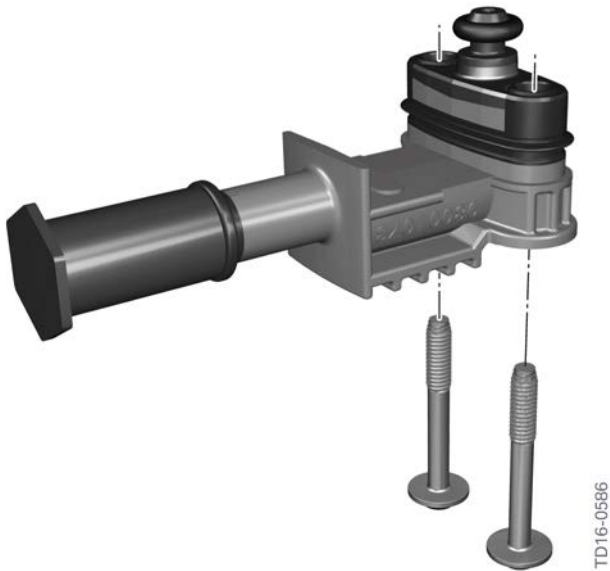

SCR 3, metering line connection

The metering line connection is screwed to the bottom of the tank flange module.

# B57 Engine

## 10. SCR 3

### 10.3.5. Heated metering line

Similar to the heating in the tank flange module for the active tank, the metering line is also electrically heated, when required, in order to prevent the urea/water mixture (AdBlue®) freezing.

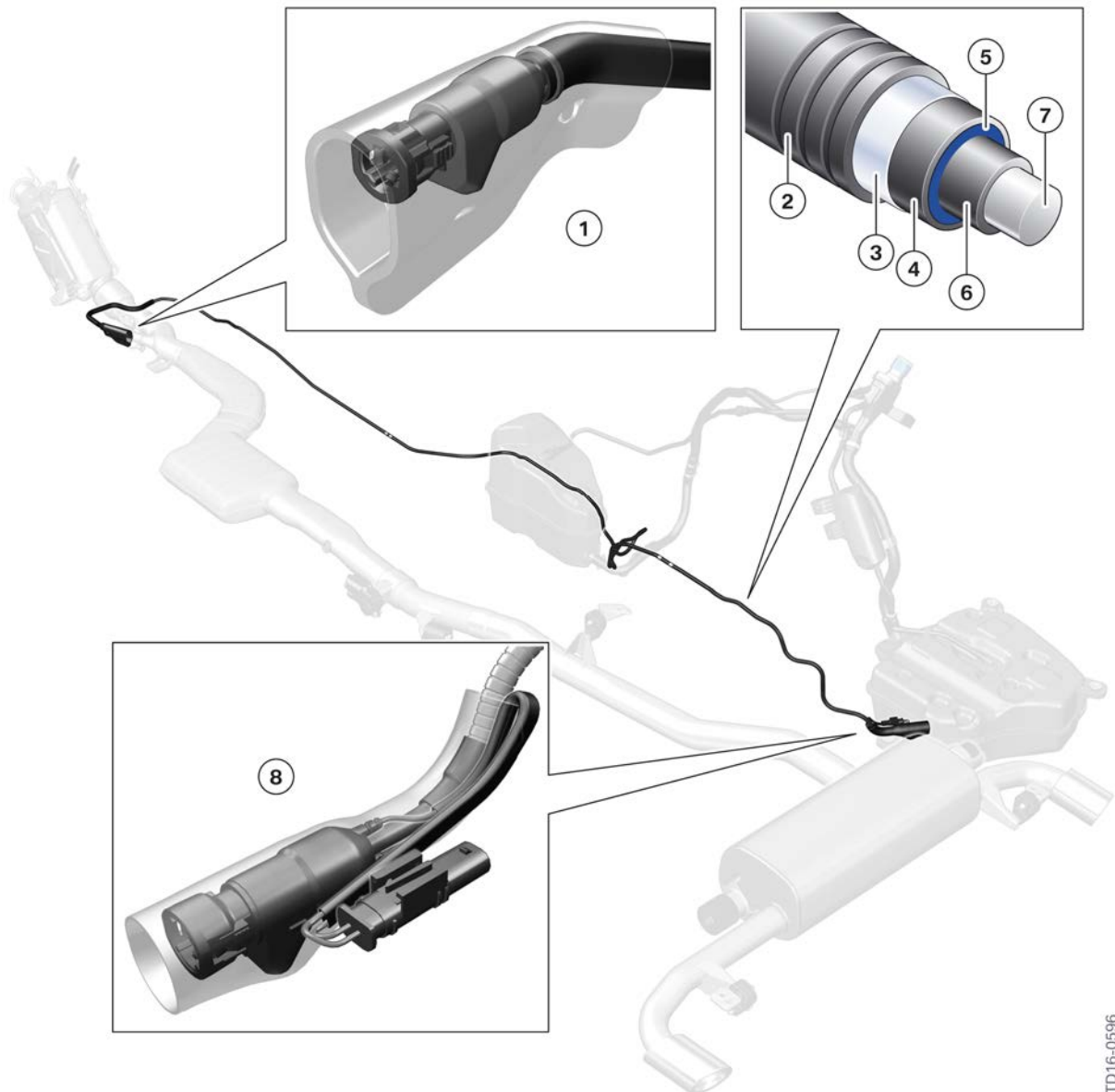

TD16-0596

SCR 3, metering line

Index	Explanation
1	Hydraulic connection for metering module
2	Protective sleeve
3	Insulator
4	Outer tube

# B57 Engine

## 10. SCR 3

---

Index	Explanation
5	Line, urea/water mixture (AdBlue®)
6	Inner pipe
7	Heating wire
8	Connection for tank flange module (hydraulic connection of metering line — electrical connection of metering line heating)

---

The inner pipe of the metering line is a 4 mm pipe that contains the heating wire. The 4 mm pipe is surrounded by a 6 mm outer pipe which delivers the urea/water mixture (AdBlue®). The wall thickness of the 6 mm outer pipe is 0.5 mm.

The heating element in the form of a ohmic heating wire is integrated inside the 4 mm pipe.

The metering line is thermally insulated in the 6 mm pipe by an insulator sleeve and then mechanically protected by a corrugated plastic coating.



---

**The metering line is connected to the metering line connection on the tank flange via the quick-release couplings. The metering line can only be unlocked if it is completely pushed into the metering line connection on the tank flange. Only then can the quick-release coupling be unlocked and pulled off the metering line connection on the tank flange.**

---

# B57 Engine

## 10. SCR 3

### 10.3.6. Metering module and mixer

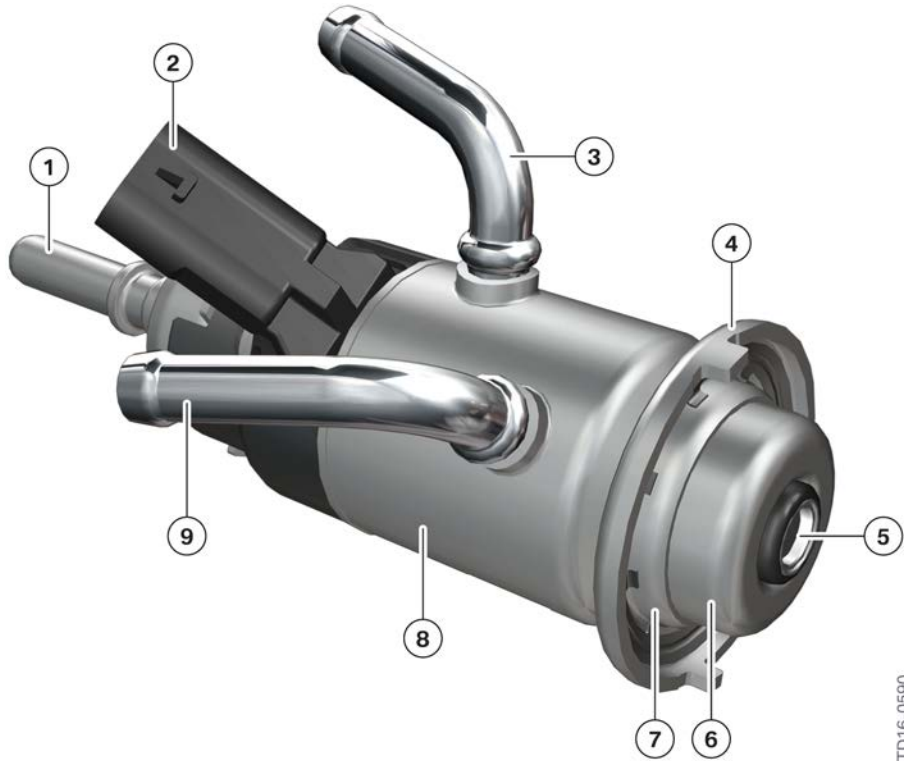

SCR 3, metering module

Index	Explanation
1	Metering line connection
2	Electrical connection, metering valve
3	Coolant inlet
4	Mounting flange
5	Metering port
6	Thermal protection
7	Sealing ring groove
8	Heat sink
9	Coolant return

The metering module ensures the injection of the urea/water mixture (AdBlue®) into the exhaust pipe. It includes a valve that is similar to the fluid injector of a gasoline engine with intake fuel injection.

The metering module is not electrically heated, but is heated up by the exhaust system, therefore it has to be cooled using coolant from the engine cooling system. The temperature of the metering module is monitored via a calculation module in the SCR control unit. The electrical resistance of the coil, which changes depending on the temperature, is used as an input variable for the calculation module. The SCR control unit determines the temperature of the metering module from this resistance value.



# B57 Engine

## 10. SCR 3

The metering module is activated by a pulse-width-modulated (PWM) signal from the SCR control unit in which the duty cycle determines the opening duration of the valve.

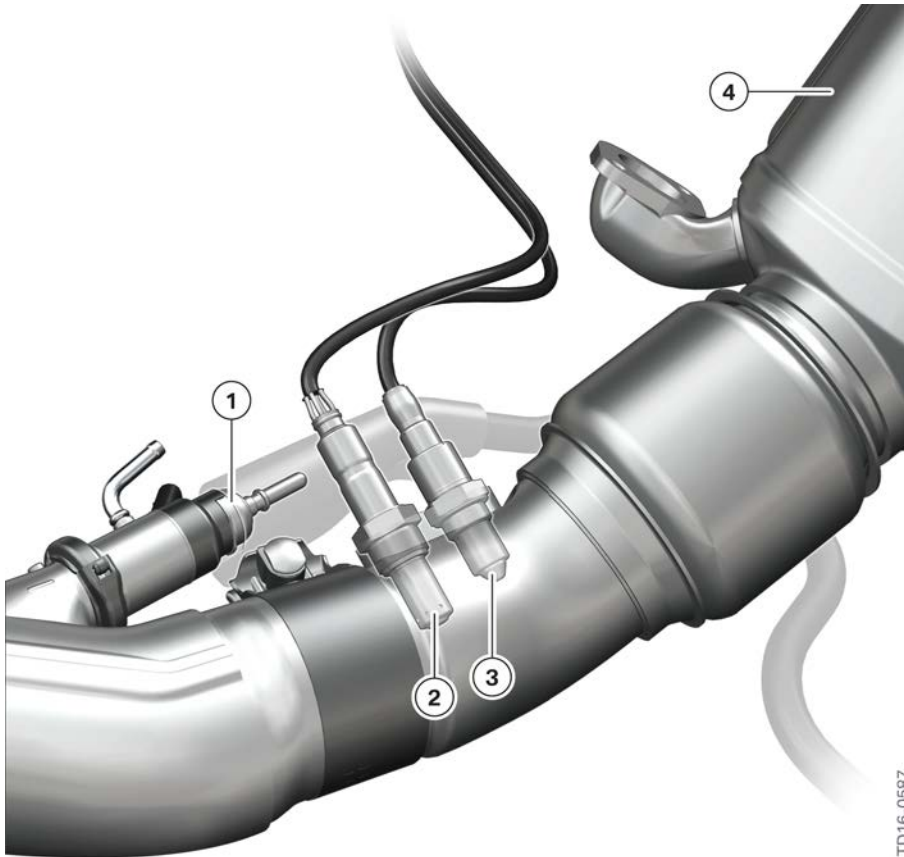

SCR 3, metering module installation location

Index	Explanation
1	Metering module
2	NO <sub>x</sub> sensor before the SCR catalytic converter
3	Oxygen sensor
4	Diesel particulate filter

A cone-shaped insert is attached at the metering module. This prevents the urea/water mixture (AdBlue®) drying up and clogging the metering valve injector. The cone shape creates a flow that prevents the urea/water mixture (AdBlue®) from sticking to the walls of the exhaust system. Deposits of urea on the insert are burnt off as it is heated by the exhaust flow. A clogged metering valve is detected by monitoring the pilot flow.

### Mixer

The mixer is located directly behind the metering module in the exhaust system. It swirls the exhaust flow in order to achieve a better mix of the urea/water mixture (AdBlue®) and the exhaust gas. This is necessary to ensure that the urea is fully transformed into ammonia.

# B57 Engine

## 10. SCR 3



SCR 3, mixer

Index	Explanation
1	Mixer

The mixer can be replaced separately in 6-cylinder engines. However in 4-cylinder engines, the mixer is part of the exhaust system and can only be replaced in conjunction with the corresponding component.

### 10.3.7. Urea/water mixture (AdBlue®) fluid filler cap

The urea/water mixture (AdBlue®) fluid filler cap includes a vent. This vent is necessary as both the filling of the SCR system and the tank ventilation are done via a combined fluid filler neck breather pipe and tank ventilation line.

The ventilation is achieved via a defined bore hole in the urea/water mixture (AdBlue®) fluid filler cap. Therefore, only fluid filler caps which are specific for the respective vehicle are used.

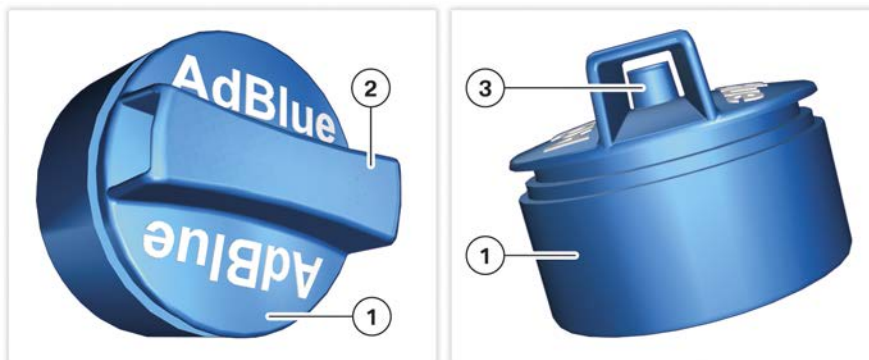

SCR 3, urea/water mixture (AdBlue®) fuel filler cap

Index	Explanation
1	Urea/water mixture (AdBlue®) fluid filler cap
2	Handle
3	Vent

# B57 Engine

## 10. SCR 3

A replacement or use of other fluid filler caps may cause a malfunction of the SCR system.

### 10.3.8. SCR control unit

The SCR control unit must ensure that the inlet sizes for the metering specification of the Digital Diesel Electronics (DDE) are in the allowable range. The fluid levels of the urea/water mixture (AdBlue®) passive tank (no vehicle operation without fluid), the medium temperatures in the urea/water mixture (AdBlue®) passive tank and the metering line (AdBlue®, freezing point at -11 °C / 12.2 °F) and the pressure build-up metering line (ensures fluid injection rate) are also taken into account here.

The SCR control unit ensures that all available information is also available for other applications, for example the fluid level indicator and the remaining range display in the Central Information Display (CID) (not for US).

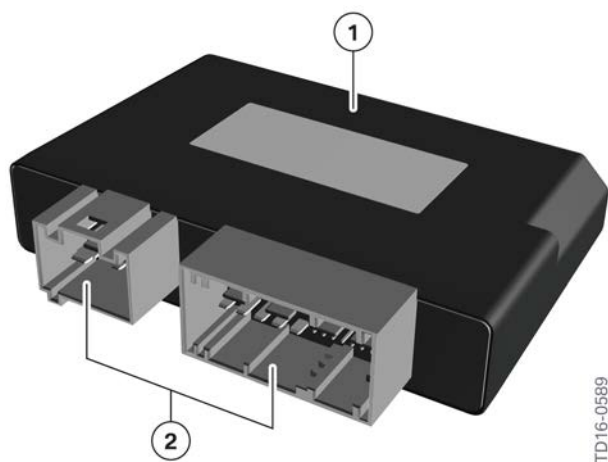

SCR 3, SCR control unit

Index	Explanation
1	Control unit
2	Connector strip

The correct and current installation locations of the SCR control unit can be found in the respective workshop systems (ISTA).

# B57 Engine

## 10. SCR 3

### 10.4. NO<sub>x</sub> sensors



SCR 3, NO<sub>x</sub> sensor

The nitrogen oxide sensor consists of a measuring probe and a corresponding control unit. The control unit communicates with the Digital Diesel Electronics (DDE) via the Local Controller Area Network.

The operation principle of a nitrogen oxide (NO<sub>x</sub>) sensor can be compared to a broadband O<sub>2</sub> sensor in that its function relies on an oxygen measurement to determine the nitrogen oxide content in an exhaust gas sample. The measuring procedure is based on the idea that the oxygen measurement relates directly to the nitrogen oxide measurement.

The following graphic illustrates the operating principle of this measurement procedure.

# B57 Engine

## 10. SCR 3

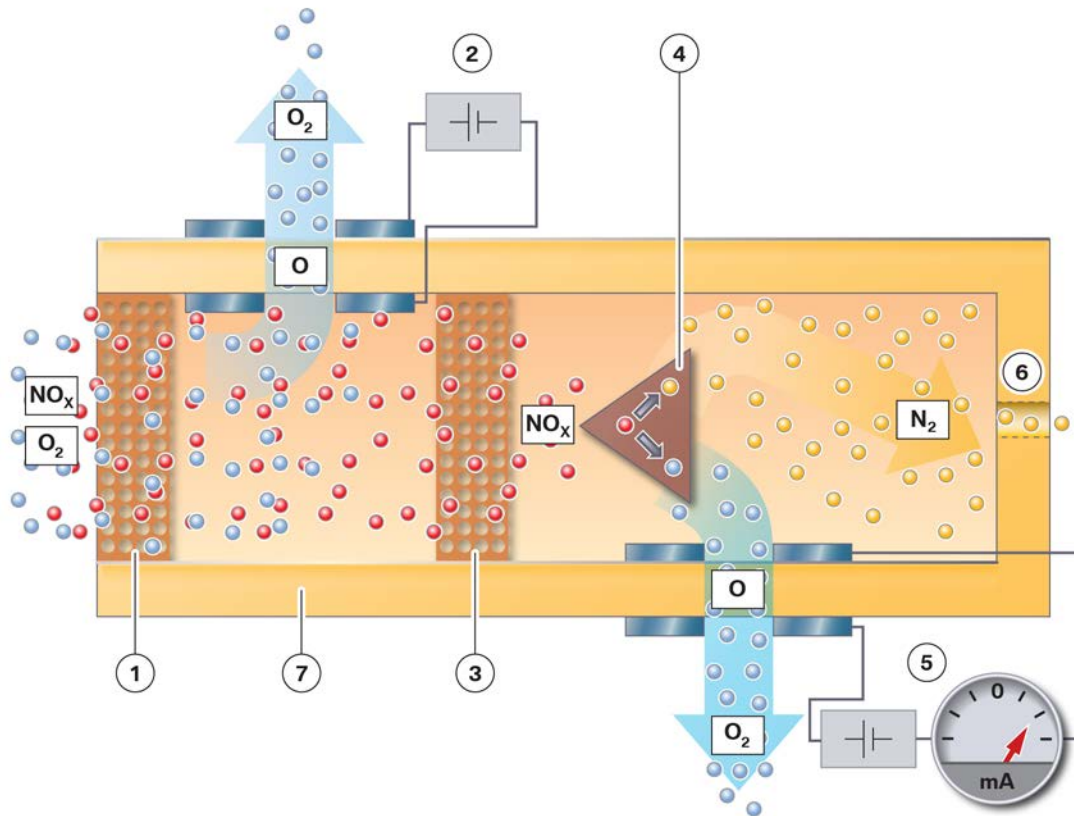

TD11-0239\_2

SCR 3, NO<sub>x</sub> sensor function

Index	Explanation
1	Barrier 1 (NO <sub>x</sub> and O <sub>2</sub> enter the sensor)
2	First chamber pump current (removes O <sub>2</sub> from the sample)
3	Barrier 2 (NO <sub>x</sub> enters the second chamber)
4	Catalytic element (decomposes NO <sub>x</sub> to N <sub>2</sub> and O <sub>2</sub> )
5	Second chamber pump current (the resulting O <sub>2</sub> is measured to determine N <sub>2</sub> )
6	Nitrate outlet (N <sub>2</sub> exits the sensor)
7	Solid electrolyte zirconium dioxide (ZrO <sub>2</sub> )

As the exhaust gas streams through the NO<sub>x</sub> sensor only O<sub>2</sub> and nitrogen oxide are of interest. In the first chamber the oxygen from the sample mixture is ionized with the help of the first measuring cell and extracted by solid electrolytes. Via the electromechanical pump current of the first chamber an oxygen sensor signal can be taken. At this point in the process the “free” oxygen (not bonded to nitrogen) is removed from the exhaust gas sample.

# B57 Engine

## 10. SCR 3

Then the remaining nitrogen oxide ( $\text{NO}_x$ ) goes through the second barrier and into the second chamber of the sensor. Here the  $\text{NO}_x$  is decomposed by a catalytic element into oxygen and nitrogen. The freed oxygen is then ionized as it passes through the solid electrolytes. The emerging pump current provides information on the quantity of the oxygen present in the sample. Based on this  $\text{O}_2$  quantity measurement, a conclusion can be made on the nitrogen content.



Bayerische Motorenwerke Aktiengesellschaft  
Händlerqualifizierung und Training  
Röntgenstraße 7  
85716 Unterschleißheim, Germany